



# INSTRUCTIONS

-J04572

REV. 2007-10-17

## BILLET NARROW BAND FOOTPEG KIT

### GENERAL

#### Kit Number

50911-08 (Black), 50978-99 (Chrome)

#### Models

For model fitment information, please see the P&A Retail Catalog or the Parts and Accessories section of [www.harley-davidson.com](http://www.harley-davidson.com) (English only).

#### Additional Parts Required

Separate purchase and installation of additional parts or accessories may be required for proper installation of this kit on your model motorcycle. Please see the P&A Retail Catalog or the Parts and Accessories section of [www.harley-davidson.com](http://www.harley-davidson.com) (English only) for a list of required parts or accessories for your model.

#### WARNING

The rider's safety depends upon the correct installation of this kit. Use the appropriate service manual procedures. If the procedure is not within your capabilities or you do not have the correct tools, have a Harley-Davidson dealer perform the installation. Improper installation of this kit could result in death or serious injury. (00333a)

#### NOTE

This instruction sheet references Service Manual information. A Service Manual for your model motorcycle is required for this installation and is available from a Harley-Davidson Dealer.

#### Kit Contents

See Figure 2 and Table 1.

Replacement Tread (Part Number 11306) is available from your local Harley-Davidson Dealer.

#### NOTE

Footpegs in kit 50911-08 are designed to show signs of wear. Over time the paint will wear off giving a distressed look.

### INSTALLATION

1. Remove the locknuts and screws that hold the existing footpegs in place. If your model motorcycle is equipped

with a pin and retaining ring, remove them and retain for future use. Save all hardware for installation of the new footpegs.

2. Remove the existing footpegs along with the spring washers. Save the spring washers for later installation.

#### NOTE

See Figure 1. When performing the next step, ensure that the spring washer is positioned inside of the footpeg support with the square edge (2) towards the inside of the support.

3. See Figure 1. Install the new footpegs in the same manner as the old footpegs were installed. Place a spring washer (1), along with the mount end of the footpeg, inside the slots (3) of the footpeg supports.

4. Secure each footpeg and spring washer with the screw and locknut or pin and retaining ring removed earlier. Tighten the locknuts to 19 ft-lbs (26 Nm).

#### WARNING

Footrests must fold up and toward rear of motorcycle if struck. Failure to set footrests to fold up and back could result in death or serious injury. (00366a)

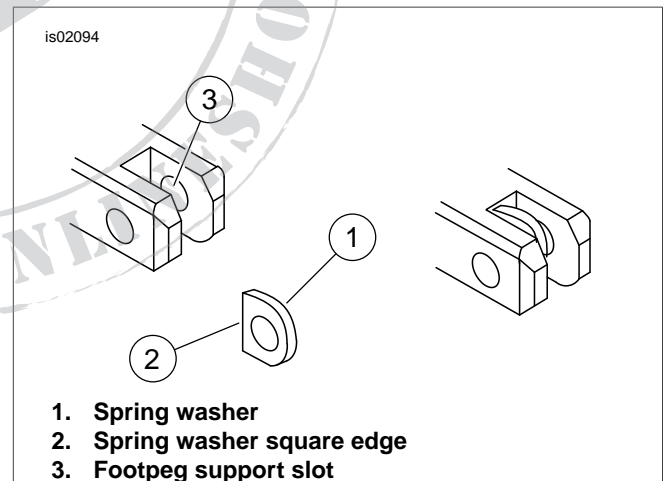
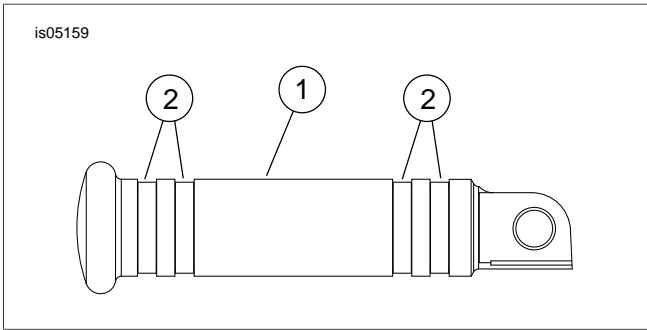

Figure 1. Footpeg Spring Washer Installation

## SERVICE PARTS

Table 1. Service Parts Table



Item	Description (Quantity)	Part Number
1	Billet footpeg assembly	Not Sold Separately
2	Footpeg rubber tread (4) (not shown)	11306

Figure 2. Service Parts: Footpeg Kit

