



# INSTRUCTIONS

-J03493

REV. 05-27-2005

Kit Number 49279-06

## DYNA PASSENGER FOOTBOARD SUPPORT KIT

### General

This kit is designed to fit 2006 and later Dyna model motorcycles.

### Additional Parts Required

This kit requires the separate purchase of passenger footboards. See the passenger footboard instruction sheet for information on attaching the footboards to the footboard supports. Contact a Harley-Davidson dealer for additional information.

### Installation

#### Prepare the Motorcycle

1. See Figure 1. On the left side of frame, remove the belt guard button head screw (1) and washer (2). Retain for future use.
2. Loosen the rear belt guard button head screw (3). Rotate belt guard (4) up and away from the front position.
3. Remove the belt guard mounting bracket screws (5) and belt guard mounting bracket (6). Discard screws and bracket.
4. If your model motorcycle is equipped with footpegs, remove both left and right footpegs.

5. If your model motorcycle is not equipped with passenger footpegs, remove the plastic inserts from the right side mounting holes.

#### Install Passenger Footboard Mounts

##### NOTE

This kit includes Pivot pins, Springs and Delrin balls for installation of passenger footboards to footboard supports. Some footboard kits may include these items. Retain Pivot pins, Springs and Delrin balls provided in this footboard support kit for possible use on the installation of footboards.

1. See Service Parts illustration. On the right side of motorcycle, install passenger footboard support (1) using two tapping screws (3). Tighten screws to 25 -35 ft-lbs (34 -47.7 Nm).
2. On the left side of motorcycle, install the left passenger support bracket (2) using two tapping screws (3). Tighten screws to 25 -35 ft-lbs (34 -47.7 Nm).
3. See Figure 1. Rotate belt guard (4) into position and install with original screw (1) and washer (2) saved in step 1 of preparation. Tighten screw to 10-15 ft-lbs (13.5 -20.3 Nm).
4. See Service Parts illustration. Install front belt guard screw into tapped hole (A) on left side passenger footboard support. Tighten screw to 10-15 ft-lbs (13.5 -20.3 Nm).

##### NOTE

Refer to footboard instructions for information on installing passenger footboards to footboard supports.

i07348

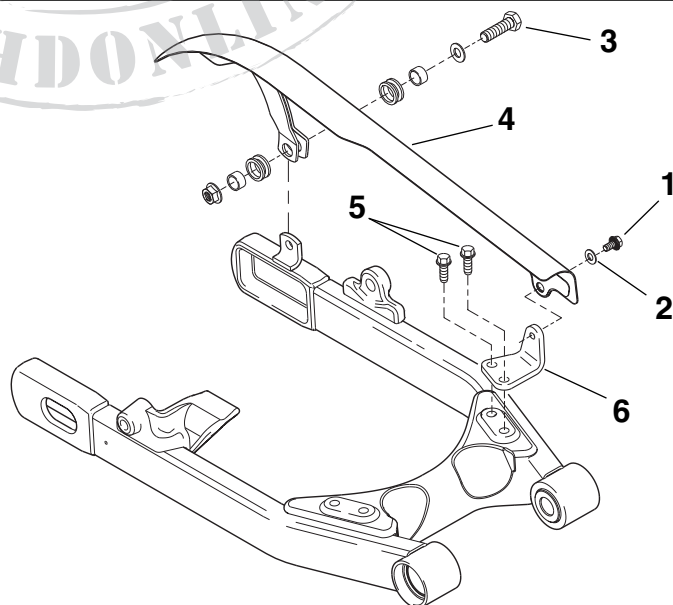

1. Belt guard button head screw
2. Washer
3. Rear belt guard button head screw
4. Belt guard
5. Belt guard mounting bracket screw (2)
6. Belt guard mounting bracket

Figure 1. Belt Guard Attachment Components



# Service Parts

Part No. 49279-06

Date 05/05

## Passenger Footboard Support Kit

i07331

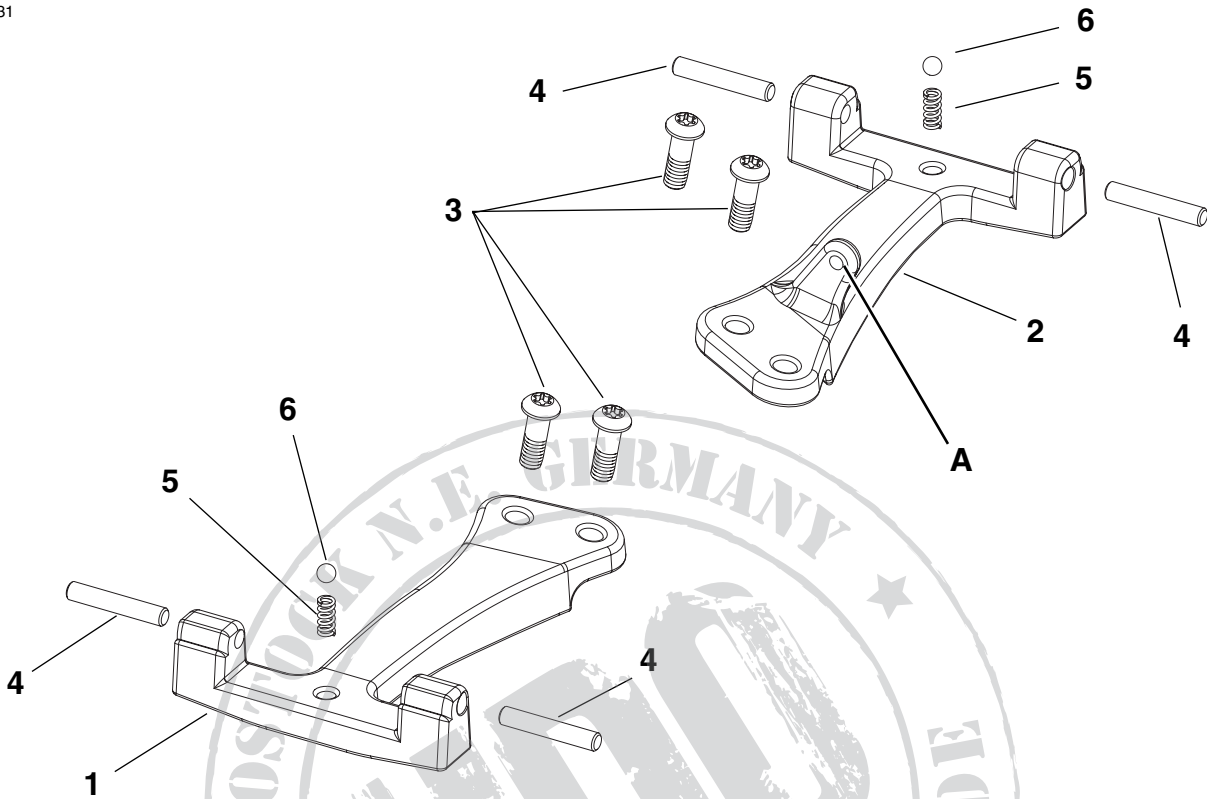

Item	Description	Part No.
1	Support, footboard, passenger, right	49280-06
2	Support, footboard, passenger, left	49281-06
3	Tapping screw (4)	4533
4	Pivot pin (4)	50933-86A
5	Spring (2)	33085-74
6	Delrin ball (2)	8861
A	Belt guard mounting hole	Reference only