



# INSTRUCTIONS

-J04379

REV. 2007-05-15

## BILLET SHIFTER PEG

### GENERAL

#### Kit Numbers

49238-98, 49254-99, 49256-99

#### Models

For model fitment information, please see the P&A Retail Catalog or the Parts and Accessories section of [www.harley-davidson.com](http://www.harley-davidson.com) (English only).

### Kit Contents

See Figure 1 and Table 1.

### INSTALLATION

1. Remove and discard the original equipment shifter peg. If needed, use a heat gun to apply heat to the shift lever and shifter peg threads to aid in peg removal.
2. See Figure 1. Insert the screw through the peg into the shift lever. Tighten the screw to 11-15 ft-lbs (15-20 Nm).



# SERVICE PARTS

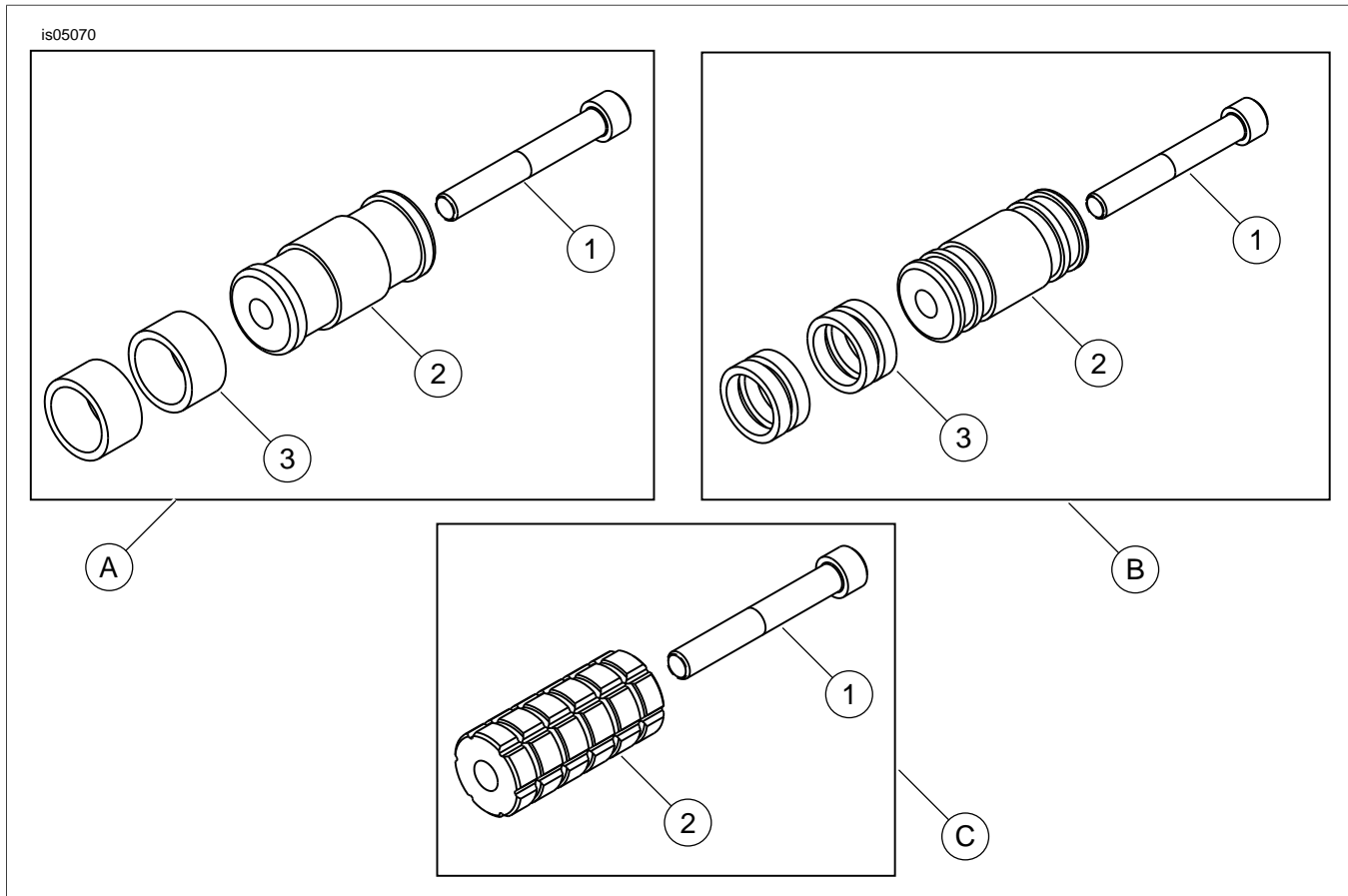

Figure 1. Service Parts: Billet Shifter Peg Kits

Table 1. Service Parts Table

| Item                    | Description (Quantity)                           | Part Number         |
|-------------------------|--|---------------------|
| <b>A - Kit 49256-99</b> |  |                     |
| 1                       | Screw, 5/16-24 x 2.25 socket head cap, lockpatch | 3396                |
| 2                       | Shifter peg                                      | Not Sold Separately |
| 3                       | Rubber (4)                                       | 11306               |
| <b>B - Kit 49254-99</b> |  |                     |
| 1                       | Screw, 5/16-24 x 2.25 socket head cap, lockpatch | 3396                |
| 2                       | Shifter peg                                      | Not Sold Separately |
| 3                       | Rubber (4)                                       | 11306               |
| <b>C - Kit 49238-98</b> |  |                     |
| 1                       | Screw, 5/16-24 x 2.25 socket head cap, lockpatch | 3396                |
| 2                       | Shifter peg                                      | Not Sold Separately |

