



# INSTRUCTIONS

-J02018

REV. 10-20-00

Kit Number 49087-01 and 49088-01

## REAR SADDLEBAG GUARDRAILS

### General

These kits are designed to fit all 1997 and later Touring bikes. Kit 49087-01 is designed to fit all 1997 and later FLHR/I, FLHRC/I, FLHT and FLTR/I models. FLHRC/I vehicles require the separate purchase of Reflectors, Part Nos. 59370-98 and 59371-98. Kit 49088-01 is designed to fit all 1997 and later FLHTC/I and FLHTCU/I models only.

See Service Parts illustrations for items contained in these kits.

### Installation

#### KIT NUMBER 49087-01

1. Remove and save fasteners that retain saddlebag guardrails.
2. Replace stock saddlebag guardrails with new guardrails from kit.
3. Screw in and torque each stock fastener as follows:
  - a. Four stock screws, Part No. 3678, using two new locknuts (1), Part No. 7667. Torque each screw to 19 ft-lbs.
  - b. Two stock screws, Part No. 3601 using two new locknuts (2), Part No. 7686. Torque each screw to 9 ft-lbs.

**For Domestic FLHRC/I Vehicles Only. (Does not apply to Harley Davidson International (HDI) vehicles):**

#### WARNING

Federal Motor Vehicle Safety Standard (FMVSS) 108 requires all motorcycles to be equipped with side reflectors. Install, or have Dealer install, the reflectors, Part Nos. 59370-98 and 59371-98, which are purchased separately. Loss of visibility to other motorists could result in death or serious injury.

1. See Service Parts illustration. Position reflector so it is centered on the vertical portion of the saddlebag guard 1" above the top end of the lower bend where the radius turns upward. Measure and use a small piece of tape to mark location for attachment of the lower edge of the reflector at the 1" mark.

2. Remove protective tape backing from one reflector. Locate reflector above the 1" mark. Apply reflector, using even pressure by rubbing back and forth on reflector. Repeat for other side.

#### Note

Reflectors are specific for each side. Reflectors have a flat end and a curved end. The curved end goes down. Top edge should be horizontal when positioned on guard. If not, reflector is for opposite side.

#### KIT NUMBER 49088-01

1. Remove and save fasteners that retain saddlebag guardrails.
2. Replace stock saddlebag guardrails with new guardrails from kit.
3. Using four hexsocket button head screws (4) removed earlier, attach saddlebag guards using the remaining two existing holes in each guardrail.
4. Screw in and torque each stock fastener as follows:
  - a. Four stock screws, Part No. 3678, using two new locknuts (1), Part No. 7667. Torque each screw to 19 ft-lbs.
  - b. Two stock screws, Part No. 3601 using two new locknuts (2), Part No. 7686. Torque each screw to 9 ft-lbs.



# Service Parts

Part No. 49807-01 and 49088-01 | Date 10/00

## Rear Saddlebag Guardrails

i03109.eps

**NOTE**  
Only right side of each saddlebag guard is shown

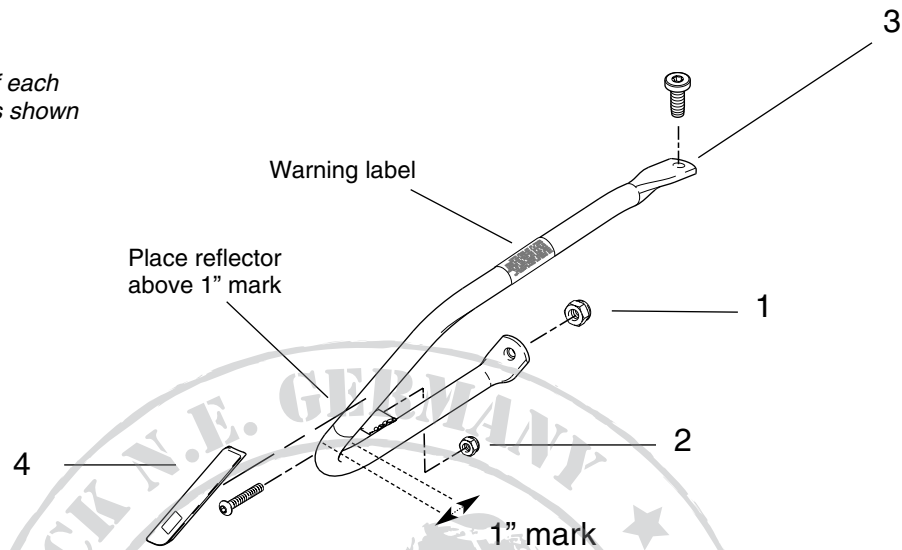

**Kit Number 49087-01**

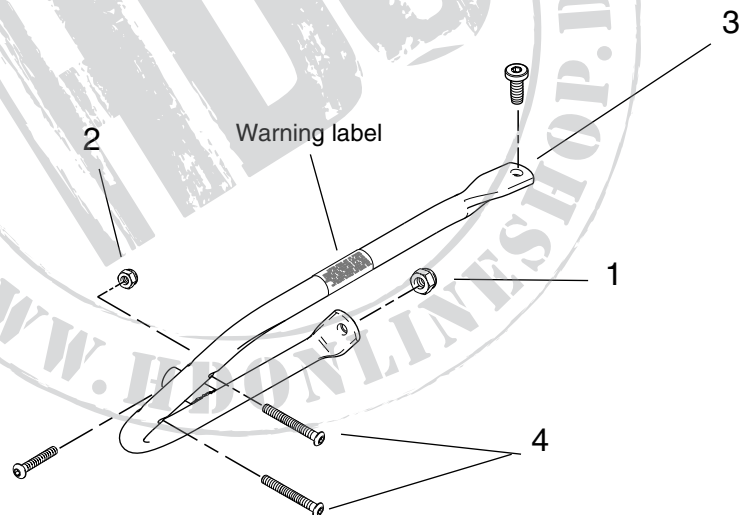

**Kit Number 49088-01**

### Kit Number 49087-01

Item	Description	Part No.
1	Lock nut (2)	7667
2	Lock nut (2)	7686
3	Guard assembly, rear (right) or Guard assembly rear (left) (Not shown)	49085-01 49082-01
4	Reflector, red (left)*	59370-98
5	Reflector, red (right)* (Not shown)	59371-01

(\*Items 4 and 5 for domestic FLHRC models only)

### Kit Number 49088-01

Item	Description	Part No.
1	Lock nut (2)	7667
2	Lock nut (2)	7686
3	Guard assembly, rear (right) or Guard assembly, rear (left) (Not shown)	49084-01 49081-01
4	Hex socket button (4)** (**Not included in kit)	3584

Note: Other parts shown not included in kits.