



INSTRUCTIONS

-J03509

REV. 2007-09-28

DYNA FORWARD CONTROL KIT

GENERAL

Kit Number

49080-06A

Models

For model fitment information, please see the P&A Retail Catalog or the Parts and Accessories section of www.harley-davidson.com (English only).

Additional Parts Required

Separate purchase of LOCTITE® 243 Threadlocker and Sealant - Blue (Harley-Davidson Part Number 99642-97) and Anti-Seize Lubricant (Harley-Davidson Part Number 98960-97) are required for proper installation of this kit. LOCTITE can be purchased from any Harley-Davidson Dealer.

NOTE

See Figure 4 and Figure 5. The mounting brackets and clevis (7, 18 and 21) may also be purchased separately to upgrade the standard FXDWG to this chrome kit.

WARNING

The rider's safety depends upon the correct installation of this kit. Use the appropriate service manual procedures. If the procedure is not within your capabilities or you do not have the correct tools, have a Harley-Davidson dealer perform the installation. Improper installation of this kit could result in death or serious injury. (00333a)

NOTE

This instruction sheet references Service Manual information. A Service Manual for your model motorcycle is required for this installation and is available from a Harley-Davidson Dealer.

Kit Contents

See Figure 4 and Table 1 and Figure 5 and Table 2.

INSTALLATION

Shifter Assembly

WARNING

To prevent accidental vehicle start-up, which could cause death or serious injury, disconnect negative (-) battery cable before proceeding. (00048a)

1. Disconnect battery cable, negative (-) cable first.
2. See Figure 4. Remove the left-side rider footrest assembly. Save the footrest and fasteners for installation. Discard the remaining hardware.
3. From the kit, press hole plugs (8) into the screw holes on the frame where the stock footrest assembly was mounted.

4. Remove plugs from forward control frame mount (I) and discard.
5. Remove the shifter lever (A) and left-hand shifter peg (D). Save for future use.
6. See Figure 2. Remove the primary chaincase cover (6) and primary chaincase housing (1). Refer to your model motorcycles Service Manual for removal procedures.

NOTE

See Figure 1. Before removing the gear shifter lever (1), it is necessary to mark the correct orientation of the lever. Using a marking tool, draw a location marking (4) on the end of the splined shaft (2) across from the casting split (3). This will allow the new gear shifter lever to be installed in the same orientation as the old lever.

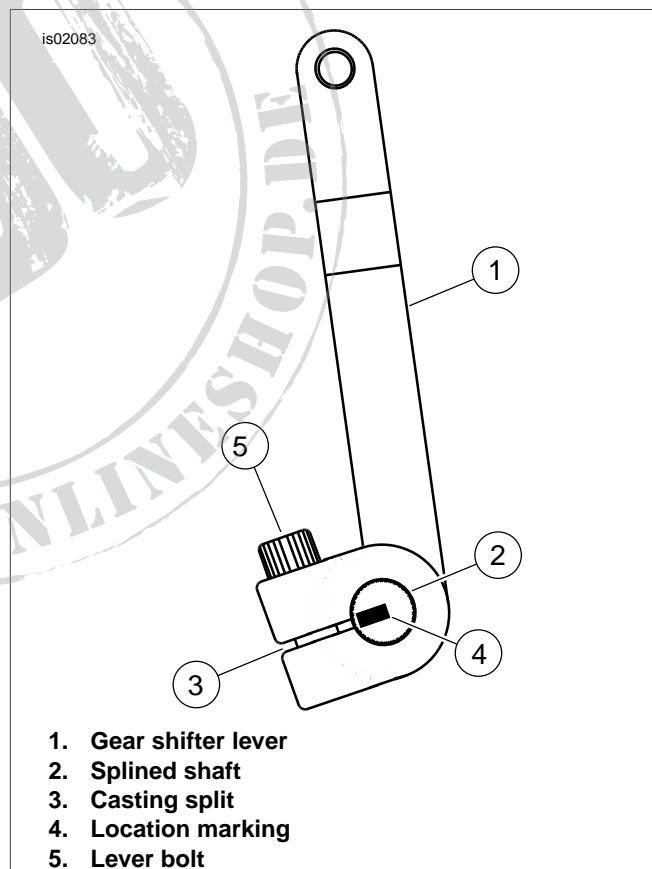

Figure 1. Gear Shifter Lever Orientation

7. After marking the gear shifter lever orientation, loosen the lever bolt (5) and remove the old lever. From the kit, install the new gear shifter lever onto the splined shaft in the same orientation as the old shifter lever.

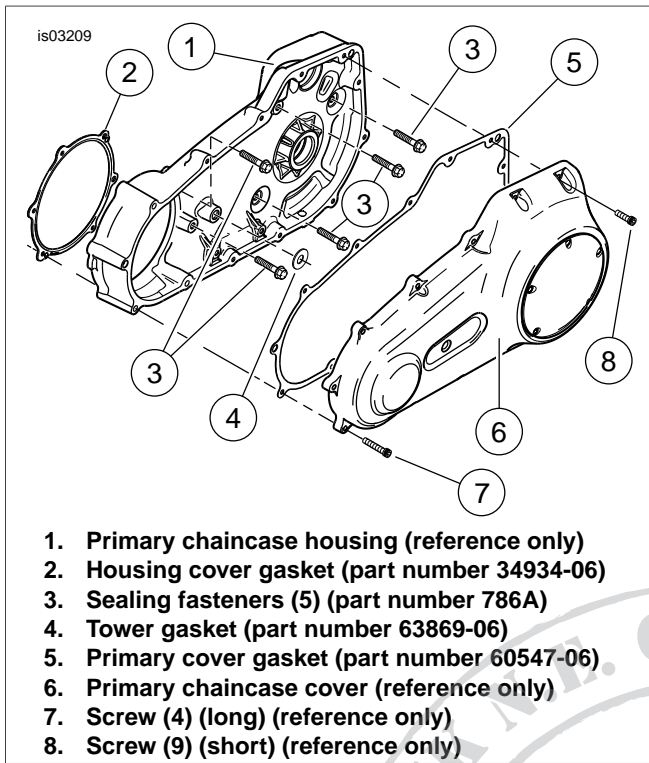

Figure 2. Primary Chaincase Cover and Housing Components

8. See Figure 4. Install a spring washer (5) on the shifter lever shaft (4). Coat the shaft with Loctite® Anti-Seize and slide the shaft into the shifter bracket (7). Install the shifter bracket onto the frame mounting holes using Torx® screws (10). Tighten the screws to 30-35 ft-lbs (41-47 Nm).
9. Install the shifter footpad onto the shifter bracket.
10. Install the **new** shifter rod (1) onto the transmission shifter lever (6) and shifter lever (4). Tighten to 70-90 **in-lbs** (8-10 Nm).

NOTE

After all shifter components are installed, move shifter through entire range of motion and check for interference with other components. Put primary chaincase housing in position and check for proper clearance with shifter linkage components.

11. See Figure 2. Using the gaskets and O-rings from the kit, install the primary chaincase housing (1) and primary chaincase cover (6). Refer to your model motorcycles Service Manual for installation procedures.

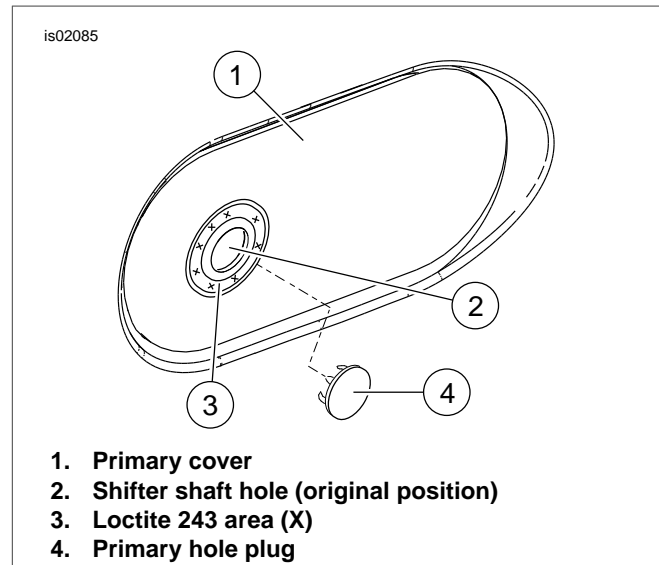

Figure 3. Outer Cover Plug Installation

12. See Figure 3. Clean the area around primary cover (2) hole, removing all dirt, oil and grease. Apply Loctite 243 (Harley-Davidson Part Number 99642-97) around opening (3). Insert primary hole plug (4) into opening. Remove any excess adhesive from surface. Allow Loctite to cure for 24 hours before operating vehicle.

Rear Brake Assembly

1. Remove the right-side rider footrest. Save the footrest and fasteners for installation.
2. See Figure 5. Loosen the brake rod jam nut (26) at the rear brake master cylinder.

NOTE

The master cylinder piston has flats for a wrench. Turn the flats on the piston to unscrew the brake rod from the master cylinder.

3. Unscrew the master cylinder piston from the stock brake rod.
4. Remove and discard the stock brake rod and brake pedal assembly.
5. Push hole plugs (8) into the screw holes on the frame where the stock brake pedal assembly was mounted.
6. Fasten the brake pedal bracket (18) to the frame with Torx screws (10). Tighten the screws to 30-35 ft-lbs (41-47 Nm).
7. Install the jamnut (26) all the way onto the new brake rod (25).
8. Fasten the brake rod to the master cylinder piston.
9. Install the brake rod (25) into the new brake pedal (16) using the clevis pin (24), washer (22) and cotter pin (20). Bend the legs of the cotter pin around the clevis pin shaft.
10. Coat the brake pedal pivot shaft (19) with Loctite Anti-Seize.
11. Fasten the brake pedal pivot shaft (19), brake pedal (16) and footrest mount clevis (21) to the brake pedal bracket (18) using the long Torx screw (23). Tighten the screw to 32-35 ft-lbs (44-47 Nm).

12. With a wrench on the master cylinder piston flats, turn the piston onto the brake rod until the brake pedal is elevated to an effective rider angle, and using at least half the threads available on the brake rod. Tighten the jam nut against the master cylinder piston.
13. Fasten the brake pedal pad (15) to the brake pedal (16) with the locknut (17). Tighten the nut to 50-80 in-lbs (6-9 Nm).
14. Fasten the stock footrest to the footrest mount clevis (21) using the stock fasteners from Step 1.

⚠ WARNING

Connect positive (+) battery cable first. If positive (+) cable should contact ground with negative (-) cable connected, the resulting sparks can cause a battery explosion, which could result in death or serious injury. (00068a)

15. Connect the battery cables, positive (+) cable first.

⚠ WARNING

After servicing brakes and before moving motorcycle, pump brakes to build brake system pressure. Insufficient pressure can adversely affect brake performance, which could result in death or serious injury. (00279a)

⚠ WARNING

Brakes are a critical safety component. Contact a Harley-Davidson dealer for brake repair or replacement. Improperly serviced brakes can adversely affect brake performance, which could result in death or serious injury. (00054a)

16. Test brakes for proper operation before riding vehicle.



SERVICE PARTS

is02086

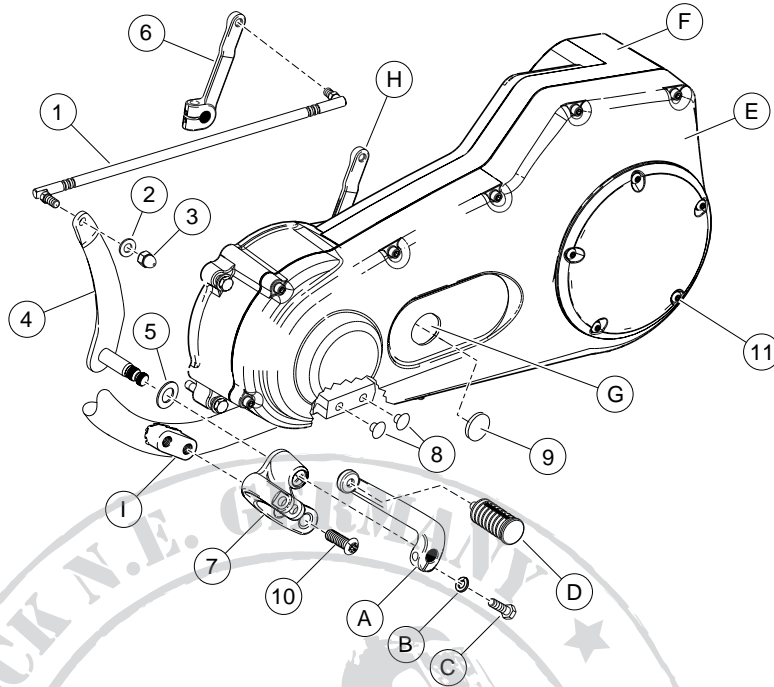

Figure 4. Service Parts: Dyna Forward Foot Control Kit

Table 1. Service Parts Table

Item	Description (Quantity)	Part Number
1	Shifter rod	34887-06
2	Washer, 5/16 x 11/16 x 1/16 inch	6702
3	Acorn nut, 5/16-18 locknut	7736
4	Shifter shaft and lever (new)	33789-06
5	Spring washer	34625-90
6	Transmission shifter lever	33883-06
7	Shifter bracket	33695-03
8	Hole plug (4)	740
9	Primary hole plug	90357-89
10	Torx screw, 3/16-18 x 1.0 inch (4)	4059
11	Sealing fasteners (5)	5-786A
Items mentioned in text, but not included in kit:		
A	Shifter lever	Reference only
B	Washer	Reference only
C	Bolt	Reference only
D	Footrest (left hand)	Reference only
E	Primary chaincase cover	Reference only
F	Primary chaincase housing	Reference only
G	Primary cover hole	Reference only
H	Gear shifter shaft and lever (old)	Reference only
I	Forward control frame mount	Reference only

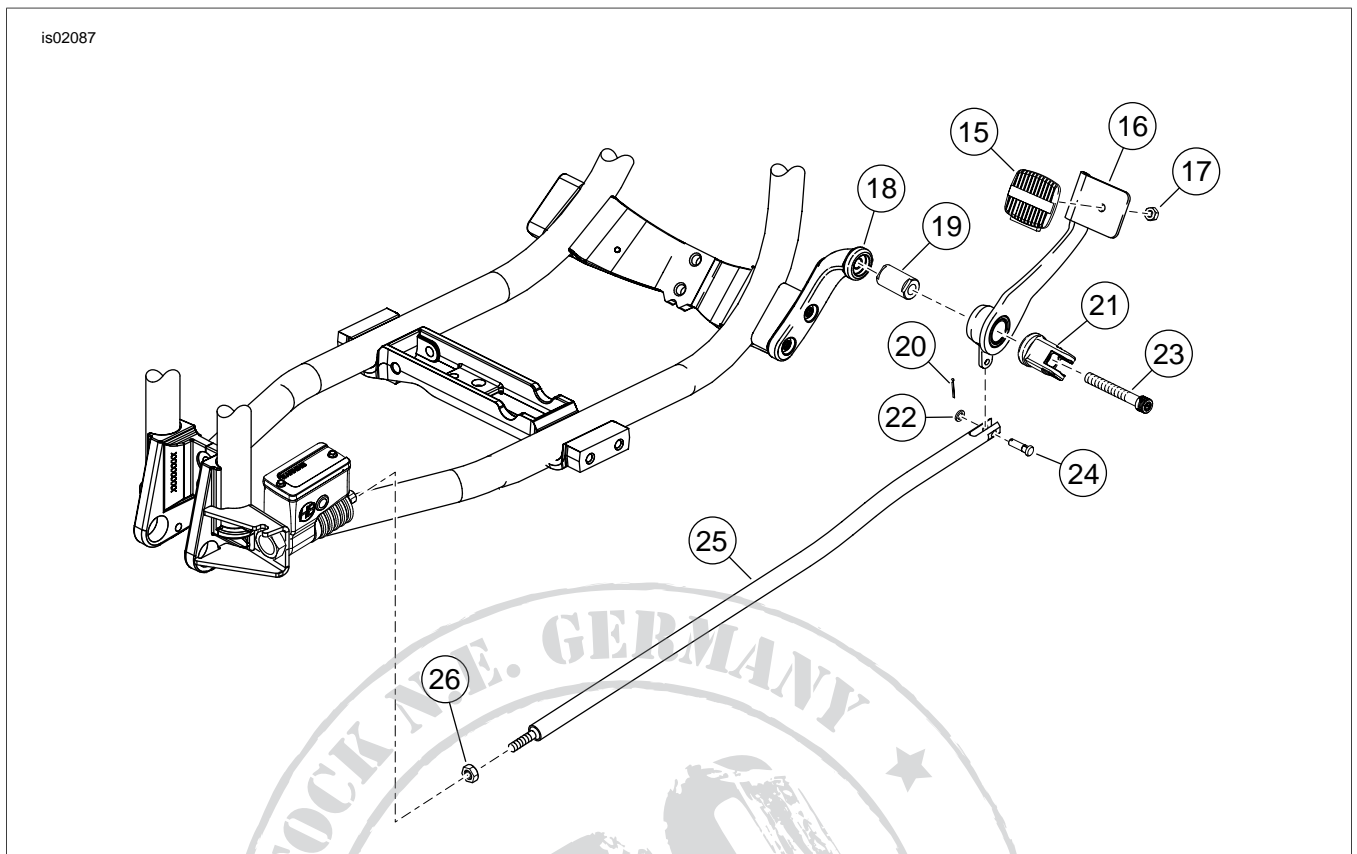

Figure 5. Service Parts: Dyna Forward Foot Controls Kit

Table 2. Service Parts Table

Item	Description (Quantity)	Part Number	Item	Description (Quantity)	Part Number
15	Brake pedal pad	42532-82	21	Footrest mount clevis	42664-03
16	Brake pedal	42542-03	22	Washer, 1/4 x 7/16 x 1/16 inch	6099
17	Locknut, 1/4-20	7742	23	Torx screw, 3/8-16 x 2-3/4 inch	4339A
18	Brake pedal bracket	33697-03A	24	Clevis pin	42460-80B
19	Brake pedal pivot shaft	42665-03	25	Brake rod	41955-03A
20	Cotter pin	515	26	Jamnut, 5/16-24	7744