



INSTRUCTIONS

-J07070

2015-08-24

EXHAUST GUARD

GENERAL

Kit Number

49000118

Models

For model fitment information, see the P&A retail catalog or the Parts and Accessories section of www.harley-davidson.com (English only).

Installation Requirements

▲ WARNING

The rider's safety depends upon the correct installation of this kit. Use the appropriate service manual procedures. If the procedure is not within your capabilities or you do not have the correct tools, have a Harley-Davidson dealer perform the installation. Improper installation of this kit could result in death or serious injury. (00333a)

NOTE

This instruction sheet refers to service manual information. A service manual for this year/model motorcycle is available from a Harley-Davidson dealer.

Kit Contents

See Figure 1. Only screws (Part No. 4873M) are sold separately.

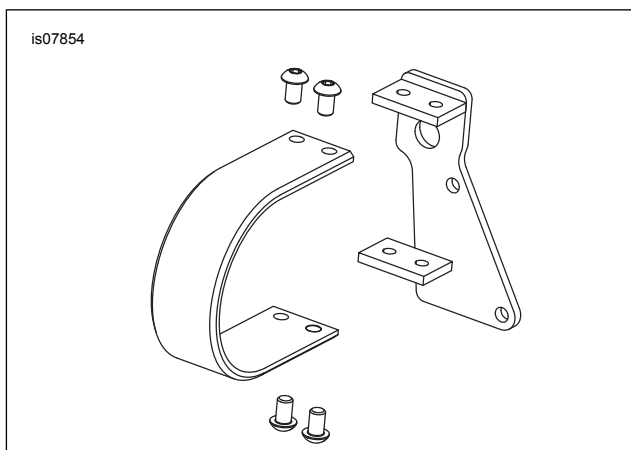

Figure 1. Muffler Guard Kit

PREPARATION

1. Remove the muffler. See the service manual.
2. See Figure 2. Remove two screws (2). Retain for assembly.

Installation

1. Disconnect brake switch connectors.

2. See Figure 4. Remove four screws (2) and hoop (3).
3. See Figure 3. Install bracket (1) using screws (2) removed earlier. Tighten to 25–30 N·m (18.4–22.1 ft-lbs).
4. Route the brake switch connectors through hole in bracket (1). Connect to brake switch.
5. Install the muffler. See the service manual.
6. See Figure 4. Apply LOCTITE 243 MEDIUM STRENGTH THREADLOCKER AND SEALANT (blue) to screws (2).
7. Install hoop (3) with four screws (2). Tighten to 29.8 N·m (22 ft-lbs)
8. Verify that muffler does not contact guard. Readjust muffler for clearance as necessary.

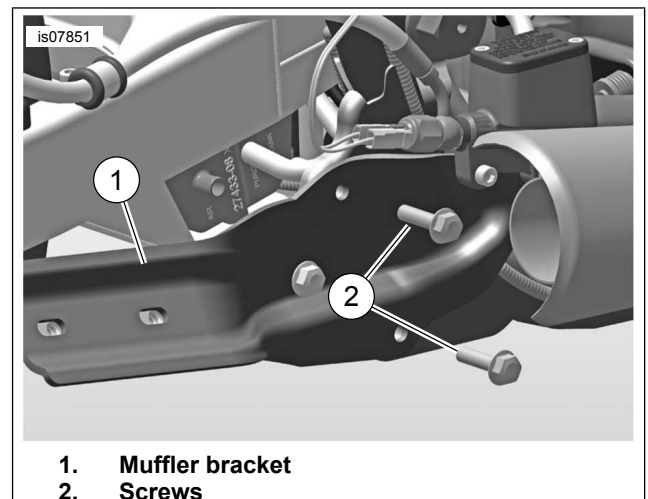

Figure 2. Remove Screws

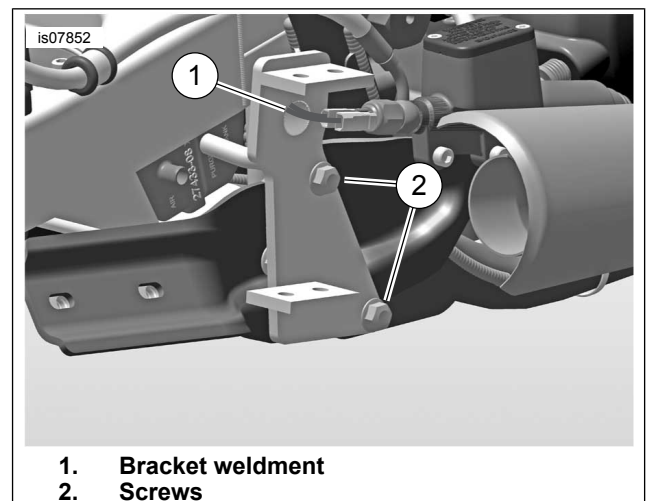

Figure 3. Install Bracket

-J07070

Many Harley-Davidson® Parts & Accessories are made of plastics and metals which can be recycled. Please dispose of materials responsibly.

1 / 2

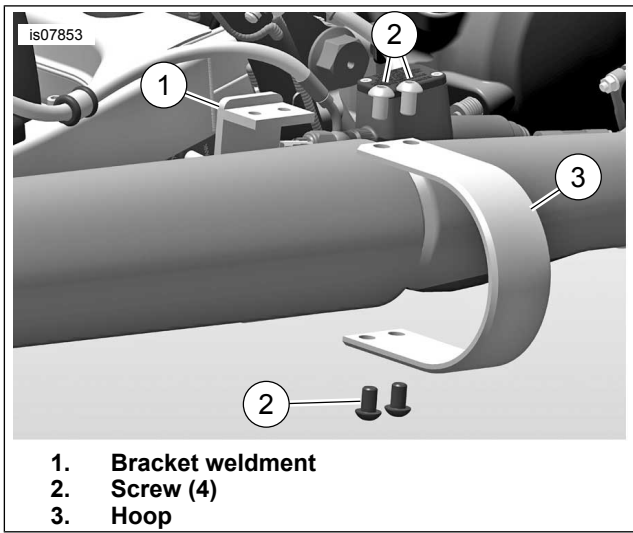

Figure 4. Install Guard