



# INSTRUCTIONS

-J05858

2015-10-21

## DYNA ENGINE GUARD KIT

### GENERAL

#### Kit Number

49000077, 49000078

#### Models

For model fitment information, see the P&A Retail Catalog or the Parts and Accessories section of [www.harley-davidson.com](http://www.harley-davidson.com) (English only).

### Installation Requirements

**Models with a center-mounted horn:** A horn bracket adapter kit is required. Refer to the latest P&A Retail Catalog for a list of required parts or accessories for your model.

#### ▲ WARNING

The rider's safety depends upon the correct installation of this kit. If the procedure is not within your capabilities or you do not have the correct tools, have a Harley-Davidson dealer perform the installation. Improper installation of this kit could result in death or serious injury. (00308a)

#### ▲ WARNING

Front and/or rear guard(s) can provide limited leg and cosmetic vehicle protection under unique circumstances. (Fall over while stopped, very slow speed slide.) It is not made or intended to provide protection from bodily injury in a collision with another vehicle or any other object. (00022b)

### INSTALLATION

1. See Figure 1. **Models with a center-mounted horn:** Install horn bracket adapter kit per instructions in that kit.

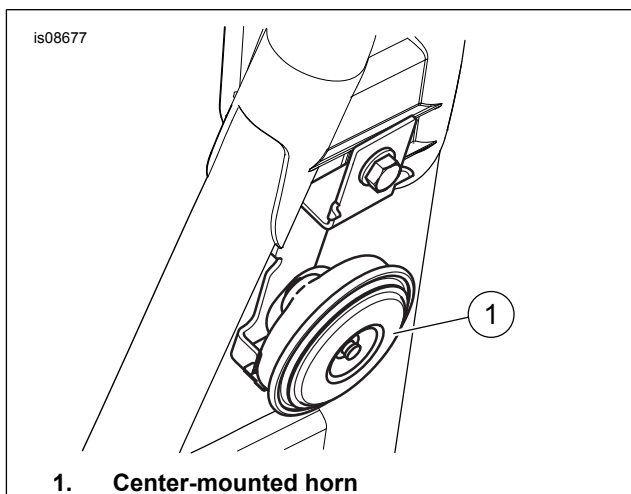

Figure 1. Center-Mounted Horn

2. Lift engine guard into place. Align top center mount of guard with frame crosspiece member between frame downtubes.
3. Secure top center mount to frame crosspiece member using 3/8-16 x 7/8 in bolt and lockwasher included in kit. Leave fasteners loose.

#### NOTE

The left U-bolt must be installed between the frame and the clutch cable. Do not pinch clutch cable between the U-bolt and the frame.

4. On right side of motorcycle, install U-bolt from kit around the frame member and into the holes in the lower mounting bracket. Secure loosely into place using two locknuts from kit.
5. On left side of motorcycle, install remaining U-bolt from kit around the left frame member and into holes in lower mounting bracket. Secure loosely into place using two locknuts from kit.
6. Tighten upper mounting bolt to 41–45 N·m (30–33 ft-lbs).
7. Alternately tighten U-bolt hardware to 34 N·m (25 ft-lbs). Tighten left and right side of the U-bolts evenly so that approximately the same length of bolt protrudes from end of nut.

### SERVICE PARTS

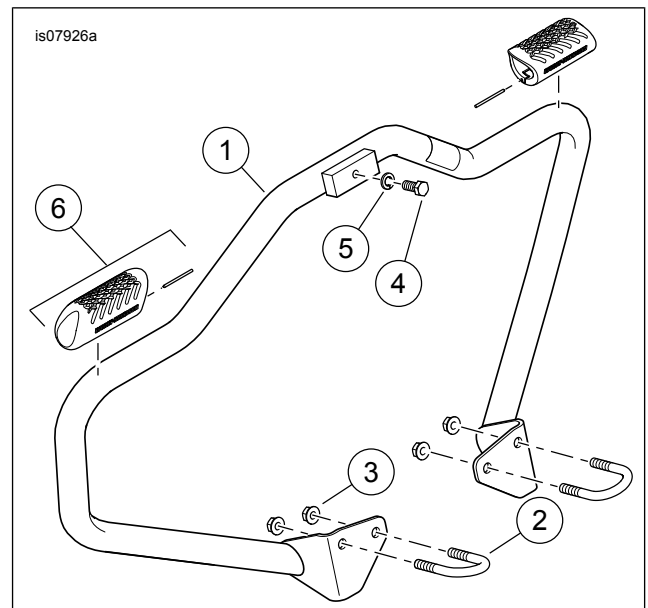

Figure 2. Service Parts: Dyna Engine Guard Kit

**Table 1. Service Parts Table**

<b>Item</b>	<b>Description (Quantity)</b>	<b>Part Number</b>
1	Engine guard	Not Sold Separately
2	U-bolt (2)	4794
3	Locknut, flange (4)	7601
4	Bolt, 3/8-16 x 7/8 inch	2851
5	Lockwasher, 3/8 inch	7038
6	Kit, footpad engine guard (2)	49000034