



INSTRUCTIONS

-J04978

REV. 2011-05-13

FRONT AGITATOR WHEELS

GENERAL

WARNING

Install only wheels and installation kits approved for your model motorcycle. Contact a Harley-Davidson dealer to verify fitment. Mismatching wheels and installation kits or installing wheels not approved for your model can cause loss of control, which could result in death or serious injury. (00610c)

Kit Numbers

40268-10, 47957-10, 55070-11, 55071-11, 43300115

Models

For model fitment information, see the P&A Retail Catalog or the Parts and Accessories section of www.harley-davidson.com (English only).

Kit Contents

See Figure 1 and the Service Parts Tables.

Additional Parts Required

Accessory hub caps are not compatible with this wheel.

This kit includes the custom wheel only.

Proper installation of this kit requires the separate purchase of the following parts which are available at a Harley-Davidson dealer:

- Wheel Installation Kit (See Table 2 and Table 3 to determine required installation kit.)
- 14 Brake Disc/Hub Cap Screws (3655A) or 3 Chrome screw kits (46646-05)
- Wheel Bearing Remover and Installer (94134-09)
- **For Kits 40268-10 and 47957-10:** Tire (44026-09A)
For Kits 55070-11 and 55071-11: Tire (55055-11)
- Right (41500008, 41500004 or 41500053) and left (41500007, 41500002 or 41500052) 7 point floating brake rotors

WARNING

The rider's safety depends upon the correct installation of this kit. Use the appropriate service manual procedures. If the procedure is not within your capabilities or you do not have the correct tools, have a Harley-Davidson dealer perform the installation. Improper installation of this kit could result in death or serious injury. (00333a)

NOTE

This instruction sheet references service manual information. A service manual for your model motorcycle is required for this installation and is available from a Harley-Davidson Dealer.

Recommended Additional Parts

The following Harley-Davidson Genuine Motor Accessories are recommended for proper maintenance and cleaning:

- Harley® Bright™ Chrome Cleaner (94683-99) (Not for use on kit 43300115)
- Harley® Glaze™ Polish and Sealant (99701-84)
- Harley® Wheel and Spoke Brush (43078-99)
- Harley-Davidson® Wheel and Tire Cleaner (94658-98)
- Harley® Preserve™ Bare Aluminum Protectant (99845-07)

INSTALLATION

NOTES

Use plastic protectors on tire mounting tools and rim clamps when mounting a tire to a painted wheel.

When mounting tires, liberally use tire lube on the wheel and tire.

For tire removal, use plastic inserts between the rim and tire after breaking the bead to create a large enough gap for the rim clamps to get into.

1. Remove existing front wheel assembly. Save axle, axle nut, brake disc and wheel spacers for kit installation. See the service manual.

NOTE

Install short valve stem (43157-83A) included in the installation kit. Discard all other valve stems.

2. See Figure 1. Install valve stem assembly (L) on wheel. See the service manual.

NOTICE

Do not re-use brake disc/rotor screws. Re-using these screws can result in torque loss and damage to brake components. (00319c)

NOTE

Do not install the bearing shim included in the installation kit.

3. Assemble wheel installation kit components and brake disc(s) to wheel, using the appropriate service parts table. See the service manual.
4. Install primary bearing with a Wheel Bearing Remover and Installer. See the service manual. The left side of the wheel

has DOT cast in the wheel to indicate the primary side of the wheel.

NOTE

Only install the required (separately purchased) tire.

If the wheel has a yellow dot sticker on the rim, orient the tire so the white dot is opposite of the sticker. If the wheel has a green dot sticker on the rim, orient the tire so the white dot is aligned with the sticker. If no rim dot sticker is present, see the service manual.

5. Install separately purchased tire (44026-09A or 55055-11). See the service manual.
6. Install wheel spacers (previously removed).

NOTE

Install wheel so that the valve stem is on the right side.

7. Install front wheel (1) and stock axle. See the service manual.

MAINTENANCE AND CLEANING

Chrome parts must be maintained regularly so they keep their original shine and luster.

1. Clean heavily-soiled wheel surfaces using Harley-Davidson Wheel and Tire Cleaner, applied with Harley Wheel and Spoke Brush.
2. Thoroughly clean chrome with a good quality chrome cleaner, such as Harley Bright Chrome Cleaner.
3. After cleaning and polishing, seal the finish with a good quality sealer, such as Harley Glaze Polish and Sealant.



SERVICE PARTS

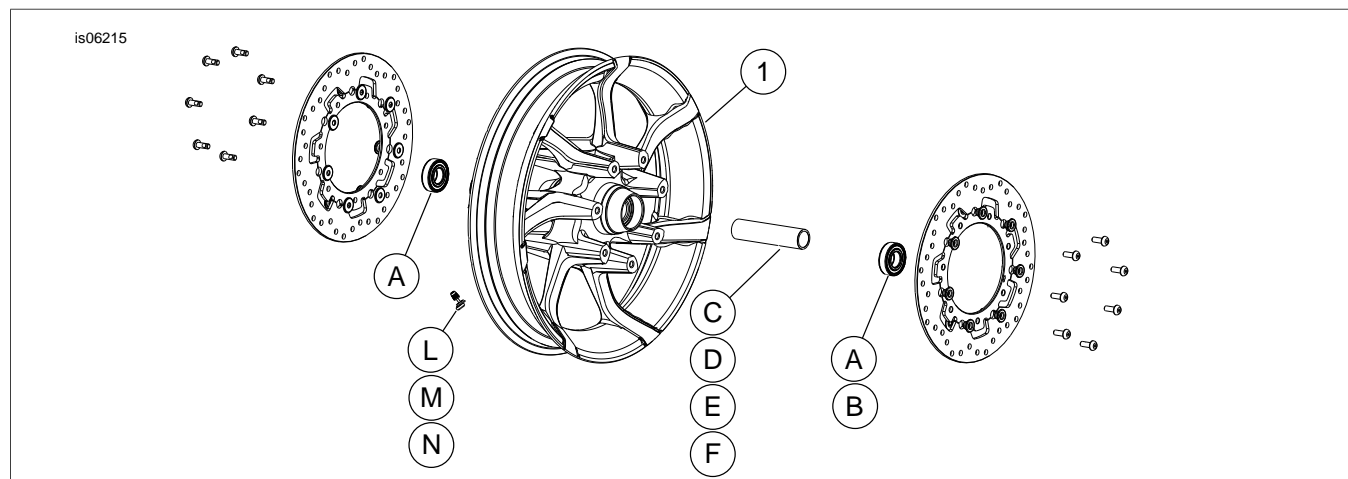

Figure 1. Service Parts: Front Agitator Wheels (19-inch shown)

Table 1. Service Parts and Wheel Kit Contents

Kit	Item	Description (Quantity)	Part Number
40268-10, 47957-10, 55070-11, 55071-11, 43300115	1	Wheel	Not Sold Separately

Table 2. FRONT 25 mm Bearing Wheel Installation Kit (41455-08C)

FRONT 25 mm Bearing Wheel Installation Kit (41455-08C)		ITEM (Quantity Used and Description)							
Fitment	Wheel Size	A	C	D	J	K	L	M	N
2008 Touring; 2009 and later FLHRC (non-ABS) and Trike (non-ABS)	16 x 3.0 in	2	0	1	0	1	*	*	*
2009 and later Touring (non-ABS)	17 x 3.0 in	2	0	1	0	0	*	*	*
2008 and later Touring (non-ABS)	18 x 3.5 in	2	0	1	0	**	*	*	*
2008 and later Dyna (except FXDWG and FXDF)	19 x 2.5 in	2	1	0	**	0	*	*	0
2008 and later VRSCAW, VRSCD, VRSCF and VRSCDX (non-ABS)	19 x 3.0 in	2	1	0	**	0	*	*	0
2009 and later Touring (non-ABS)	19 x 3.5 in	2	0	1	0	0	*	*	*
Installation kits are designed to work with many different wheel styles and fitments. Contact a Harley-Davidson dealer to verify that the wheel and installation kits are both designed and approved for the motorcycle they are being installed on.		A	Bearing, regular (2)				9276		
NOTES:		C	Axle sleeve				41748-08		
* See NOTE above valve installation step in INSTALLATION to determine which valve stem to use for your particular kit. Discard other valve stem(s).		D	Axle sleeve				41900-08		
** See NOTES for your wheel kit above the wheel assembly step in INSTALLATION to determine if bearing shim is used for your particular wheel kit and fitment.		J	Bearing shim***				41450-08		
*** Bearing shim installed under the primary bearing.		K	Bearing shim***				43903-08		
		L	Valve stem, short				43157-83A		
		M	Valve stem, long				43206-01		
		N	Valve stem, pull thru				40999-87		

Table 3. FRONT 25 mm Bearing ABS Wheel Installation Kit (41454-08B)

FRONT 25 mm Bearing ABS Wheel Installation Kit (41454-08B)		ITEM (Quantity Used and Description)									
Fitment	Wheel Size	A	B	C	D	J	K	L	M	N	
2008 Touring and 2009 and later FLHRC with ABS	16 x 3.0 in	1	1	0	1	0	1	*	*	0	
2009 and later Touring with ABS	17 x 3.0 in	1	1	0	1	0	0	*	*	*	
2008 and later Touring with ABS	18 x 3.5 in	1	1	0	1	**	**	*	*	*	
2008 and later VRSCAW, VRSCD, VRSCF and VRSCDX with ABS	19 x 3.0 in	1	1	1	0	**	**	*	*	0	
2009 and later Touring with ABS	19 x 3.5 in	1	1	0	1	0	0	*	*	*	
Installation kits are designed to work with many different wheel styles and fitments. Contact a Harley-Davidson dealer to verify that the wheel and installation kits are both designed and approved for the motorcycle they are being installed on. NOTES: * See <i>NOTE</i> above valve installation step in INSTALLATION to determine which valve stem to use for your particular kit. Discard other valve stem(s). ** See <i>NOTES</i> for your wheel kit above the wheel assembly step in INSTALLATION to determine which bearing shim to use for your particular wheel kit and fitment. *** Red side of bearing must be installed toward the wheel. The ABS bearing is primary. **** Bearing shim installed under the primary bearing.	A	Bearing, regular						9276			
	B	Bearing, ABS***						9252			
	C	Axle sleeve						41748-08			
	D	Axle sleeve						41900-08			
	J	Bearing shim****						41450-08			
	K	Bearing shim****						43903-08			
	L	Valve stem, short						43157-83A			
	M	Valve stem, long						43206-01			
N	Valve stem, pull thru						40999-87				

