



INSTRUCTIONS

-J03781

REV. 2006-05-05

FORK SLIDER DUST COVER KIT

GENERAL

Kit Number

46889-06

Models

This kit fits 2006 and later Dyna models. Will not fit with Screamin' Eagle Chrome Fork Brace Part Numbers 46634-06 or 46595-06.

Additional Parts Required

WARNING

The rider's safety depends upon the correct installation of this kit. Use the appropriate service manual procedures. If the procedure is not within your capabilities or you do not have the correct tools, have a Harley-Davidson dealer perform the installation. Improper installation of this kit could result in death or serious injury. (00333a)

NOTE

This instruction sheet references Service Manual information. A Service Manual for your model motorcycle is required for this installation and is available from a Harley-Davidson Dealer.

Kit Contents

See Figure 3 and Table 1.

REMOVAL

WARNING

To prevent accidental vehicle start-up, which could cause death or serious injury, remove maxi-fuse before proceeding. (00251a)

1. Refer to the Service Manual and follow the instructions given to remove the maxi-fuse.

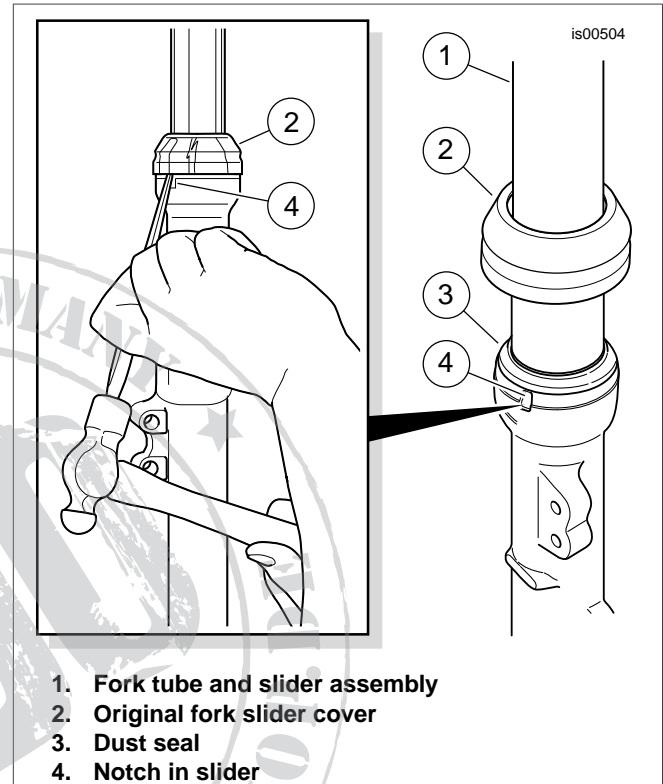

Figure 1. Fork Slider Cover Removal

NOTE

Be extremely careful not to scratch or mar the fork tubes. If a tube becomes scratched or marred, the fork dust seal (3) may leak and the fork tube will have to be replaced.

2. See FRONT FORK: REMOVAL in the Service Manual to remove the front fork tube and slider assemblies from the upper and lower triple clamps.
3. See Figure 1. Remove the original equipment fork slider cover (2) from one slider by inserting a brass drift into the notch (4) in the slider and lightly tapping the cover. Remove the cover.
4. Repeat for the remaining front fork tube and slider assembly, and original equipment fork slider cover.

is00505

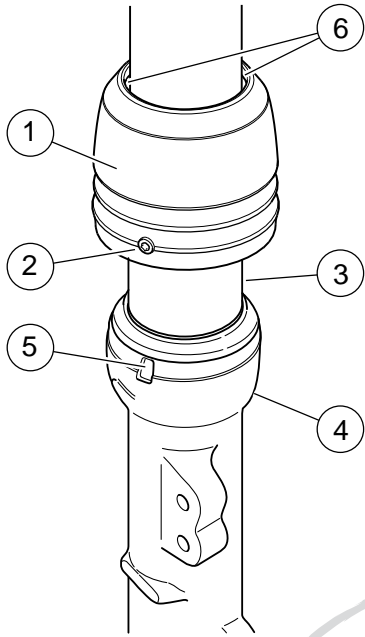

- 1. Decorative fork slider dust cover
- 2. Set screw
- 3. Fork slider tube
- 4. Fork slider
- 5. Notch in slider
- 6. Gap

Figure 2. Assemble New Dust Cover to Slider Tube

INSTALLATION

1. See Figure 2. Thread a set screw (2) partially into the threaded hole of a decorative fork slider cover (1) from the kit.
2. Slide the dust cover over the fork slider tube (3), aligning the set screw with the notch (5) in the slider (4). Slide the dust cover down until it makes full contact with the slider. Tighten the set screw.
3. Check for an even gap (6) between the dust cover and the fork tube.
4. Repeat for the remaining fork tube.
5. See FRONT FORK: INSTALLATION in the Service Manual to re-install the front fork tube and slider assemblies to the upper and lower triple clamps.
6. Refer to the Service Manual and follow the instructions given to re-install the maxi-fuse.

SERVICE PARTS

is00503

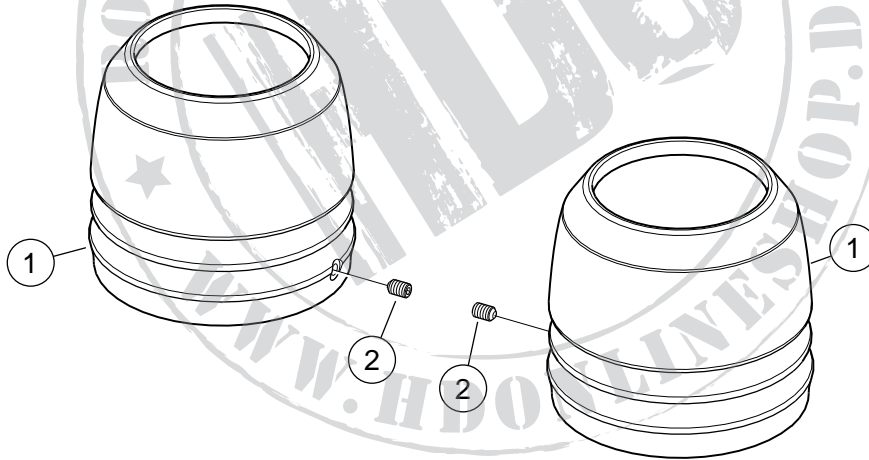

Figure 3. Service Parts, Fork Slider Dust Cover Kit

Table 1. Service Parts Table

Item	Description (Quantity)	Part Number
1	Decorative fork slider cover (2)	Not Sold Separately
2	Set screw, #8-32 x 1/4 in., with lock patch (2)	3321