



INSTRUCTIONS

-J02854

REV. 2006-05-22

CHROME FORK SLIDERS

GENERAL

Kit Number

46562-04

Models

For the most up-to-date model fitment information, please see product label or www.harley-davidson.com.

Additional Parts Required

WARNING

The rider's safety depends upon the correct installation of this kit. Use the appropriate service manual procedures. If the procedure is not within your capabilities or you do not have the correct tools, have a Harley-Davidson dealer perform the installation. Improper installation of this kit could result in death or serious injury. (00333a)

NOTE

This instruction sheet references Service Manual information. A Service Manual for your model motorcycle is required for this installation and is available from a Harley-Davidson Dealer. We recommend that this kit be installed by a factory-trained technician at your Harley-Davidson dealership. Improper installation of this kit could result in death or serious injury.

- Air impact wrench
- Torque wrench
- Fork spring compression tool
- Damper tube extension tool
- Fork Tube Holder HD-41177
- Front Fork Oil Level Gauge HD-59000-A
- Fork Seal and Bushing Tool HD-36583 (small dia.)
- Harley-Davidson Type E Fork Oil (HD-99884-80, 16 oz.).
- Loctite® 243 Threadlocker and Sealant - Blue (99642-97)
- Loctite® Anti-Seize Lubricant (98960-97)

Kit Contents

See Figure 2 and Table 1.

INSTALLATION

The fork sliders included in this kit install in the same manner as the original equipment parts. Refer to the Service Manual for proper installation procedures.

NOTE

Prior to installation of this kit, check the bores of the new chrome sliders to be certain they are free of dirt and debris or damage to the new sliders may occur.

1. Support the motorcycle so the front end is off the floor and the forks are fully extended.
2. Remove the front fender, front brake caliper(s), and front wheel according to instructions found in the Chassis section of the appropriate Service Manual.

NOTE

On some models other parts will also need to be removed to access the front forks. See the Service Manual.

3. Drain and remove the front forks. See the Chassis Section of the Service Manual.

WARNING

Wear safety glasses or goggles when servicing fork assembly. Do not remove slider tube caps without relieving spring preload or caps and springs can fly out, which could result in death or serious injury. (00297a)

4. Disassemble the front fork tubes according to instructions in the Service Manual, and replace the original fork sliders with the chrome sliders from the kit.
5. Assemble the front fork tubes, replacing worn seals, bushings or other additional items as needed.



1. Install bottom of reflector 2.0 inches above center of axle

Figure 1. Reflector Placement

NOTE

Do not use an impact wrench to tighten the drain screws. Use of an impact wrench may damage the screws.

6. Tighten the drain screws to 13-17 **in-lbs** (1.46-1.92 Nm).
7. Fill with TYPE E FORK OIL (Harley-Davidson Part Number 99884-80) according to the instructions found in the Service Manual.
8. Install the front fork and any parts that were removed to access the front forks. Install the front fender, wheel, and caliper(s) according to instructions found in the Chassis section of the Service Manual.

WARNING

Federal Motor Vehicle Safety Standard (FMVSS) 108 requires motorcycles to be equipped with rear and side reflectors. Be sure rear and side reflectors are properly mounted. Poor visibility of rider to other motorists can result in death or serious injury. (00336b)

NOTE

The front reflectors located on both sides of the fork sliders will be removed, cleaned and installed on the new chrome fork sliders.

9. See Figure 1. Using a piece of dental floss (or similar material) in a back and forth motion, loosen reflector from fork slider at both ends. Rotate reflector from side to side until it can be removed. Retain reflector for future use.

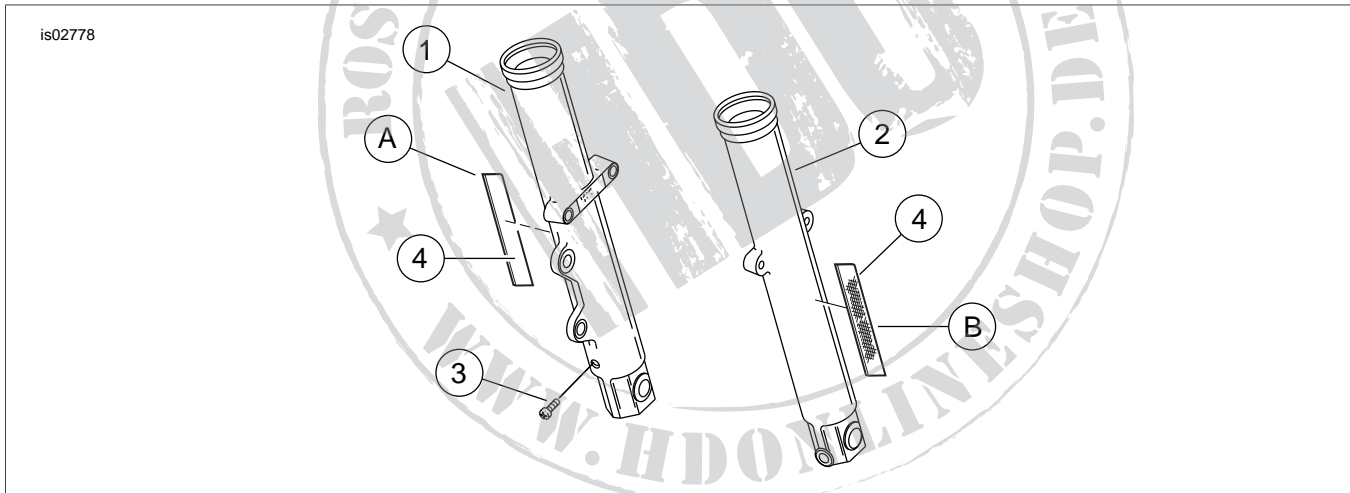

Figure 2. Service Parts: Chrome Fork Sliders

Table 1. Service Parts: Chrome Fork Sliders

Item	Description (Quantity)	Part Number
1	Fork slider, left side, (chrome)	46563-04
2	Fork slider, right side (chrome)	46564-04
3	Drain screw with washer (2)	45790-80
4	Tape, double sided foam (2)	53791-06
Items mentioned in text, but not included in kit:		
A	Reflector, left	59482-00
B	Reflector, right	59481-00

Repeat procedure on the opposite side fork slider.

10. Peel off any excess adhesive from both reflectors. Surface must be clean for reinstallation.
11. Peel off one side of backing on foam double sided tape. Press firmly on tape to secure it to reflector. Repeat double sided adhesive tape installation on remaining reflector.

NOTE

The bottom edge of reflector should be two inches (50 mm) above the center of the axle shaft.

12. See Figure 1. Remove second side (outside surface) of adhesive backing. Place reflector in position (1) and press reflector firmly into place to activate the adhesive. Repeat for remaining reflector.

WARNING

Whenever a wheel is installed and before moving the motorcycle, pump brakes to build brake system pressure. Insufficient pressure can adversely affect brake performance, which could result in death or serious injury. (00284a)

13. Pump brakes prior to test riding vehicle.
14. Test ride the vehicle to ensure proper fork travel and rebound.

SERVICE PARTS