



INSTRUCTIONS

-J02642

2007-11-29

BLACK REAR DRESSER BAR KIT

GENERAL

Kit Number

46548-03

Models

For model fitment information, please see the P&A Retail Catalog or the Parts and Accessories section of www.harley-davidson.com (English only).

Additional Parts Required

These kits fit 2004 and later FLTR/I and FLHRS/I motorcycles. However, the existing stock lower saddlebag supports must be removed and replaced with the following parts:

Left lower saddlebag support part number 49194-85

Right lower saddlebag support part number 90781-93

⚠ WARNING

The rider's safety depends upon the correct installation of this kit. Use the appropriate service manual procedures. If the procedure is not within your capabilities or you do not have the correct tools, have a Harley-Davidson dealer perform the installation. Improper installation of this kit could result in death or serious injury. (00333a)

NOTE

This instruction sheet references Service Manual information. A Service Manual for your model motorcycle is required for this installation and is available from a Harley-Davidson Dealer.

Kit Contents

See Figure 2 and Table 1.

INSTALLATION

1. Remove the seat from the motorcycle. Refer to the SEAT section of the appropriate Service Manual.
2. Refer to the Service Manual to remove the saddlebags.
3. See Figure 1. Gently pull one side cover (1) from the frame downtubes (no tools are required).
4. **2004 and later FLTR/I and FLHRS/I:** Support the upper muffler with a block of wood. Remove and save the two 5/16-18 x 1/2 inch long hex head capscrews and washers that secure the muffler with the lower saddlebag support rail.

5. Remove and save the two 5/16-18 x 1 inch long pan head screws (7) and locknuts (8) that hold the lower saddlebag support to the rear fender support bracket. Using a T-40 TORX drive head, remove and save the 3/8-16 screw (9) and 3/8-16 locknut (10) fastening the front flange to the horizontal frame tube. Remove and save the rubber mount (not shown) from the lower saddlebag support. Remove and discard the lower saddlebag support (4).
6. Repeat Steps 3 through 5 for the opposite side.

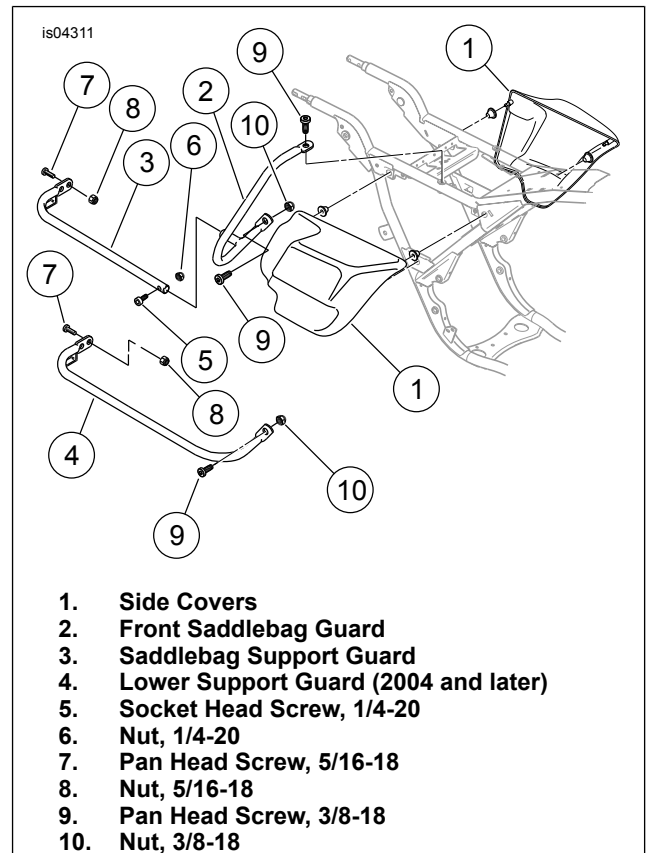

Figure 1. Saddlebag Support Removal

7. Using a T-40 TORX[®] drive head, remove and save the 3/8-16 screw (9) fastening the upper flange of the front guard to the horizontal upper frame. Remove and save the 3/8-16 screw (9) and 3/8-16 nut (10) from the lower flange of the guard to the frame. Remove and discard the saddlebag guard (2).
8. Repeat Steps 3 through 5 for the opposite side.

9. **2004 and later FLTR/I and FLHRS/I Installation:** Obtain either the left or right lower saddlebag support purchased separately. Reassemble, but don't tighten the two 5/16-18 x 1 inch long pan head screws (7) and locknuts (8) that hold the lower saddlebag support to the rear fender support bracket. Slide in the rubber mount and align the holes over the muffler. Secure the support to the muffler using the two 5/16-18 x 1/2 inch long hex head capscrews and washers removed in step 5 and tighten loosely.
10. Take the left or right black rear saddlebag side guard from the kit and place in position matching the holes in the vehicle frame. The new front side guards are side specific. Lift the lower support bar and insert the tube end into the receptacle on the black rear saddlebag side guard. Obtain a 1/4-20 x 1-1/4 hex socket screw and 1/4-20 locknut from the kit. Align the holes and insert the 1/4-20 x 1-1/4 screw through the tubes and loosely thread on the 1/4-20 locknut.
11. Using a T-40 TORX drive head, thread in a 3/8-16 screw (saved earlier) through the top flange of the new side guard and into the horizontal frame tube. Do not tighten.
12. Insert the 3/8-16 screw through the lower flange and frame tube and thread a 3/8-16 locknut (saved earlier) onto the screw. Do not tighten at this time.
13. Tighten the upper 3/8-16 screw (9) then the lower 3/8-16 screw (9) and 3/8-16 locknut (10) to 20.3–27.1 N·m (15–20 ft-lbs). Tighten the 1/4-20 screws (5) to 7.9–11.3 N·m (70–100 **in-lbs**).
14. Tighten the 5/16-18 screws (7) and the 5/16-18 locknuts (8) to 20.3–27.1 N·m (15–20 ft-lbs). Tighten the two screws that secure the muffler to the lower saddlebag supports to 20.3–27.1 N·m (15–20 ft-lbs).
15. Repeat steps 10 through 15 for the opposite side.
16. **All except 2004 FLTR/I and FLHRS/I:** Repeat Steps 11 through 14.
17. **Model FLHRCI only:** Peel off the backing and install the reflectors (4 or 5) in the same position as on the original guards.
18. Align the barbed studs in the side cover with the grommets in the frame downtubes and push firmly into place (no tools are required).
19. Refer to the Service Manual and install the saddlebags.
20. Refer to the Service Manual, and follow instructions to install the seat.

▲ WARNING

After installing seat, pull upward on seat to be sure it is locked in position. While riding, a loose seat can shift causing loss of control, which could result in death or serious injury. (00070b)

SERVICE PARTS

is04312

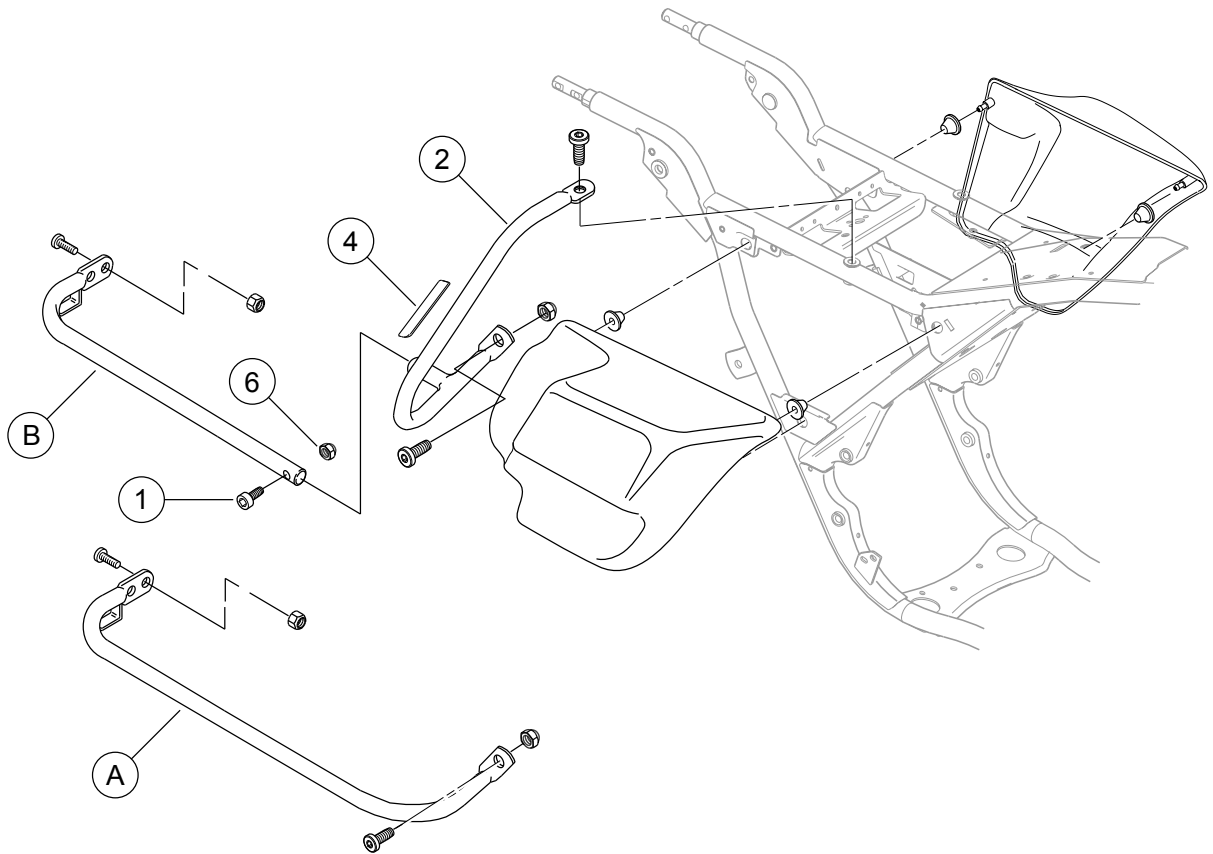

Figure 2. Service Parts: Rear Saddlebag Guard Kit (Black)

Table 1. Service Parts Table

Item	Description (Quantity)	Part Number
1	Screw, socket head cap 1/4-20 x 1-1/4 inch (2)	3601
2	Dresser bar, right side, rear, black	46557-03
3	Dresser bar, left side, rear, black	46556-03
4	Reflector, red, right side	59370-98
5	Reflector, red, left side	59371-98
6	Nut, hex lock	7686
Items mentioned in text, but not included in kit:		
A	Lower saddlebag guard	
B	Lower saddlebag support	