



INSTRUCTIONS

-J04432

REV. 2007-05-21

CHROME REAR MASTER CYLINDER COVER KIT

GENERAL

Kit Number

46463-08

Models

For model fitment information, please see the P&A Retail Catalog or the Parts and Accessories section of www.harley-davidson.com (English only).

Kit Contents

See Figure 1 and Table 1.

INSTALLATION

CAUTION

Do NOT allow dirt or debris to enter the master cylinder reservoir. Dirt or debris in the reservoir can cause improper operation and equipment damage. (00205b)

CAUTION

D.O.T. 4 brake fluid will damage painted and body panel surfaces it comes in contact with. Always use caution and protect surfaces from spills whenever brake work is performed. Failure to comply can result in cosmetic damage. (00239b)

1. Clean rear master cylinder cover, then loosen the two screws that hold cover in place.
2. Remove original cover and gasket.
3. Put new cover and gasket in position.

NOTE

The cover is labeled for DOT 4 BRAKE FLUID. Install this cover on reservoirs filled only with DOT 4 BRAKE FLUID. Do not mix

grades of brake fluid, as they are not compatible and could cause equipment damage.

CAUTION

Direct contact of D.O.T. 4 brake fluid with eyes can cause irritation. Avoid eye contact. In case of eye contact flush with large amounts of water and get medical attention. Swallowing large amounts of D.O.T. 4 brake fluid can cause digestive discomfort. If swallowed, obtain medical attention. Use in well ventilated area. KEEP OUT OF REACH OF CHILDREN. (00240a)

4. If necessary, add DOT 4 HYDRAULIC BRAKE FLUID to the master cylinder reservoir until the fluid level reaches the MAX marking (a ridge in the casting) inside the reservoir (A). Do not reuse old brake fluid. Use only DOT 4 fluid from a sealed container.

WARNING

Be sure the master cylinder relief port is not plugged. A plugged relief port can cause brake drag or lockup and loss of vehicle control, which could result in death or serious injury. (00317a)

5. Verify proper operation of the master cylinder relief port. Actuate the brake pedal. A slight spurt of fluid will break the fluid surface in the reservoir compartment if all internal components are working properly.

NOTE

Before installing the master cylinder cover, verify that the cover gasket bellows is not expanded. If the bellows is expanded, brake fluid will be ejected from the reservoir during cover installation, which could damage the vehicle finish.

6. Install cover screws and tighten screws (1) to 12-15 in-lbs (1.3-1.7 Nm).

SERVICE PARTS

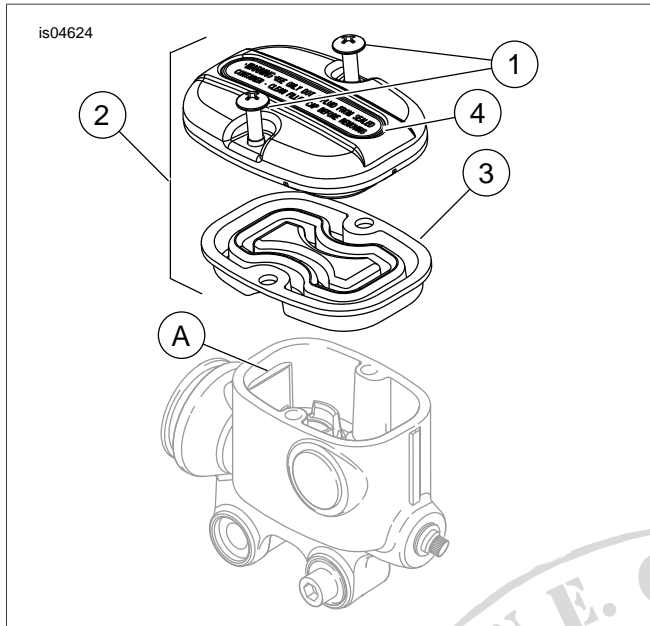

Figure 1. Service Parts: Chrome Rear Master Cylinder Cover Kit

Table 1. Service Parts: Chrome Rear Master Cylinder Cover Kit

Item	Description (Quantity)	Part Number
1	Screws (2)	42882-06
2	Cover, reservoir assembly	Not Sold Separately
3	Gasket	11902
4	Decal, reservoir cover	42856-06
Items mentioned in text, but not included in kit:		
A	DOT 4 hydraulic brake fluid MAX marking (ridge in the casting)	

