



INSTRUCTIONS

-J02173

REV. 09-10-2003

Kit Numbers 46301-01, 46303-01 and 46305-01

SHIFTER LINKAGE COVER

General

These kits fit 1999 and later Touring model motorcycles equipped with stock shifter linkage.

Kit 46301-01 is a "Diamond" pattern cover.

Kit 46303-01 is a "Harley-Davidson script"-style cover.

Kit 46305-01 is an "engraved Harley-Davidson medallion"-style cover.

NOTE

A Service Manual for your model motorcycle is available from any Harley-Davidson dealer.

Installation

1. See Figure 1, below. Loosen the shifter-rod jam nuts (2).

CAUTION

Mount the shifter-linkage cover brackets under, not above, the shifter rod. Mounting the shifter-linkage cover brackets other than under the shifter rod could result in loose or lost brackets and shifter-linkage cover.

2. See the Service Parts illustration (Page 2). Fasten a mounting bracket (3) on the bottom side of the shifter rod between the ball screw shell at the rear end of the rod and the jam nut. Torque the jam nut on the shifter rod to 80-120 **in-lbs** (9.0-13.6 Nm).
3. Fasten the remaining mounting bracket on the bottom side of the shifter rod between the ball screw shell at the front end of the rod and the jam nut. Torque the jam nut to 80-120 **in-lbs** (9.0-13.6 Nm).

4. Position the cover on top of the linkage and examine the fit.
 - If the linkage must be adjusted to accept the cover, proceed to Step 5.
 - If the cover fits properly, proceed to Step 8.
5. See Figure 1 (below) and SHIFTER LINKAGE, ADJUSTMENT in the Service Manual. To adjust the length of the linkage, remove the link attaching nut (5), lock washer and flat washer at the forward ball screw.

6. Loosen the jam nut (2) at the front end of the shifter rod, and remove the mounting bracket installed in Step 3. Rotate the forward ball screw shell to achieve the proper length to allow mounting of the cover.
7. Re-attach the ball screw to the shifter lever with the flat washer, lock washer and nut removed in Step 5. Torque the nut to 70-90 **in-lbs** (7.9-10.2 Nm).

8. See the Service Parts illustration inset on Page 2. Bend the tabs of each mounting bracket toward the jam nut.
9. Fasten the cover (1) to the mounting brackets using the two short screws (2) from the kit. Torque the screws to 8-10 **ft-lbs** (10.8-13.6 Nm).
10. If the linkage needed adjustment (Steps 5 through 7), the position of the shift foot levers (6) may have changed.

To return the levers to their original position, loosen the socket head screws holding the levers to the shaft. Pull the levers from the shaft, rotate them to the desired angle and slide them back onto the shaft.

Torque the screws to 18-22 **ft-lbs** (24.4-29.8 Nm).

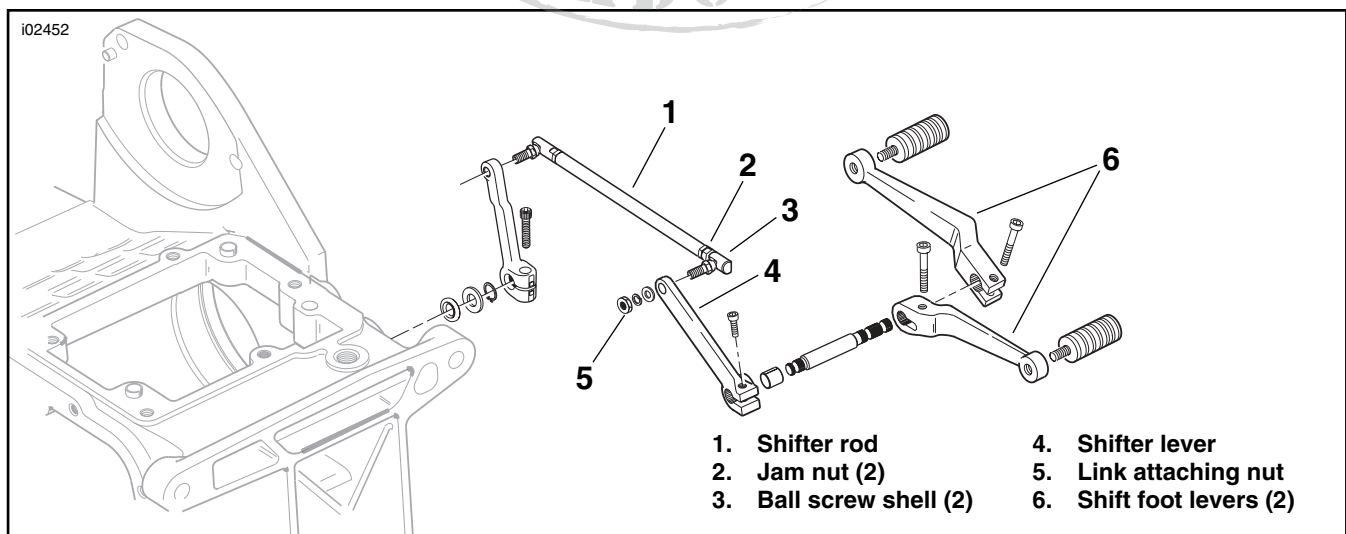

Figure 1. Stock Shifter Linkage



Service Parts

Part No. 46301-01 & Others | Date 09/03

Shifter Linkage Cover

i02397b

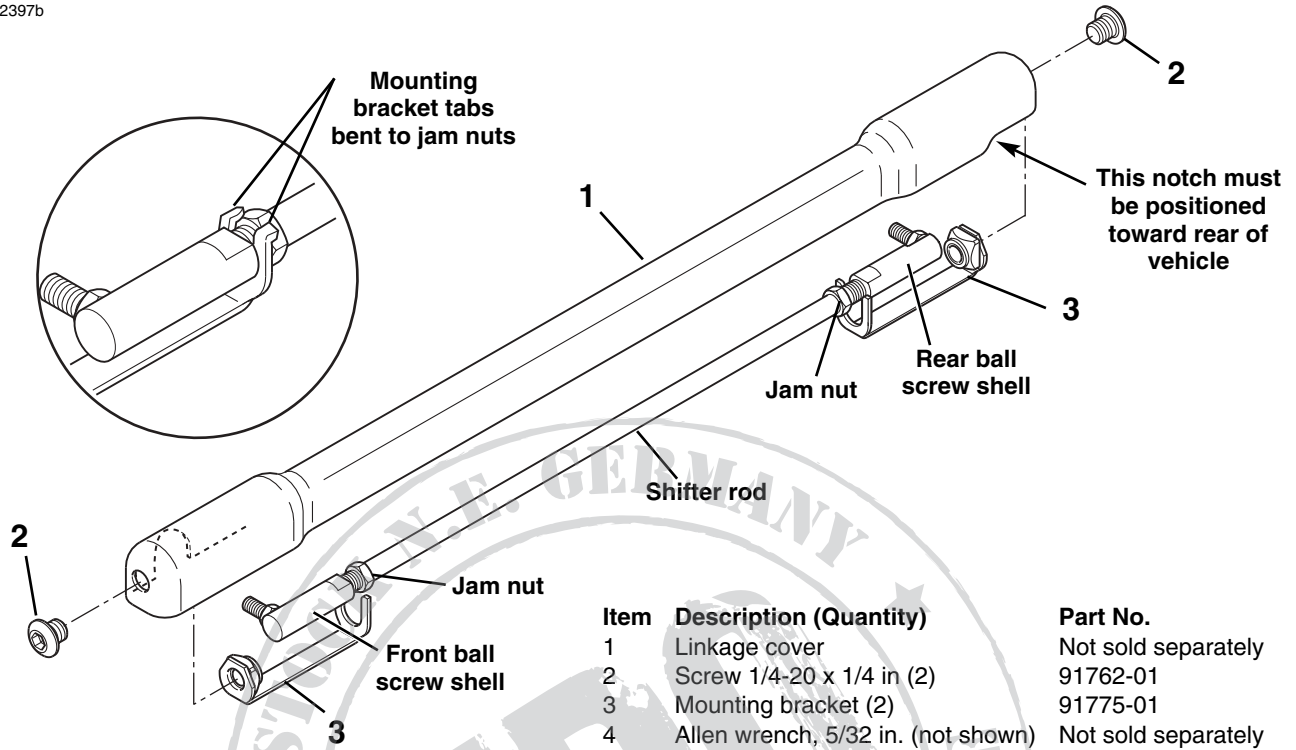

Item	Description (Quantity)	Part No.
1	Linkage cover	Not sold separately
2	Screw 1/4-20 x 1/4 in (2)	91762-01
3	Mounting bracket (2)	91775-01
4	Allen wrench, 5/32 in. (not shown)	Not sold separately

