



# INSTRUCTIONS

-J02549

REV. 2005-02-24

## DECORATIVE FL FORK SLIDER COVERS

### GENERAL

#### Kit Number

46116-03

#### Models

This kit fits 1949-1984 FL, 1980 and later FLT, FLHT, FLHR, and FLTR model motorcycles.

#### Additional Parts Required

### WARNING

The rider's safety depends upon the correct installation of this kit. Use the appropriate service manual procedures. If the procedure is not within your capabilities or you do not have the correct tools, have a Harley-Davidson dealer perform the installation. Improper installation of this kit could result in death or serious injury. (00333a)

#### NOTE

This instruction sheet references Service Manual information. A Service Manual for your model motorcycle is required for this installation and is available from a Harley-Davidson Dealer.

#### Kit Contents

See Figure 3 and Table 1.

### INSTALLATION

The chrome fork sliders included in this kit install in the same manner as the original equipment parts. Refer to the Service Manual for proper installation procedures.

1. Place suitable blocking under the frame to raise the front wheel several inches off the floor. For best results, use a hydraulic center stand on a level surface.
2. Remove the front fender, front brake caliper(s), and front wheel according to instructions found in the Chassis section of the applicable Service Manual. Save all hardware for installation.

#### FLHT/C/U:

- a. Remove fairing cap. See Upper Fairing/Windshield (FLHT/C/U Fairing Cap, Removal in applicable Service Manual. Save hardware for installation.
- b. Move to front of motorcycle. Loosen the two upper outer fairing screws. Remove the two lower outer fairing screws. Save hardware for installation.
- c. Remove two screws from lower fork bracket to release passing lamp bracket, chrome skirt and inner fairing. Remove chrome skirt. Save hardware for installation.

#### FLTR:

- a. Remove instrument nacelle. See Upper Fairing/Windshield (FLTR) Instrument Nacelle, Removal in the applicable Service Manual. Save hardware for installation.

#### FLHR/C/S:

- a. Remove headlamp nacelle. See Windshield/Headlamp Nacelle (FLHR/C/S), Nacelle Removal (FLHR/C) or Nacelle Removal (FLHRS). Save hardware for installation.

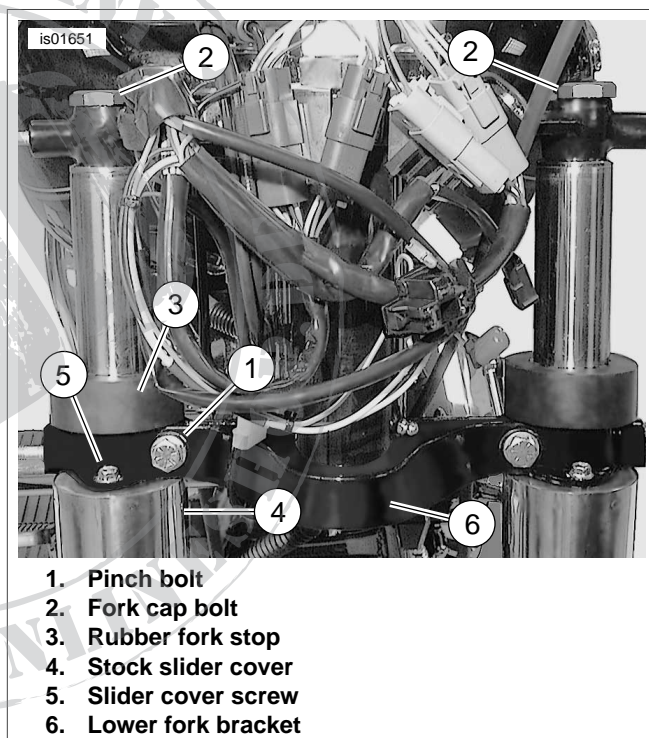

Figure 1. Fork Components (FLHR/C/S Shown)

3. See Figure 1. Standing at front vehicle, loosen pinch bolt (1) (with lockwasher) on left side of lower fork bracket, but do not remove.
4. Loosen fork cap bolt (2) from fork tube plug at top of fork tube, but do not remove at this time.
5. Spray glass cleaner on fork tube above the rubber fork stop (3). After lubricating surface, move rubber fork stop up fork tube until it contacts bottom of upper fork bracket.
6. Holding fork slider to prevent fork from dropping, remove fork cap bolt (2) from fork tube plug. Slide fork tube down and out of upper fork bracket, rubber fork stop (3), lower fork bracket (6) and slider cover (4).

7. Thread fork cap bolt (2) back onto fork tube plug to prevent loss of fork oil while handling.
8. Remove the two screws (5) securing the existing slider cover (4) and remove and discard cover. Save screws for installation.



**Figure 2. Install Decorative Slider Cover**

9. See Figure 2. Obtain the new Decorative Cover from kit. Using the screws (1) saved in Step 8, align the new slider cover (2) and install to the lower fork bracket. Tighten the screws to 60-120 **in-lbs** (6.8-13.6 Nm).
10. See Figure 1. Unthread the fork cap bolt (1) from the fork tube plug.
11. See Figure 1. Standing at front of vehicle, slide fork through new slider cover, lower fork bracket (6), fork stop (3), and upper fork bracket. Install fork cap bolt (2).
12. Move rubber fork stop down fork tube until it contacts top of the lower fork bracket. Lubricate surfaces with glass cleaner, if necessary to ease movement.
13. Install pinch bolt (with lockwasher) on left side of lower fork bracket. Tighten pinch bolt to 30-35 ft-lbs (41-48 Nm).
14. Tighten fork cap bolt to 50-60 ft-lbs (68-81 Nm).
15. Perform procedures 6 through 14 for the opposite fork tube and slider.
16. Install the front fender and wheel. See Front Fender, Installation, Front Wheel, Installation in applicable Service Manual.

**NOTE**

Verify that there is no contact made between the slider covers and the fender when the suspension is fully compressed. It is recommended that a Harley-Davidson dealer perform this check.

17. Obtain the two Bar and Shield Logos from kit. Using isopropyl alcohol, thoroughly clean the recessed area on the slider where the logo will be applied. Remove the adhesive backing then align and press the logo in place. Hold for

30 seconds. Repeat for the remaining logo on opposite slider.

**FLHT/C/U:**

- a. Slide the chrome skirt into position between passing lamp bracket and inner fairing. To avoid possible wire damage, be sure that trim strip is installed on top edge of skirt. Install two screws to secure passing lamp bracket, chrome skirt and inner fairing to lower fork bracket.
- b. Move to the front of the motorcycle. Install two lower outer fairing screws. Tighten two upper outer fairing screws.
- c. Install fairing cap. See Upper Fairing/Windshield (FLHT/C/U), Fairing Cap, Installation in applicable Service Manual.

**FLTR:**

- a. Install instrument nacelle. See Upper Fairing/Windshield (FLTR), Instrument Nacelle, Installation in applicable Service Manual.

**FLHR/C/S:**

- a. Install headlamp nacelle. See Windshield/Headlamp Nacelle (FLHR/C/S), Nacelle Installation (FLHR/C) or Nacelle Installation (FLHRS).

**SERVICE PARTS**

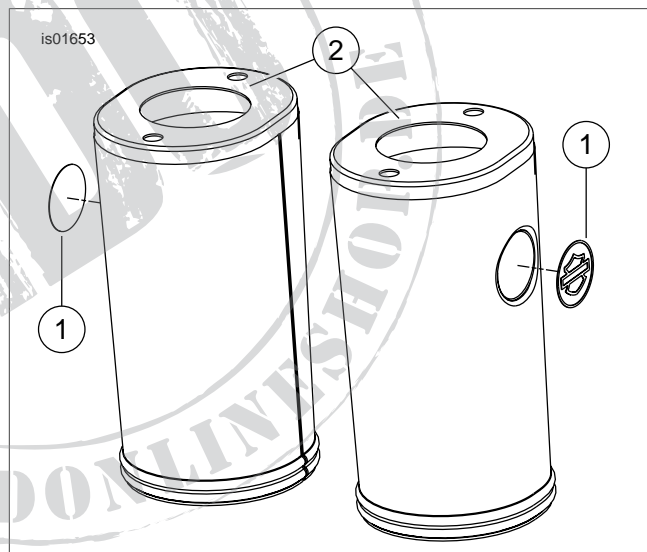

**Figure 3. Service Parts: Decorative Fork Slider Covers**

**Table 1. Service Parts**

Item	Description (Quantity)	Part Number
1	Logo, bar and shield emblem (2)	13883-00
2	Cover, fork slider (2)	Not Sold Separately