



INSTRUCTIONS

-J02723

REV. 2007-08-30

AXLE CAP NUT KIT (CHROME)

GENERAL

Kit Number

45813-03

Models

For model fitment information, please see the P&A Retail Catalog or the Parts and Accessories section of www.harley-davidson.com (English only).

NOTE

A Service Manual for your model motorcycle is available from a Harley-Davidson Dealer.

Kit Contents

See Figure 2 and Table 1.

INSTALLATION

1. Secure the front wheel of the motorcycle.
2. Remove one hex nut, lockwasher and flat washer attaching the axle holder to the right-side fork damper tube.
3. Assemble a chrome flat washer, split lockwasher and cap nut from the kit to the fork damper stud, but do not fully tighten at this time.
4. Repeat with the remaining nut, lockwasher and flat washer on the other stud.
5. **For 2000 and later models:** See Figure 1. Insert a 7/16 inch drill bit (3) into the hole in the front axle (2). Pull the right-side fork leg (1) so that it just contacts the drill bit.

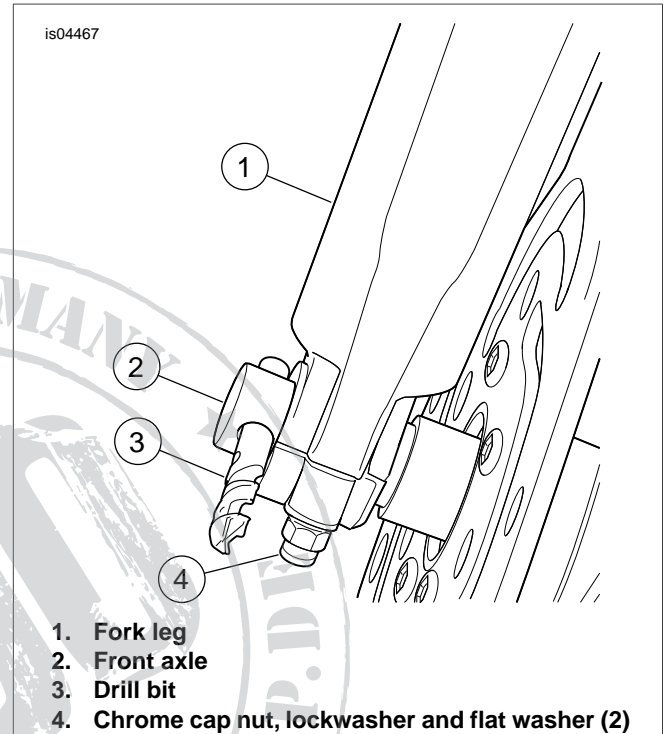

Figure 1. Align the Front Wheel

6. Tighten the new chrome cap nuts (4) to 9-13 ft-lbs (12-18 Nm).

SERVICE PARTS

is04468

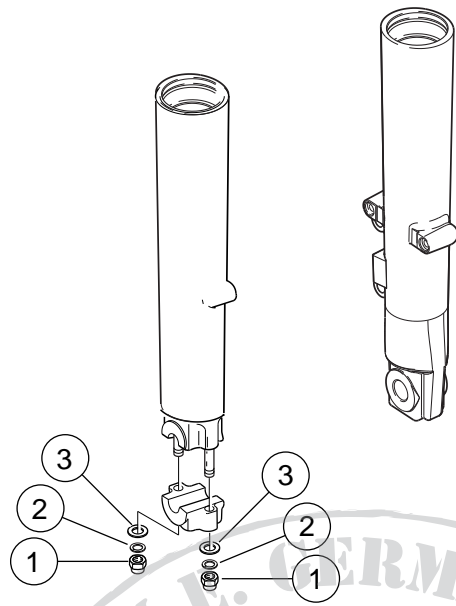

Figure 2. Service Parts: Front Axle Cap Nut Kit

Table 1. Kit Contents

Description (Quantity)	Part Number
Cap nut, 5/16-18 (chrome) (2)	8024
Lockwasher, split, 5/16 inch (chrome) (2)	94081-90T
Washer, flat, 5/16 inch (chrome) (2)	6330