



INSTRUCTIONS

-J02573

REV. 2007-08-17

CHROME REAR BRAKE RESERVOIR COVER KIT

GENERAL

Kit Number

45762-04

Models

For model fitment information, please see the P&A Retail Catalog or the Parts and Accessories section of www.harley-davidson.com (English only).

Additional Parts Required

⚠ WARNING

The rider's safety depends upon the correct installation of this kit. Use the appropriate service manual procedures. If the procedure is not within your capabilities or you do not have the correct tools, have a Harley-Davidson dealer perform the installation. Improper installation of this kit could result in death or serious injury. (00333a)

Kit Contents

See Figure 1 and Table 1.

INSTALLATION

1. Remove and discard the screw and washer holding the rear brake master cylinder reservoir to the motorcycle frame.
2. See the Figure 1. Obtain the chrome screw (2) and washer (3) from the kit. Place the washer onto the screw threads.
3. Position the chrome rear brake reservoir cover (1) over the reservoir, lining up the holes. Fasten with the chrome screw and washer using the T27 TORX® key (6) from the kit. Tighten securely.

4. Slowly unscrew the original reservoir cap. Note the orientation of the reservoir gasket and the gasket collar, which may come off with the cap. Discard the original reservoir cap only. Set the gasket and collar aside for re-installation.

⚠ CAUTION

Direct contact of D.O.T. 5 brake fluid with eyes can cause eye irritation, swelling, and redness. Avoid eye contact. In case of eye contact flush with large amounts of water and get medical attention. Swallowing large amounts of D.O.T. 5 brake fluid can cause digestive discomfort. If swallowed, obtain medical attention. Use in well ventilated area. KEEP OUT OF REACH OF CHILDREN. (00144a)

5. Refer to the Owner's Manual and follow the procedure to check the brake fluid level. Fill as needed with DOT 5 SILICONE HYDRAULIC BRAKE FLUID. Do not reuse old fluid. Only use DOT 5 hydraulic brake fluid from a sealed container.
6. Set the reservoir gasket back onto the lip of the reservoir and position the gasket collar onto the gasket.
7. Carefully position the new chrome cap (4) over the reservoir and screw it on. Tighten securely.
8. Clean the indented top surface of the new cap with a 50-50 mixture of isopropyl alcohol and water and let it dry.
9. Peel the paper backing from the Bar and Shield emblem (5). Turn the emblem to the desired orientation and press it firmly into place on the top of the chrome cap.

⚠ WARNING

After repairing the brake system, test brakes at low speed. If brakes are not operating properly, testing at high speeds can cause loss of control, which could result in death or serious injury. (00289a)

SERVICE PARTS

is02064

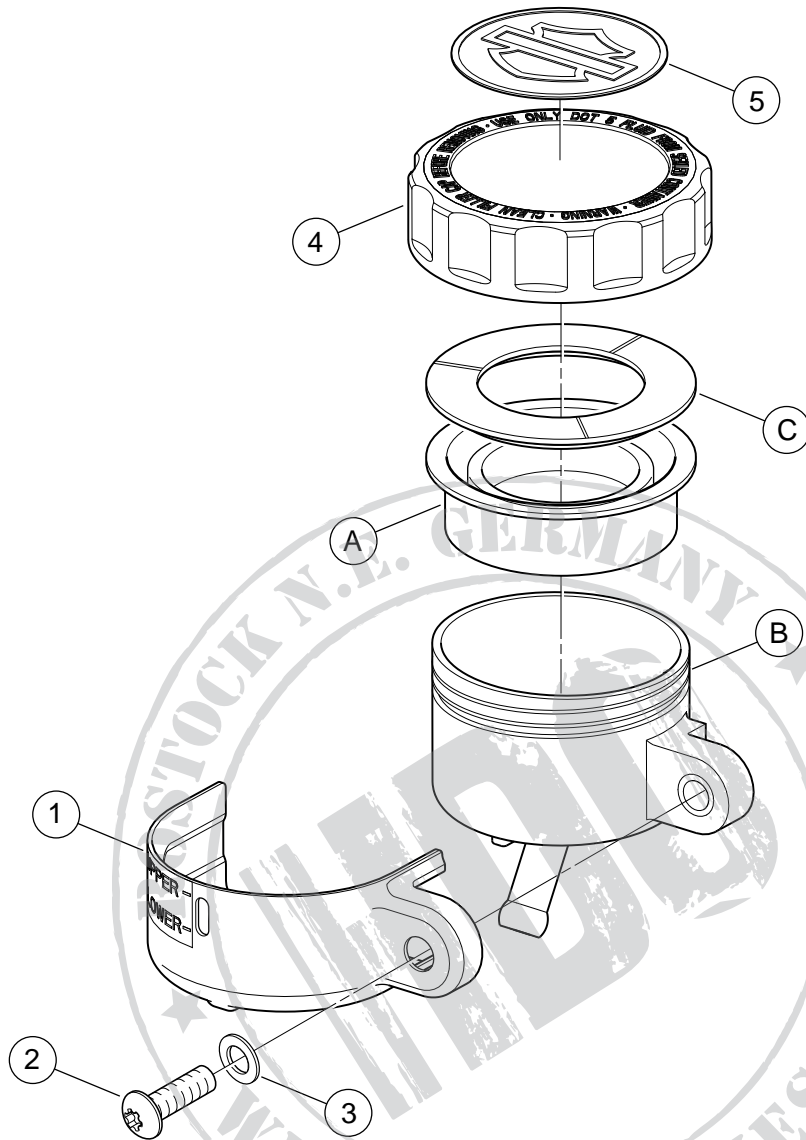

Figure 1. Service Parts: Chrome Rear Brake Reservoir Cover Kit

Table 1. Service Parts Table

Item	Description (Quantity)	Part Number
1	Cover, rear brake reservoir (chrome)	Not sold
2	Screw, button head, T27 TORX, 1/4-20 x 3/4 inch (chrome)	94593-98
3	Washer, flat (chrome)	6287
4	Cap, master cylinder reservoir (chrome)	Not sold
5	Emblem, Bar and Shield logo	Not sold
6	Torx key, T27 (not shown)	Not Sold
Items mentioned in text, but not included in kit:		
A	Reservoir gasket	
B	Rear brake master cylinder reservoir	
C	Reservoir gasket collar	