



# INSTRUCTIONS

-J05357

REV. 2011-05-12

## DYNA FORK SLIDER KITS

### GENERAL

#### Kit Number

45500064, 45500065, 45500066, 45500067 (chrome),  
45500073, 45500074 (gloss black)

#### Models

For model fitment information, see the P&A Retail Catalog or the Parts and Accessories section of [www.harley-davidson.com](http://www.harley-davidson.com) (English only).

#### NOTE

*The fork sliders are direct replacements for the standard equipment fork sliders.*

#### Additional Parts Required

Harley-Davidson TYPE E FORK OIL (Part Number 99884-80) will be required.

Loctite® 243 Threadlocker and Sealant - Blue (Part Number 99642-97).

Loctite® Anti-Seize Lubricant (Part Number 98960-97).

#### WARNING

**The rider's safety depends upon the correct installation of this kit. Use the appropriate service manual procedures. If the procedure is not within your capabilities or you do not have the correct tools, have a Harley-Davidson dealer perform the installation. Improper installation of this kit could result in death or serious injury. (00333a)**

#### NOTE

*This instruction sheet references service manual information. A service manual for your model motorcycle is required for this installation and is available from a Harley-Davidson Dealer.*

#### Tools Required

- Air impact wrench
- Torque wrench
- Fork spring compression tool
- Damper tube extension tool
- Fork Tube Holder HD-41177
- Front Fork Oil Level Gauge HD-59000-B
- Fork Seal and Bushing Tool HD-45305

#### Kit Contents

See Figure 2 and Table 1.

### INSTALLATION

The fork sliders included in this kit install in the same manner as the original equipment parts. Refer to the service manual for proper installation procedures.

Pay close attention to all warnings, cautions, and torque specifications when installing these fork sliders.

#### NOTE

*Prior to installation of this kit, check the bores of the new sliders to be certain they are free of dirt and debris or damage to the new sliders may occur.*

1. Support the motorcycle so the front end is off the floor and the forks are fully extended.
2. Remove front fender, front brake caliper(s), front wheel and front forks following the instructions in the CHASSIS section of the service manual.

#### NOTE

*On some models other parts will also need to be removed to access the front forks. See the service manual.*

#### WARNING

**Wear safety glasses or goggles when servicing fork assembly. Do not remove slider tube caps without relieving spring preload or caps and springs can fly out, which could result in death or serious injury. (00297a)**

3. Disassemble the front fork tubes according to instructions in the service manual, and replace the original fork sliders with the sliders (see Figure 2, items 1 and 3) from the kit.
4. Assemble the front fork tubes, replacing worn seals, bushings or other additional items as needed. Two **new** slider oil seals (5) are included in the kit.
5. Fill with TYPE E FORK OIL (Harley-Davidson part number 99884-80) according to the instructions found in the service manual.
6. Install the front fork and any parts that were removed to access the front forks. Install the front fender, wheel, and caliper according to the instructions found in the CHASSIS section of the service manual.

#### WARNING

**Federal Motor Vehicle Safety Standard (FMVSS) 108 requires motorcycles to be equipped with rear and side reflectors. Be sure rear and side reflectors are properly mounted. Poor visibility of rider to other motorists can result in death or serious injury. (00336b)**

### NOTES

The original equipment front fork reflectors located on both sliders will be removed, cleaned and installed on the new chrome sliders.

Ambient temperature should be **at least 60° F (16° C)** for proper adhesion of the reflectors to the sliders.

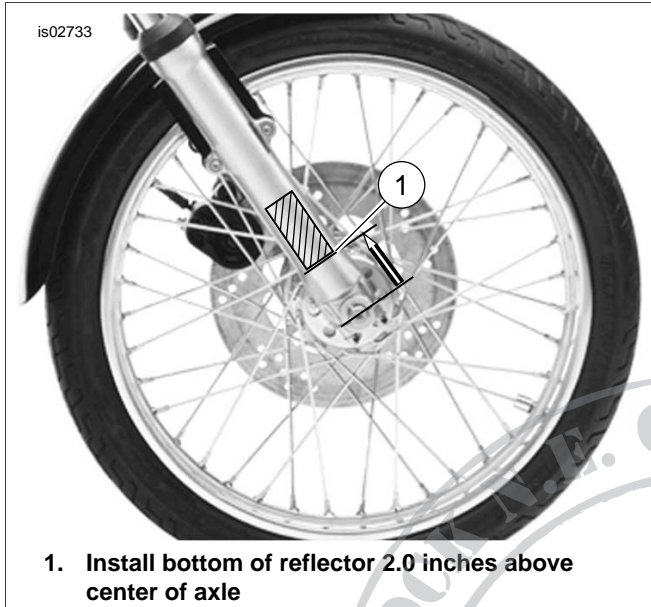

Figure 1. Reflector Placement

- Using a piece of dental floss (or similar material) in a back and forth motion, loosen the reflector (Figure 2, A and B) from fork slider at both ends. Rotate reflector from side to side until it can be removed. Retain reflector for future use.

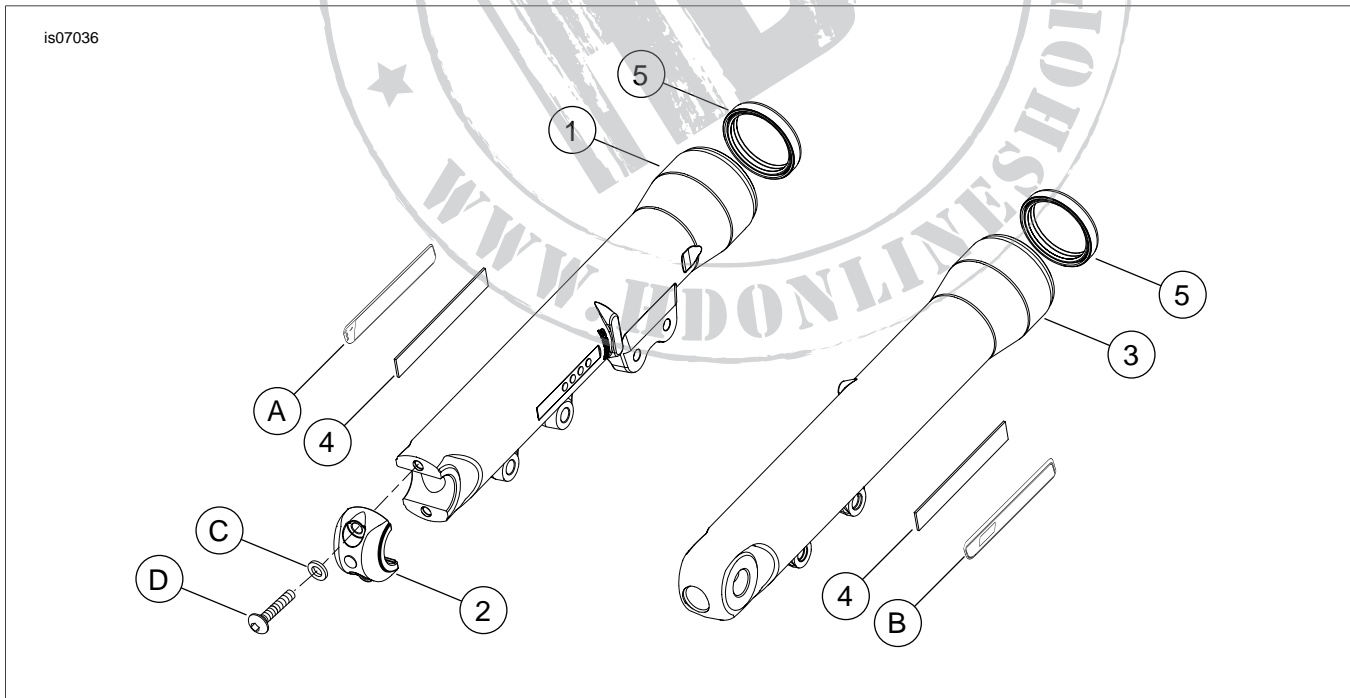

Figure 2. Service Parts: Dyna Fork Slider Kits

Repeat procedure on the opposite side fork slider.

- Remove any excess adhesive from both reflectors. Surface must be clean for reinstallation.

### NOTE

The bottom edge of the reflector should be two inches (50 mm) above the center of the axle shaft.

- Peel the liner from one side of the foam double-sided tape. Position the tape to the back of the reflector, and press firmly into place.

Peel the remaining liner from the tape. Place the reflector in position on the fork slider as shown in Figure 1, and press firmly into place.

Repeat the procedure on the opposite side fork slider.

### NOTE

Allow **AT LEAST 24 hours** after applying the reflectors before exposing the area to vigorous washing, strong water spray or extreme weather.

### WARNING

Whenever a wheel is installed and before moving the motorcycle, pump brakes to build brake system pressure. Insufficient pressure can adversely affect brake performance, which could result in death or serious injury. (00284a)

- Pump brakes prior to test riding vehicle.
- Test ride the vehicle to verify proper fork travel and rebound.

### SERVICE PARTS

**Table 1. Service Parts: Dyna Chrome Fork Slider Kits**

Kit	Item	Description (Quantity)	Part Number
Kit 45500064	1	Fork slider, right side (chrome)	46587-06B
	2	Axle cap (chrome)	41860-06A
	3	Fork slider, left side (chrome)	45500068
	4	Tape, double sided foam (2)	53791-06
	5	Oil seal (2)	46514-01A
Kit 45500065	1	Fork slider, right side (chrome)	48750-08A
	2	Axle cap (chrome)	41860-06A
	3	Fork slider, left side (chrome)	45500069
	4	Tape, double sided foam (2)	53791-06
	5	Oil seal (2)	46514-01A
Kit 45500066	1	Fork slider, right side (chrome)	46587-06B
	2	Axle cap (chrome)	41860-06A
	3	Fork slider, left side (chrome)	45500070
	4	Tape, double sided foam (2)	53791-06
	5	Oil seal (2)	46514-01A
Kit 45500067	1	Fork slider, right side (chrome)	45500072
	3	Fork slider, left side (chrome)	45500071
	4	Tape, double sided foam (2)	53791-06
	5	Oil seal (2)	45875-84A
Kit 45500073	1	Fork slider, right side (gloss black)	45500100
	2	Axle cap (gloss black)	45500103
	3	Fork slider, left side (gloss black)	45500099
	4	Tape, double sided foam (2)	53791-06
	5	Oil seal (2)	46514-01A
Kit 45500074	1	Fork slider, right side (gloss black)	45500100
	2	Axle cap (gloss black)	45500103
	3	Fork slider, left side (gloss black)	45500101
	4	Tape, double sided foam (2)	53791-06
	5	Oil seal (2)	46514-01A
<b>Original equipment parts that are reused:</b>			
	A	Reflector, amber, right	59481-00
	B	Reflector, amber, left	59482-00
	C	Axle cap washer (2) except FLD	7062
	D	Axle cap bolt (2) except FLD	4042