



INSTRUCTIONS

-J05112

REV. 2010-05-21

LOWER FORK SLIDERS

GENERAL

Kit Numbers

45500014, 45500015

Models

For model fitment information, see the P&A Retail Catalog or the Parts and Accessories section of www.harley-davidson.com (English only).

Additional Parts Required

Harley-Davidson Type E Fork Oil (part number 99884-80) will be required.

⚠ WARNING

The rider's safety depends upon the correct installation of this kit. Use the appropriate service manual procedures. If the procedure is not within your capabilities or you do not have the correct tools, have a Harley-Davidson dealer perform the installation. Improper installation of this kit could result in death or serious injury. (00333a)

NOTE

This instruction sheet references service manual information. A service manual for your model motorcycle is required for this installation and is available from a Harley-Davidson Dealer.

Tools Required

See the service manual for additional tools required to install this kit.

Kit Contents

See Figure 2 and Table 1.

REMOVAL

1. Support the motorcycle so the front end is off the floor and the forks are fully extended.
2. Follow the instructions in the service manual to remove necessary components.
3. Drain and remove the front forks following the instructions in the service manual.

⚠ WARNING

Wear safety glasses or goggles when servicing fork assembly. Do not remove slider tube caps without relieving spring preload or caps and springs can fly out, which could result in death or serious injury. (00297a)

4. See Figure 1. Using a piece of dental floss (or similar material) in a back and forth motion, loosen reflector from

fork slider at both ends. Rotate reflector from side-to-side until it can be removed. Save reflector for installation.

Repeat procedure on the opposite side fork slider.

Peel off any excess adhesive from both reflectors. Surface must be clean for installation.

5. Disassemble the front fork tubes according to instructions in the service manual.

INSTALLATION

NOTES

The fork sliders included in this kit install in the same manner as the original equipment parts. Refer to the service manual for proper installation procedures.

Prior to installation of this kit, check the bores of the new sliders to be certain they are free of dirt and debris or damage to the new sliders may occur.

1. Assemble the front fork tubes, replacing worn seals, bushings or other items as needed.

NOTE

Do not use an impact wrench to tighten the drain screws. Damage to the drain screws could result.

2. Tighten the drain screws to 52-78 **in-lbs** (5.8-8.8 Nm).
3. Fill with Type E Fork Oil (part number 99884-80) according to the instructions in the service manual.
4. Install the front fork and any parts that were removed to access the front forks following the instructions in the service manual.

⚠ WARNING

Federal Motor Vehicle Safety Standard (FMVSS) 108 requires motorcycles to be equipped with rear and side reflectors. Be sure rear and side reflectors are properly mounted. Poor visibility of rider to other motorists can result in death or serious injury. (00336b)

NOTES

Ambient temperature should be at least 60 °F (16 °C) for proper adhesion of the reflectors.

Allow AT LEAST 24 hours after applying the reflectors before exposing the area to vigorous washing, strong water spray or extreme weather.

5. Peel off one side of backing on foam double-sided tape (7). Press firmly on tape to secure it to reflector. Repeat double-sided adhesive tape installation on remaining reflector.

See Figure 1. The bottom edge of reflector should be 2.0 inches (50 mm) above the center of the axle shaft. Remove second side (outside surface) of adhesive backing. Place

reflector in position (1) and press reflector firmly into place to activate the adhesive. Repeat for remaining reflector.

WARNING

Whenever a wheel is installed and before moving the motorcycle, pump brakes to build brake system pressure. Insufficient pressure can adversely affect brake performance, which could result in death or serious injury. (00284a)

6. Pump brakes prior to test ride.
7. Test ride the vehicle to verify proper fork travel and rebound.



Figure 1. Reflector Placement

SERVICE PARTS

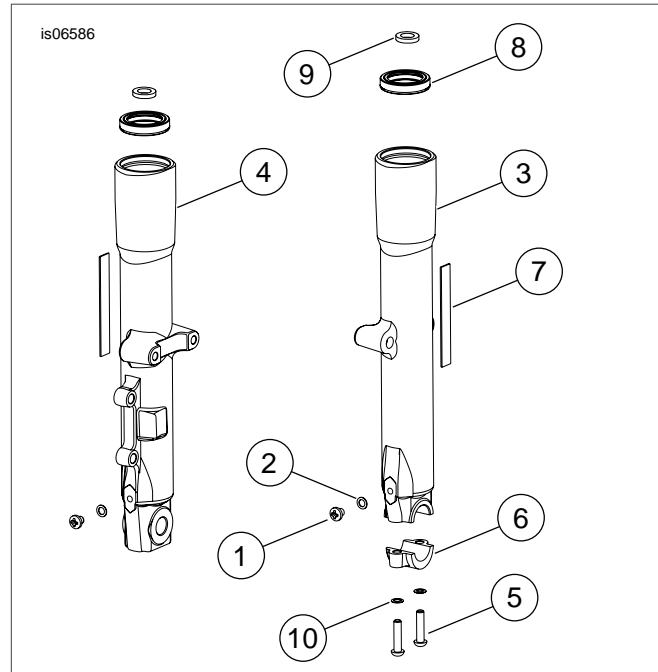

Figure 2. Service Parts: Lower Slider Kit

Table 1. Service Parts: Lower Fork Sliders

Item	Description (Quantity)	Part Number
1	Bolt and washer (2) (Kit 45500015)	45858-77
	Screw (2) (Kit 45500014)	45369-99
2	Washer (2) (Kit 45500014)	45692-99
	Fork slider, right side, black (Kit 45500015)	48654-09
3	Fork slider, right side, chrome (Kit 45500014)	46484-08A
	Fork slider, left side, black (Kit 45500015)	45500017
4	Fork slider, left side, chrome (Kit 45500014)	45500016
	Screw (2)	4042
5	Axle holder, black (Kit 45500015)	48655-09
	Axle holder, chrome (Kit 45500014)	46658-07
7	Tape, double-sided foam (2)	53791-06
8	Oil seal (2)	45875-84A
9	Packing, oil seal (2)	45733-48
10	Lockwasher (2)	7062