



INSTRUCTIONS

-J04342

REV. 2007-04-24

HAND LEVER KITS

GENERAL

Kit Numbers

44994-08, 45075-08, 45459-08, 46710-08, 46982-08

Models

For model fitment information, please see the P&A Retail Catalog or the Parts and Accessories section of www.harley-davidson.com (English only).

WARNING

The rider's safety depends upon the correct installation of this kit. Use the appropriate service manual procedures. If the procedure is not within your capabilities or you do not have the correct tools, have a Harley-Davidson dealer perform the installation. Improper installation of this kit could result in death or serious injury. (00333a)

NOTE

This instruction sheet references Service Manual information. A Service Manual for your model motorcycle is required for this installation and is available from a Harley-Davidson Dealer.

Kit Contents

See Figure 2 and Table 1.

BRAKE LEVER INSTALLATION

CAUTION

Do not remove or install the master cylinder assembly without first positioning a 5/32-inch (4 mm) thick insert between the brake lever and lever bracket. Removing or installing the master cylinder assembly without the insert in place may result in damage to the rubber boot and plunger on the front stoplight switch. (00324a)

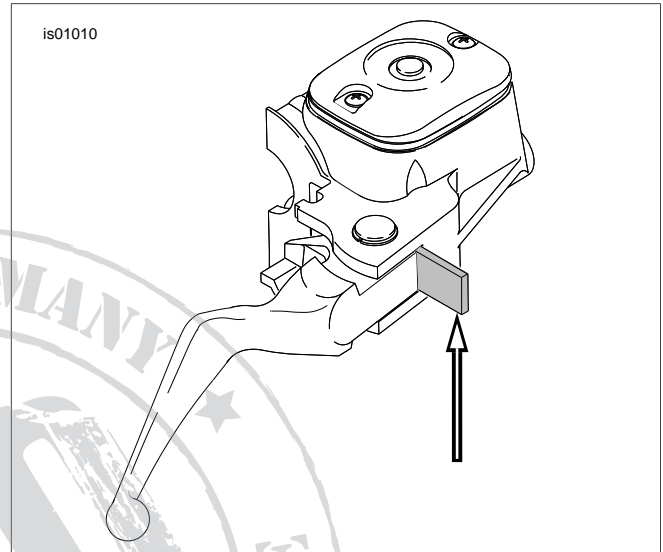

Figure 1. 5/32 in. (4 mm) Cardboard Insert

1. See Figure 1. Squeeze the brake lever and place the cardboard insert between the brake lever and lever bracket.

NOTE

Use the eyelet of an ordinary cable strap if the cardboard insert is not available.

NOTE

Do not remove the handlebar clamp or switch housing assembly to remove the brake lever.

WARNING

Wear safety glasses or goggles when removing or installing retaining rings. Retaining rings can slip from the pliers and could be propelled with enough force to cause serious eye injury. (00312a)

2. See the Figure 2 and the FRONT BRAKE MASTER CYLINDER section of the Service Manual. Remove the retaining ring (4) from the groove in the pivot pin (B) and discard retaining ring.
3. Remove the pivot pin and retain for re-use. Remove and discard the original equipment brake lever and pivot lever bushing.

NOTE

New brake levers come with the pivot lever bushing installed.

NOTE

Follow the instructions in Steps 3 and 4 carefully in order to prevent the actuating tab on the brake lever from damaging the rubber boot and plunger of the front stoplight switch.

4. Gently press and hold the piston cap (A) forward with a screwdriver. Slip the brake lever into position and align the pivot pin holes.
5. Install the pivot pin removed in Step 2 and new retaining ring (4) from kit.
6. Check the front brake for proper operation. There should be no free play in the hand lever. A slight preload is permissible.

⚠ WARNING

A plugged or covered relief port can cause brake drag or lock-up, which could lead to loss of control, resulting in death or serious injury. (00288a)

7. To verify proper operation of the master-cylinder relief port, actuate the brake lever with the reservoir cover and

gasket removed. A slight spurt of fluid will break the surface if internal components are working properly.

8. Reinstall the master cylinder cover.

⚠ WARNING

Be sure that all lights and switches operate properly before operating motorcycle. Low visibility of rider can result in death or serious injury. (00316a)

9. Check that the stop light goes on when the brake lever is actuated.

CLUTCH LEVER INSTALLATION

See the CLUTCH CONTROL section of the appropriate Service Manual for all clutch lever removal, installation and adjustment procedures.

SERVICE PARTS

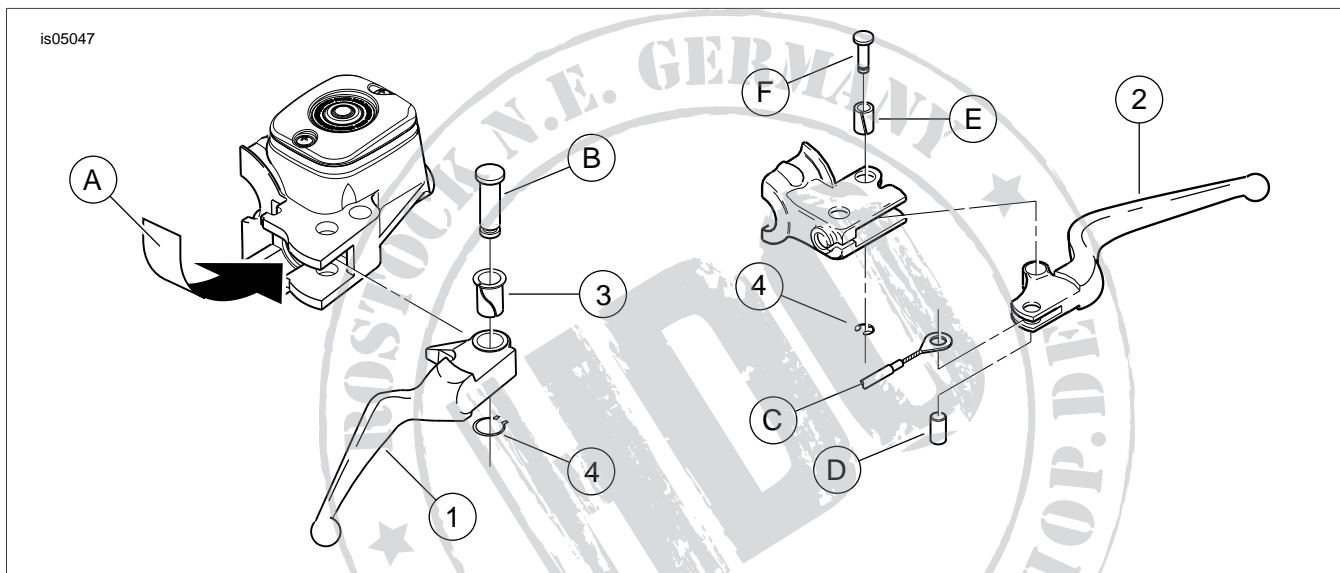

Figure 2. Service Parts: Hand Lever Kits

Table 1. Service Parts Table

Kit	Item	Description (Quantity)	Part Number
Kit 44994-08	1	Brake lever, black	44995-08
	2	Clutch lever, black	44996-07
	3	Bushing, pressed into brake lever	45423-96
	4	Retaining ring (2)	11143
Kit 45075-08	1	Brake lever, chrome	45076-08
	2	Clutch lever, chrome	45077-07
	3	Bushing, pressed into brake lever	45423-96
	4	Retaining ring (2)	11143
Kit 46710-08	1	Brake lever, flame	46712-08
	2	Clutch lever, flame	46713-07
	3	Bushing, pressed into brake lever	45423-96
	4	Retaining ring (2)	11143

Table 1. Service Parts Table

Kit	Item	Description (Quantity)	Part Number
Kit 46982-08	1	Brake lever, skull	46983-08
	2	Clutch lever, skull	46984-07
	3	Bushing, pressed into brake lever	45423-96
	4	Retaining ring (2)	11143
Kit 45459-08	1	Brake lever, slotted, emblem mount	45391-08
	2	Clutch lever, slotted, emblem mount	45514-07
	3	Bushing, pressed into brake lever	45423-96
	4	Retaining ring (2)	11143
	5	Clutch emblem	44419-02
	6	Brake emblem	44418-02
Items mentioned in text, but not included in kit:			
	A	Press piston cap forward	
	B	Brake lever pivot pin	
	C	Clutch control cable (reference only)	
	D	Clutch cable anchor pin (reference only)	
	E	Clutch lever pivot pin bushing	
	F	Clutch lever pivot pin	

