



INSTRUCTIONS

-J06038

2014-11-12

DYNA CARTRIDGE FRONT FORK KIT

GENERAL

Kit Number

45400058

Models

For model fitment information, see the P&A Retail Catalog or the Parts and Accessories section of www.harley-davidson.com (English only).

Installation Requirements

- Proper installation of this kit also requires the following special tools:
- Loctite[®] 565 Thread Sealant (99818-97)
- Harley-Davidson[®] Type E Fork Oil (62600026)
- Harley-Davidson[®] Seal Grease (11300005)
- Fork Tube Holder (HD-41177)
- Fork Seal/Bushing Tool (HD-45305)
- Front Fork Oil Level Gauge (HD-59000B)
- Front Fork Spring Compressing Tool (HD-45966)
- Extension tool (HD-45966-1)

⚠ WARNING

The rider's safety depends upon the correct installation of this kit. Use the appropriate service manual procedures. If the procedure is not within your capabilities or you do not have the correct tools, have a Harley-Davidson dealer perform the installation. Improper installation of this kit could result in death or serious injury. (00333a)

NOTE

This instruction sheet references service manual information. A service manual for your model motorcycle is required for this installation and is available from a Harley-Davidson Dealer.

Kit Contents

See Figure 7 and Table 1.

REMOVAL

1. See the service manual. Remove the front fender, wheel and brakes.
2. See the service manual. Remove the front forks.

RIGHT SIDE

Fork Disassembly

1. See Figure 1. Install fork in Fork Tube Holder (HD-41177) as follows:

- a. Clamp end of tool (1) in vise in a horizontal position.

NOTE

Be aware fork bolt (C) is under spring-pressure, so have a firm grasp on bolt as the last thread is turned.

- b. See Figure 7. With the fork bolt (C) upward, clamp fork tube (D), between rubber pads on inboard side of tool. Tighten knobs until fork tube is securely held.

⚠ WARNING

Wear safety glasses or goggles when servicing fork assembly. Do not remove slider tube caps without relieving spring preload or caps and springs can fly out, which could result in death or serious injury. (00297a)

2. Slowly remove fork bolt and O-ring (2) from fork tube. Discard O-ring.
3. Remove the spring collar (17), flat washer (M) and spring (12) from the fork tube. Save flat washer for later use.
4. Remove fork assembly from fork tube holder. Turn fork upside down over drain pan to drain oil. For best results, slowly pump fork tube and fork slider (K) at least 10 times.
5. Install fork spring and spring collar back into fork tube.
6. Put a shop rag on the floor. Turn the fork assembly upside down. Press the end of the spring collar against the rag. Compress the spring. Remove the screw (14) with copper washer (10) from the bottom end of fork slider. Use air impact wrench for best results. Discard screw and copper washer.
7. Remove and discard fork spring and spring collar.
8. Push the damper tube (13) and rebound spring (I) free of fork tube by inserting a small diameter rod through the opening in the bottom of tube. Discard damper tube.

NOTE

To overcome any resistance, use the fork tube as a slide hammer: Push fork tube into fork slider and then pull it outward with a moderate amount of force. Repeat this sequence until fork tube separates from fork slider.

-J06038



Many Harley-Davidson[®] Parts & Accessories are made of plastics and metals which can be recycled. Please dispose of materials responsibly.

1 / 7

9. Using pick tool, remove retaining clip (F) between fork slider and fork tube. Do not expand or stretch retaining clip to remove from fork tube or clip may be damaged.
10. Remove fork tube from fork slider.
11. Slide dust seal (16), fork oil seal (8), slider washer (G) and slider bushing (H) off end of fork tube. Discard fork oil seal and dust seal.
12. Remove oil lock (J) from the end of fork tube (D) or the inside of the fork slider. Save oil lock for later use.

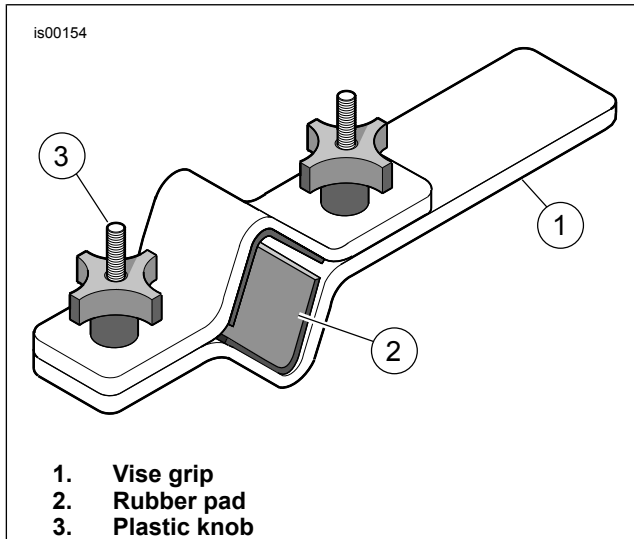

Figure 1. Fork Tube Holder (HD-41177)

Fork Assembly

NOTICE

Exercise caution to avoid scratching or nicking fork tube. Damaging tube can result in fork oil leaks after assembly. (00421b)

NOTE

Inspect parts for wear or damage. Replace or repair as necessary.

1. See Figure 7, assembly (B). Make sure that piston ring is installed on the damper tube with the cut-outs down. Place rebound spring (I) on **new** damper tube from kit (13). Insert damper tube into fork tube (D).
2. Insert spring (12) and spring collar (17) into fork tube, with dense section of coils toward damper tube. Push bottom of damper tube through the opening at the bottom end of the fork tube. Place oil lock (J) over end of damper tube.
3. Apply Loctite 565 Thread Sealant to screw (14). Position fork tube and damper tube in fork slider (K). Hold the assembly in place by exerting pressure on the spring. Install screw (14) with copper washer (10) from kit.
4. Tighten screw to $45 \pm 5 \text{ N}\cdot\text{m}$ ($33 \pm 4 \text{ ft}\cdot\text{lbs}$).
5. Coat inner diameter (ID) and outer diameter (OD) of slider bushing (H) with clean fork oil. Slide slider bushing down fork tube (either direction).
6. Slide slider washer (G) down fork tube until it contacts slider bushing (either direction).
7. Coat the ID of the **new** fork oil seal (8) with clean fork oil. Coat the OD of the fork oil seal with Harley-Davidson Seal Grease. With the lettering side facing up, slide fork oil seal down the fork tube until it contacts the slider washer.
8. See Figure 2. Obtain the Fork Seal/Bushing Tool (HD-45305) and proceed :
 - a. Slide the fork seal installer down the fork tube until it contacts the fork oil seal.
 - b. See Figure 2. Using the tool like a slide hammer, drive fork oil seal (with slider washer and slider bushing) down the fork tube until retaining clip groove is visible in fork slider ID.
 - c. See Figure 7. Slide the retaining clip (F) down the fork tube until it contacts the fork oil seal. Install retaining clip in the fork slider groove. Do not expand or stretch retaining clip to install on fork tube or clip may be damaged.
9. Install dust seal (16).
10. Remove spring collar and fork spring.

⚠ WARNING

Incorrect amount of fork oil can adversely affect handling and lead to loss of vehicle control, which could result in death or serious injury. (00298a)

11. Place slider in fork holder.
12. Fill fork tube as follows:
 - a. With fork tube compressed, pour Harley-Davidson Type E Fork Oil into the fork tube almost to the top.
 - b. Pump fork tube ten times to remove air from system.
13. Adjust the fork oil level, so that it is 130 mm (5.12 in) from the top of the fork tube with the fork tube compressed and the fork spring and spring collar removed.
 - a. See Figure 3. Obtain the Front Fork Oil Level Gauge (HD-59000B).
 - b. Loosen thumbscrew on metal ring and move it up or down the rod until the bottom of the ring is 130 mm (5.12 in) from the bottom of the rod. Tighten thumbscrew.
 - c. Push the plunger on the cylinder all the way in.
 - d. See Figure 3. Insert rod into top of fork tube until metal ring rests flat on top of fork tube.
 - e. Pull plunger to remove fork oil from fork tube. Observe fork oil through transparent tube to verify that oil is being drawn from fork.
 - f. Remove rod from fork tube. Push plunger into cylinder to eject excess fork oil into suitable container.

NOTE

Verify that the fork spring is installed with dense section of coils to the bottom.

- g. If necessary, repeat Steps 13(c) through 13(f). Level is correct when no fork oil is observed being drawn through transparent tube.
14. Install fork spring into the fork tube with the dense end down.
15. Install flat washer (M) on top of spring.
16. Install spring collar (17) on top of washer.
17. Install **new** O-ring (2) onto fork bolt (C).
18. Install fork tube bolt. Tighten to 55 ± 25 N·m (40.5 ± 18.5 ft-lbs).

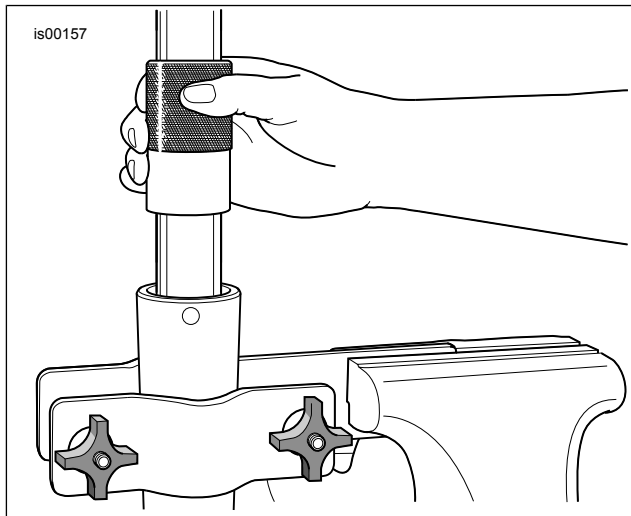

Figure 2. Install Fork Oil Seal

LEFT SIDE

Fork Disassembly

1. Obtain left fork assembly removed in earlier step.
2. See Figure 1. Install fork in Fork Tube Holder (HD-41177).
 - a. Clamp end of tool (1) in vise in a horizontal position.

NOTE

Be aware fork bolt (C) is under spring-pressure, so have a firm grasp on bolt as the last thread is turned.

- b. See Figure 7. With the fork bolt upward, clamp fork tube (D), between rubber pads on inboard side of tool. Tighten knobs until fork tube is securely held.

▲ WARNING

Wear safety glasses or goggles when servicing fork assembly. Do not remove slider tube caps without relieving spring preload or caps and springs can fly out, which could result in death or serious injury. (00297a)

3. Slowly remove and discard fork bolt (C) and O-ring (2) from fork tube.

4. Remove spring collar (17), flat washer (M) and fork spring (12) from the fork tube. Discard flat washer.
5. Remove fork assembly from fork tube holder. Turn fork upside down over drain pan to drain oil. For best results, slowly pump fork tube and fork slider (L) at least ten times.
6. Install fork spring and spring collar back into fork tube.
7. Put a shop rag on the floor. Turn the fork assembly upside down. Press the end of the spring collar against the rag. Compress the spring. Remove the screw (14) with copper washer (10) from the bottom end of fork slider. Use air impact wrench for best results. Discard screw and copper washer.
8. Remove and discard fork spring and spring collar.
9. Push the damper tube and rebound spring free of fork tube by inserting a small diameter rod through the opening in the bottom of tube. Discard damper tube, and rebound spring.

NOTE

To overcome any resistance, use the fork tube as a slide hammer: Push fork tube into fork slider. Pull it outward with a moderate amount of force. Repeat this sequence until fork tube separates from fork slider.

10. Using pick tool, remove retaining clip (F) between fork slider and fork tube. Do not expand or stretch retaining clip to remove from fork tube or clip may be damaged.
11. Remove fork tube from fork slider.
12. Slide dust seal (16), fork oil seal (8), slider washer (G) and slider bushing (H) off end of fork tube. Discard fork oil seal and dust seal.
13. Remove oil lock (J) from the end of fork tube (D) or the inside of the fork slider. Discard oil lock. Discard fork tube.

Fork Assembly

NOTICE

Exercise caution to avoid scratching or nicking fork tube. Damaging tube can result in fork oil leaks after assembly. (00421b)

NOTE

Inspect parts for wear or damage. Replace or repair as necessary.

1. See Figure 7 Assembly (A). Clamp the fork tube (15) up-side down in the fork tube holder. Insert tapered end of the **new** oil lock (9) in the end of the fork tube. Slide fork slider over the fork tube.
2. Keep the fork compressed and remove it from the fork tube holder. Clamp the fork slider right-side up in the fork tube holder. Slide the damper cartridge (7) into the fork assembly so that it seats in the center of the oil lock.
3. Push down on cartridge.

4. Apply Loctite 565 Thread Sealant to screw (11). Install screw with copper washer (10) from kit. Slide screw through hole at bottom of fork slider and start into end of damper cartridge.
5. Remove assembly from fork tube holder.
6. Install **new** fork spring (6) into fork tube (15), with dense section of coils toward damper cartridge.
7. Put a shop rag on the floor. Turn the fork assembly upside down. Press the end of the spring against the rag. Compress the spring and tighten the screw to $35 \pm 5 \text{ N}\cdot\text{m}$ ($26 \pm 4 \text{ ft}\cdot\text{lbs}$).
8. With the fork tube upright, clamp fork slider (not the fork tube) into fork tube holder.
9. Coat slider bushing (H) ID and OD with clean fork oil. Slide slider bushing down fork tube (either direction).
10. Slide slider washer (G) down fork tube until it contacts slider bushing (either direction).
11. Coat the ID of the **new** fork oil seal (8) with clean fork oil. Coat the OD of the fork oil seal with Harley-Davidson Seal Grease. With the lettering side facing up, slide fork oil seal down the fork tube until it contacts the slider washer.
12. See Figure 2. Obtain the Fork Seal/Bushing Tool (HD-45305).
 - a. Slide the fork seal installer down the fork tube until it contacts the fork oil seal.
 - b. See Figure 2. Using the tool like a slide hammer, drive fork oil seal (with slider washer and slider bushing) down the fork tube until retaining clip groove is visible in fork slider ID.
 - c. Slide the retaining clip (F) down the fork tube until it contacts the fork oil seal. Install retaining clip in the fork slider groove. Do not expand or stretch retaining clip to install on fork tube or clip may be damaged.
13. Install dust seal (16).
14. Fill the fork tube:
 - a. See Figure 6. Thread extension tool onto end of damper rod.
 - b. With the fork tube compressed, pour Harley-Davidson Type E Fork Oil into the fork tube almost to the top. Pump fork tube ten times to remove air from system.
 - c. Slowly pump the damper rod until resistance is felt through the entire stroke. Then pump ten more times.
 - d. Place the damper rod in the fully bottomed position. Verify fork pipe is bottomed out.
 - e. Remove the extension tool from the end of the damper rod.

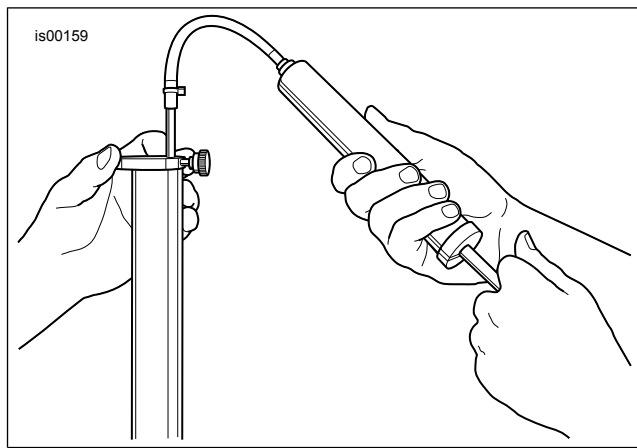

Figure 3. Remove Excess Fork Oil

▲ WARNING

Incorrect amount of fork oil can adversely affect handling and lead to loss of vehicle control, which could result in death or serious injury. (00298a)

15. Adjust the fork oil level, so that it is 120 mm (4.73 in) from the top of the fork tube with the fork tube compressed and the fork spring removed.
 - a. See Figure 3. Obtain the Front Fork Oil Level Gauge (HD-59000B).
 - b. Loosen thumbscrew on metal ring and move it up or down the rod until the bottom of the ring is 120 mm (4.73 in) from the bottom of the rod. Tighten thumbscrew.
 - c. Push the plunger on the cylinder all the way in.
 - d. See Figure 3. Insert rod into top of fork tube until metal ring rests flat on top of fork tube.
 - e. Pull plunger to remove fork oil from fork tube. Observe fork oil through transparent tube to verify that oil is being drawn from fork.
 - f. Remove rod from fork tube. Push plunger into cylinder to eject excess fork oil into suitable container.
16. Install fork spring into the fork tube (15) with the dense end down.

NOTE

Verify that the fork spring is installed with dense section of coils to the bottom.

- g. If necessary, repeat Steps 15(c) through 15(f). Level is correct when no fork oil is observed being drawn through transparent tube.

NOTE

Do not use an air impact wrench to adjust the fork spring compression tool.

17. Thread extension tool onto end of damper rod.

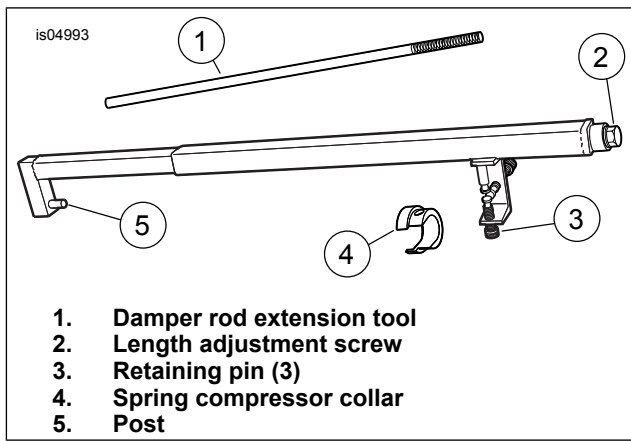

Figure 4. Fork Spring Compressing Tool (HD-45966)

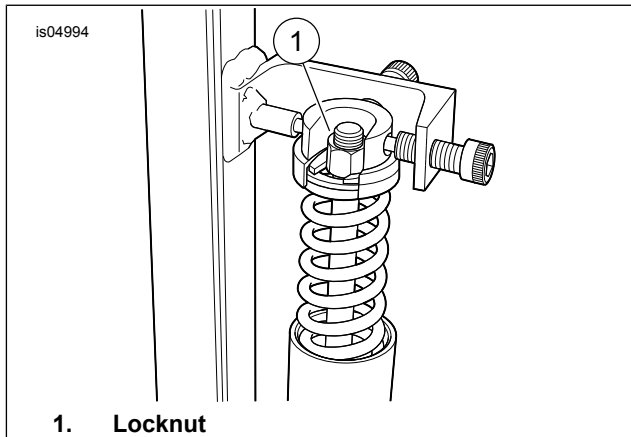

Figure 5. Compress Fork Spring

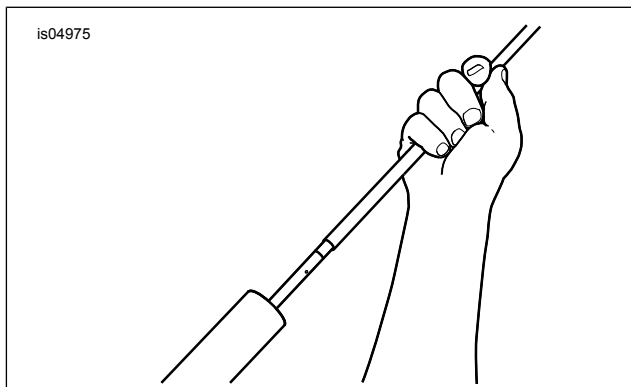

Figure 6. Pump Damper Rod Extension Tool

⚠ WARNING

Wear safety glasses or goggles when removing or installing spring. Spring tension can cause spring, attached components and/or hand tools to fly out which could result in death or serious injury. (00477c)

18. See Figure 4. Install fork spring compressing tool:
 - a. Clamp tool in vise in a vertical position with length adjustment screw (2) upward.
 - b. Place hole at bottom of fork slider over post (5) at bottom end of tool.
 - c. Place flat washer (Item 5, Figure 7), over the damper rod extension tool and on top of spring. Place spring seat (Item 4, Figure 7), concave side up, on top of the flat washer. With the smaller OD upward, place spring compressor collar (item 4, Figure 4) over spring seat and flat washer.

- d. Adjust tool as necessary until three retaining pins (3) engage blind holes in spring compressor collar (4). Turn length adjustment screw counterclockwise to lengthen and clockwise to shorten.
- e. Turn retaining pins as necessary to lock position of spring compressor collar.
- f. Turn length adjustment screw clockwise to compress spring.

19. After a number of turns, pull up on extension tool to raise damper rod. If threaded portion of rod cannot be pulled out of spring, compress spring further. Repeat until threaded portion of rod can be pulled out of spring.
20. Remove extension tool, while holding the damper rod in the extended position.
21. See Figure 7. Install **new** jamnut (3) with non-threaded end over the damper rod first. Thread onto damper rod until it bottoms out on the shoulder.
22. Turn the length adjustment screw at top end of fork spring compressing tool counterclockwise to release tension on fork spring. Loosen retaining pins. Remove spring compressor. Remove fork assembly from tool. Remove tool from vise.
23. Install fork tube holder in vise. Clamp fork tube into fork tube holder.

NOTE

Do NOT over-tighten. O-ring damage can occur.

24. Install **new** O-ring (2) onto **new** fork bolt (1). Thread fork bolt onto threaded end of damper rod until it bottoms. Turn jamnut counterclockwise until it makes firm contact with the fork bolt. Tighten jamnut to 20 ± 2.5 N·m (15 ± 2 ft-lbs).
25. Install **new** fork bolt (1) into fork tube (15). Tighten fork bolt to 55 ± 25 N·m (40.5 ± 18.5 ft-lbs).

Fork Installation

1. See the appropriate service manual. Install the front forks.

⚠ WARNING

After repairing the brake system, test brakes at low speed. If brakes are not operating properly, testing at high speeds can cause loss of control, which could result in death or serious injury. (00289a)

⚠ WARNING

Whenever a wheel is installed and before moving the motorcycle, pump brakes to build brake system pressure. Insufficient pressure can adversely affect brake performance, which could result in death or serious injury. (00284a)

2. See the appropriate service manual. Install front fender, wheel, brakes and any other removed parts.
3. Pump brakes to build system pressure.

SERVICE PARTS

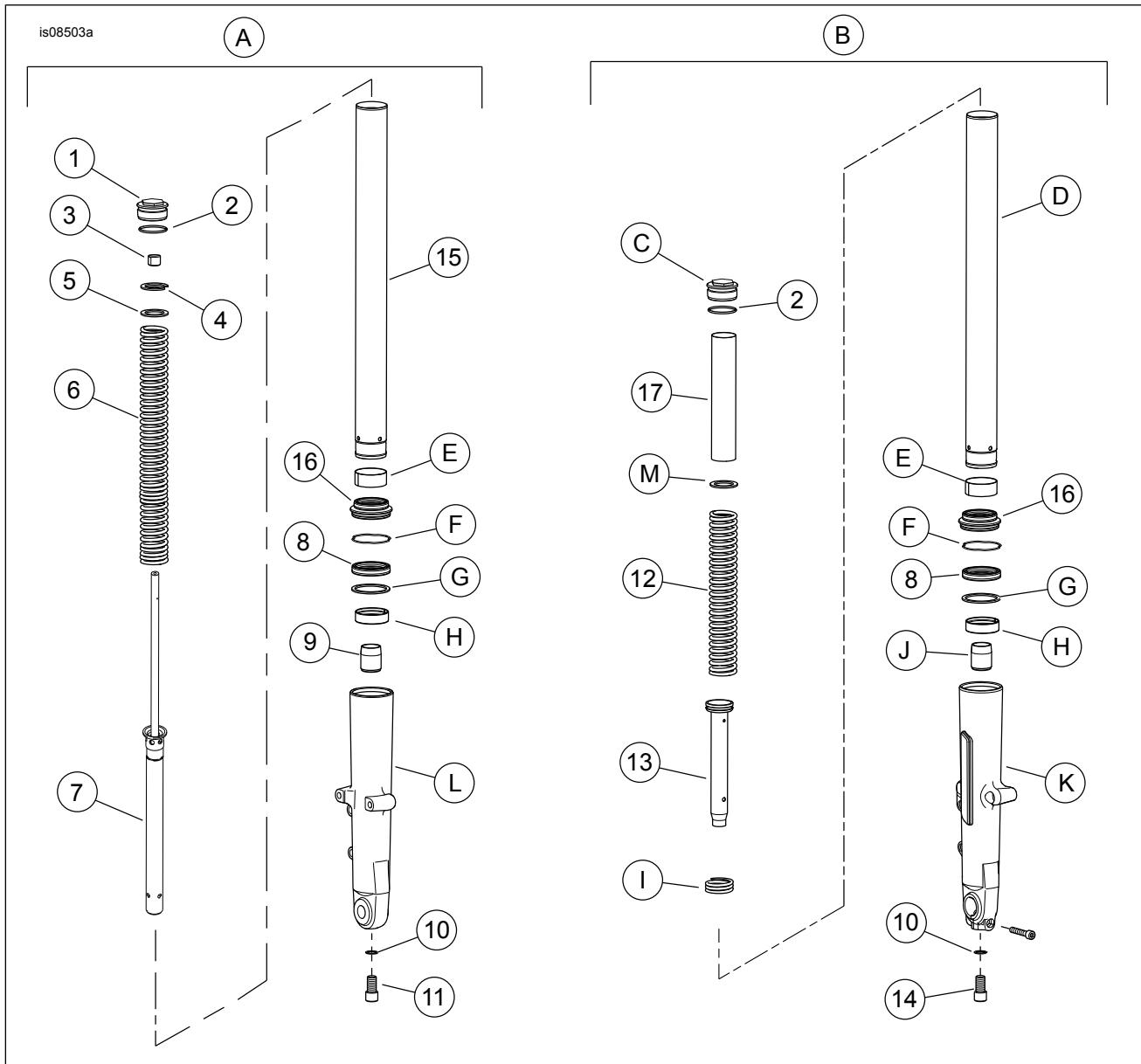

Figure 7. Service Parts: Dyna Cartridge Front Fork Kit

Table 1. Service Parts Table

Item	Description (Quantity)	Part Number
A	Cartridge Fork from Kit (left side)	
B	Stock Fork Assembly, Non-cartridge Fork from Kit (right side)	
Items included in kit:		
1	Fork bolt	Not Sold Separately
2	O-ring (2)	46508-01
3	Jam nut	46262-02
4	Spring seat	46236-02
5	Washer, flat	46237-02
6	Fork spring (approximately 497 mm long)	Not Sold Separately
7	Damper cartridge	Not Sold Separately
8	Fork oil seal (2)	46514-01A
9	Oil lock (with smaller, 12 mm thru-hole)	45500233
10	Washer (2)	46615-06
11	Screw, M10	45500236
12	Fork spring (approximately 407 mm long)	Not Sold Separately
13	Damper tube with piston ring	Not Sold Separately
14	Screw, M14	45500118
15	Fork tube	Not Sold Separately
16	Dust seal	46512-01A

Table 1. Service Parts Table

Item	Description (Quantity)	Part Number
17	Spring collar	Not Sold Separately
Items mentioned in text, but not included in kit:		
C	Fork bolt	
D	Fork tube	
E	Bushing, fork tube (2)	
F	Retaining clip (2)	
G	Slider washer (2)	
H	Slider bushing (2)	
I	Rebound spring	
J	Oil lock (with larger, 14 mm thru-hole)	
K	Fork slider, right	
L	Fork slider, left	
M	Flat Washer	