



INSTRUCTIONS

-J03061

REV. 2006-11-09

VRSC FORK SLIDER DUST COVERS

GENERAL

Kit Number

45153-03, 46319-04

Models

For model fitment information, please see the P&A Retail Catalog or the Parts and Accessories section of www.harley-davidson.com (English only).

WARNING

The rider's safety depends upon the correct installation of this kit. Use the appropriate service manual procedures. If the procedure is not within your capabilities or you do not have the correct tools, have a Harley-Davidson dealer perform the installation. Improper installation of this kit could result in death or serious injury. (00333a)

NOTE

This instruction sheet references Service Manual information. A Service Manual for your model motorcycle is required for this installation and is available from a Harley-Davidson Dealer.

Kit Contents

Table 1. Kit Contents

| Description (Quantity) | Part Number |
|------------------------|---------------------|
| Cover, dust | Not Sold Separately |
| Screw, set | 3321 |

INSTALLATION

1. Remove the right side cover and Maxi-Fuse.
2. Remove the front wheels, brake caliper and front fender according to the applicable procedure in the Service Manual.

WARNING

To prevent accidental vehicle start-up, which could cause death or serious injury, remove maxi-fuse before proceeding. (00251a)

NOTE

When performing the following steps, be extremely careful not to scratch or mar the fork tubes. If a tube becomes scratched/marred, the fork seal may leak and the fork tube will have to be replaced.

3. Remove the fork tubes according to the procedure in the Service Manual.

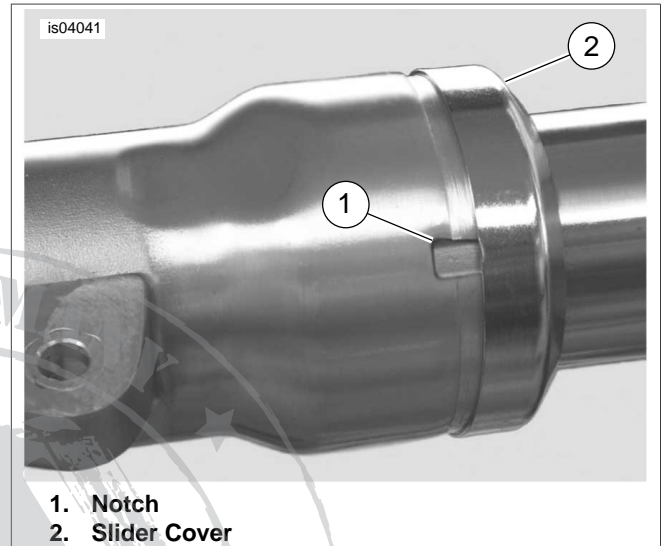

1. Notch
2. Slider Cover

Figure 1. Remove Existing Slider Dust Cover

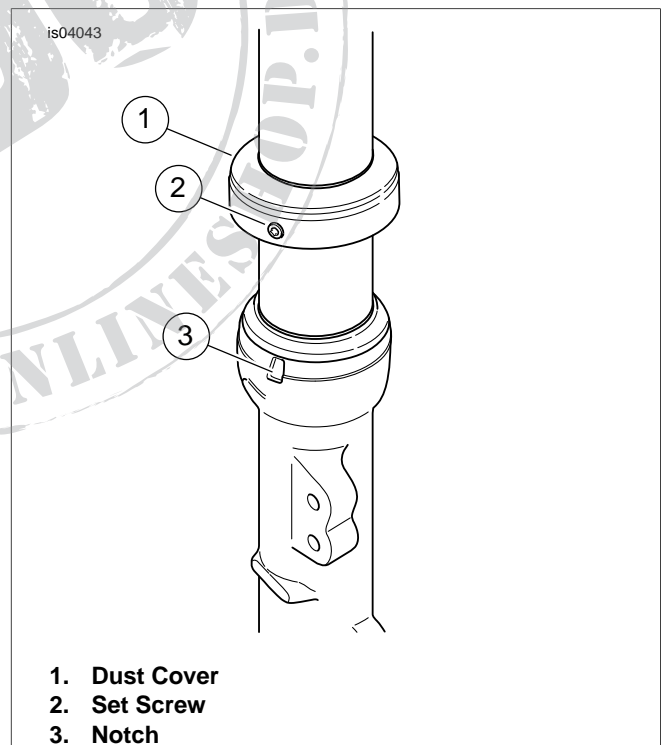

1. Dust Cover
2. Set Screw
3. Notch

Figure 2. Install New Dust Cover

4. See Figure 1. Remove the slider cover from the slider by inserting a brass drift into the notch in the slider and lightly tapping the cover. Remove the cover.
5. See Figure 2. Slide the dust cover (1) over the fork tube, aligning the set screw (2) with the notch (3) in the slider.

Slide the dust cover down until it makes full contact with the slider. Tighten the set screw.

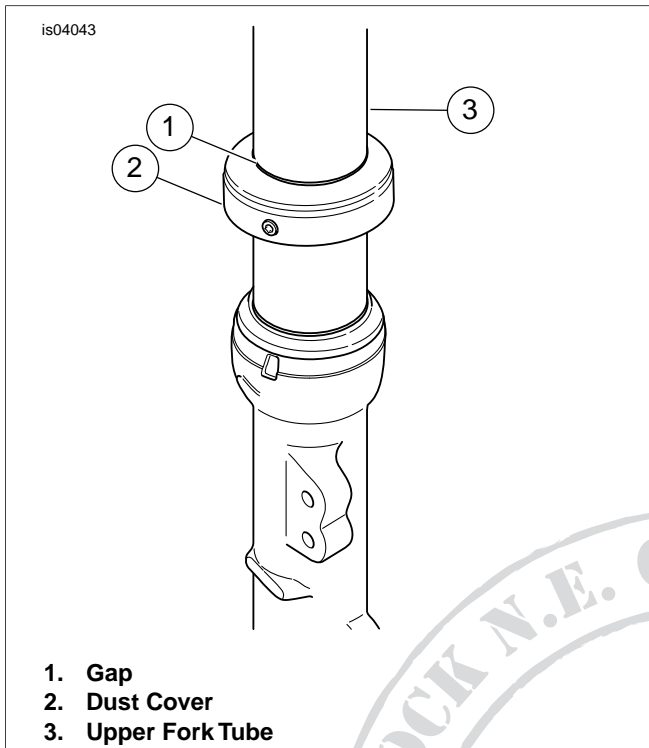

Figure 3. Check Dust Cover-to-Fork Tube Gap

6. See Figure 3. Check for an even gap (1) between the dust cover (2) and the upper fork tube (3).
7. Repeat Steps 3 through 6 for the remaining fork tube.
8. Install the fork tubes according to the procedure in the Service Manual.

⚠ WARNING

Whenever a wheel is installed and before moving the motorcycle, pump brakes to build brake system pressure. Insufficient pressure can adversely affect brake performance, which could result in death or serious injury. (00284a)

⚠ WARNING

After repairing the brake system, test brakes at low speed. If brakes are not operating properly, testing at high speeds can cause loss of control, which could result in death or serious injury. (00289a)

9. Install the front wheels, brake caliper and front fender according to the applicable procedure in the Service Manual.
10. Replace the Maxi-Fuse and right side cover.