



INSTRUCTIONS

-J02519

REV. 2009-03-19

CHROME BRAKE CALIPER HARDWARE KIT

GENERAL

Kit Number

44473-02A

Models

This kit fits all 2000 and later Big Twin and 2000 to 2003 XL model motorcycles.

WARNING

The rider's safety depends upon the correct installation of this kit. Use the appropriate service manual procedures. If the procedure is not within your capabilities or you do not have the correct tools, have a Harley-Davidson dealer perform the installation. Improper installation of this kit could result in death or serious injury. (00333a)

NOTE

This instruction sheet references Service Manual information. A Service Manual for your model motorcycle is required for this installation and is available from a Harley-Davidson Dealer.

Kit Contents

See Figure 2 and Table 1.

There are no Service Parts available with this kit.

INSTALLATION

1. See Figure 1. Remove the existing bleeder screw (1) and bleeder screw cap (2).
2. See Figure 2. Replace the bleeder screw (1) with the screw from the kit. Tighten screw to 80-100 in-lbs (9.0-11.3 Nm).
3. Install bleeder screw cap (B).
4. See Figure 1. Remove the center bridge bolt (4) and replace it with one of the bridge bolts from the kit. Tighten to 28-38 ft-lbs (38.0-51.5 Nm).
5. Repeat step 4 for the two outer bridge bolts (3).
6. Remove one of the pad pins (5).

NOTE

The brake pads must be pushed tight against the anti-rattle spring before the pad pins can be installed.

7. Align the holes in the brake pad and install one of the new pins. The pad pin will give an audible click when installed.
8. Tighten the pad pin to 180-200 in-lbs (20.3-22.6 Nm).
9. Repeat steps 6-8 for the remaining pin.

NOTE

The brake system must be bled after completing the installation of this kit.

10. Follow the Brake Bleeding procedures in the Service Manual for your model motorcycle.

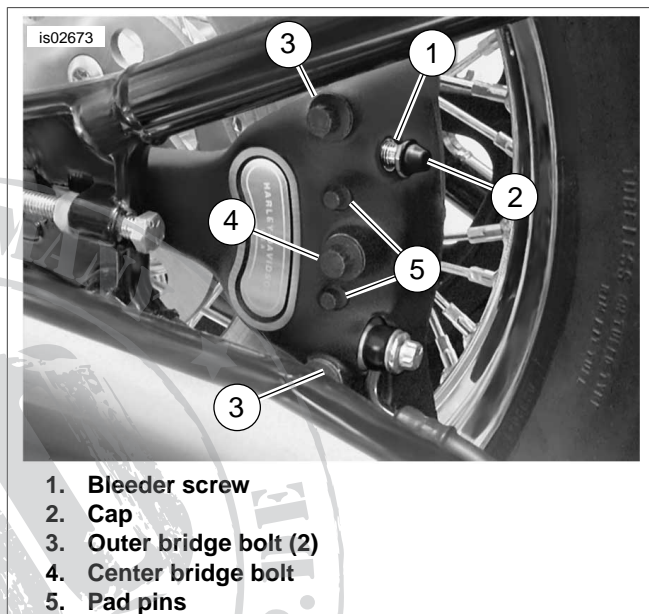

Figure 1. Original Pad Pins and Bleeder Screw on Rear Caliper Brake (Softail Shown)

11. Remove the master cylinder cover. Stand the motorcycle upright so the master cylinder is in a level position.

NOTE

Refer to your model motorcycle's Operator's Manual to determine the correct type of hydraulic brake fluid to be used.

12. Refer to the appropriate Operator's manual to determine the proper type of brake fluid. Fill the master cylinder reservoir until the fluid level is 1/8 inch (3.2 mm) from the top. Use brake fluid from a sealed container.

WARNING

A plugged or covered relief port can cause brake drag or lock-up, which could lead to loss of control, resulting in death or serious injury. (00288a)

13. Verify proper operation of the master cylinder relief port. Actuate the brake hand lever. A slight spurt of fluid will break the fluid surface in the reservoir compartment if all internal components are working properly.
14. Install brake reservoir cover.
15. Depress and hold brake lever to build up hydraulic pressure.
16. Open bleeder valve about 1/2 turn. Brake fluid will flow from bleeder valve through tubing. Close bleeder valve when brake lever has moved 1/2 to 3/4 of its full range of

travel. Allow brake lever to return slowly to its released position.

17. Repeat Steps 13-16 until all air bubbles are purged.
18. Final tighten bleeder valve to 80-100 **in-lbs** (9.0-11.3 Nm). Install bleeder cap. Add brake fluid to master cylinder reservoir until fluid level is about 1/8 inch (3.2 mm) from the top. Final tighten master cylinder reservoir cover screws to 6-8 **in-lbs** (0.7-0.9 Nm).

⚠ WARNING

After repairing the brake system, test brakes at low speed. If brakes are not operating properly, testing at high speeds can cause loss of control, which could result in death or serious injury. (00289a)

19. Test ride the motorcycle. If the brake feels spongy, repeat the bleeding procedure.

SERVICE PARTS

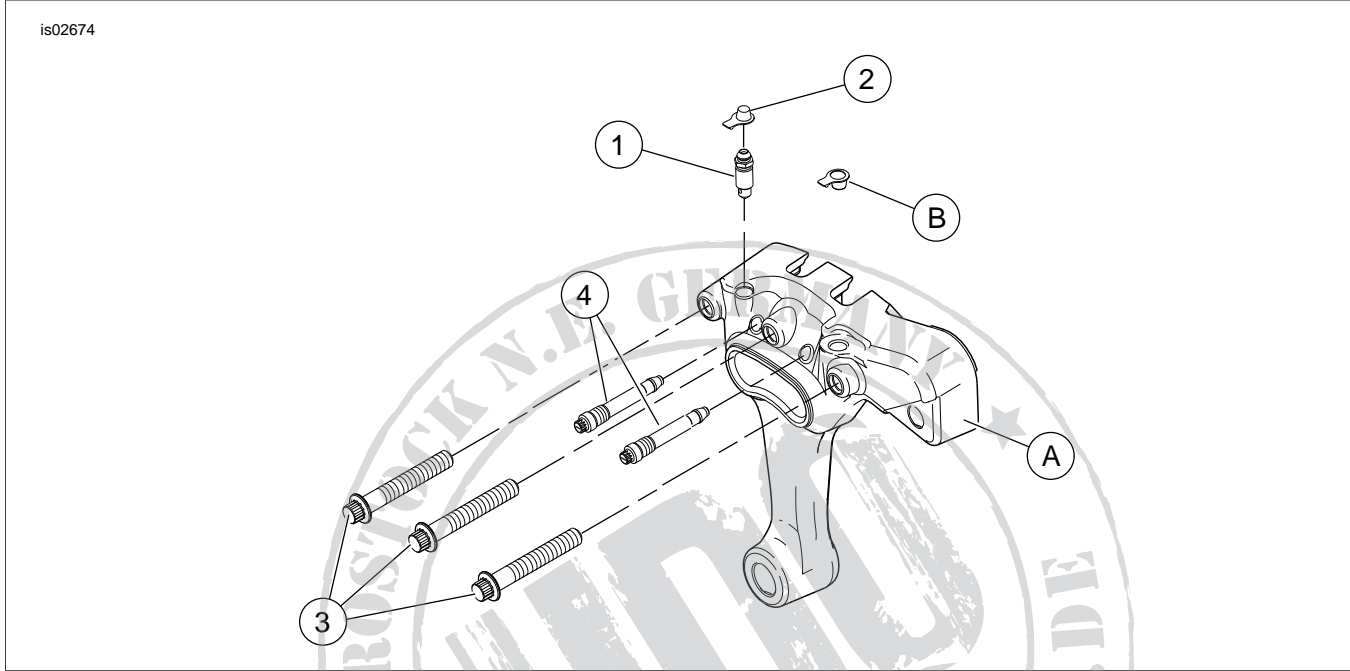

Figure 2. Service Parts: Chrome Brake Caliper Hardware Kit

Table 1. Service Parts Table

Item	Description (Quantity)	Part Number
1	Bleeder screw	Not Sold Separately
2	Bleeder screw cap	Not Sold Separately
3	Bridge bolts (3)	Not Sold Separately
4	Pad pins (2)	Not Sold Separately
Items mentioned in text, but not included in kit:		
A	Stock brake caliper	
B	Banjo bolt hole plug	