



# INSTRUCTIONS

-J00573

REV. 2005-09-28

## CHROME FRONT BRAKE CALIPER(S) KIT

### GENERAL

#### Kit Number

44392-00A and 44395-00A

#### Models

Kit number 44392-00A fits the following models equipped with dual caliper front brakes: 2000 and later Dyna, Softail and Touring models, 2002-2005 VRSC models, and 2000-2003 XL models.

Kit number 44395-00A fits the following models equipped with single caliper front brakes: 2000-2003 XL models and 2000 and later Dyna and Softail models, except FLSTS, FXSTS and FLSTSC.

#### Additional Parts

These kits may require replacement brake pads and pins not included with this kit. The following kits need to be assembled onto each caliper prior to installation.

- Pad Kit (44082-00B)
- Pad Pin Kit (black) (44314-00)
- Pad Pin Kit (44324-02)

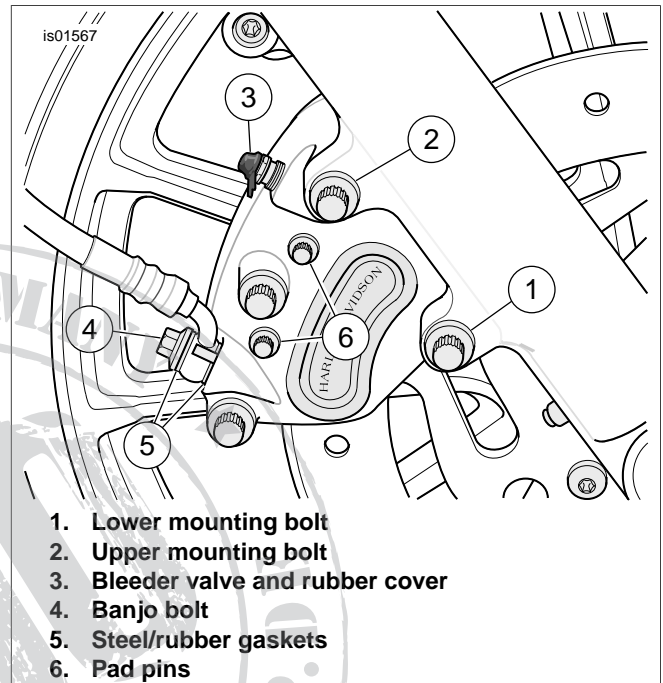

Figure 1. Remove Existing Caliper

### ⚠ WARNING

The rider's safety depends upon the correct installation of this kit. Use the appropriate service manual procedures. If the procedure is not within your capabilities or you do not have the correct tools, have a Harley-Davidson dealer perform the installation. Improper installation of this kit could result in death or serious injury. (00333a)

#### NOTE

This instruction sheet references Service Manual information. A Service Manual for your model motorcycle is required for this installation and is available from a Harley-Davidson Dealer.

#### Kit Contents

See Figure 4 and Table 1.

### INSTALLATION

#### Prepare the Motorcycle for Service

1. For all models except V-Rod: Follow Service Manual instructions to remove seat.

### ⚠ WARNING

To prevent accidental vehicle start-up, which could cause death or serious injury, disconnect negative (-) battery cable before proceeding. (00048a)

2. For all models except V-Rod: Follow Service Manual instructions to remove seat.

**For V-Rod:** Remove the right side cover and remove the maxi-fuse, remove the left side cover and disconnect the negative (-) battery cable.

#### Remove the Existing Caliper

#### NOTE

When performing the following step, place a container under caliper to catch brake fluid that may flow from brake line when removing banjo bolt.

1. See Figure 1. Remove the banjo bolt (4) and both steel/rubber gaskets (5) to detach front brake line from caliper. Retain banjo bolt. Discard gaskets.
2. Loosen but do not remove pad pins (6).

- Remove the upper (long) (2) and lower (short) (1) mounting bolts securing caliper to fork leg. Lift caliper upward to remove from brake disc. Discard caliper and bleeder valve cover but save mounting bolts.
- Note the orientation of the brake pads and remove the two pad pins and the brake pads.
- For dual caliper models:** Repeat for opposite caliper.

### Inspect the Pads and Pins

- Inspect the brake pads. If brake pad is worn to 0.04 in. (1.6 mm) or less above the backing plate, follow the instructions in the Service Manual to replace the pads.
- Inspect pad pins for wear and grooving. If wear is more than 0.015 in. (0.38 mm), replace both pins.
- Inspect brake disc and, if necessary, follow the instructions in the Service Manual to replace brake disc.

### Install the Chrome Caliper(s)

- Obtain left chrome caliper assembly from kit. Remove rubber bleeder valve cover from brake line port (as shipped) and save. Place caliper over brake disc with bleeder valve facing upwards.
- Loosely install upper (long) mounting bolt to top hole in fork leg.
- Install lower (short) mounting bolt into bottom hole of fork leg. Tighten bolt to 28-38 ft-lbs (38.0-51.5 Nm).
- Final tighten upper (long) mounting bolt to 28-38 ft-lbs (38.0-51.5 Nm).
- Install the pre-existing brake pads or, if necessary, follow the instructions in the Service Manual to install new brake pads.
- Install the pad pins through the inner and outer brake pads. Tighten to 180-200 **in-lbs** (20.3-22.6 Nm).

#### NOTE

Do not mix different grades of brake fluid as they are not compatible and could cause equipment damage. Refer to the appropriate Owner's Manual for the correct grade of brake fluid.

- Lubricate two new steel/rubber washers (gaskets) (41731-88A) with the appropriate brake fluid. Connect the brake line to caliper using new steel/rubber washers (gaskets) and banjo bolt. Tighten banjo bolt to 17-22 ft-lbs (23.0-29.8 Nm).
- For dual caliper models:** Repeat for opposite caliper.

### Bleed the Brakes

#### NOTE

Hydraulic brake fluid bladder-type pressure equipment can be used to fill brake master cylinder through the bleeder valve. Remove master cylinder/reservoir cover so that system cannot pressurize. Do not use pressure bleeding equipment when the hydraulic system is sealed with master cylinder reservoir cover and gasket in place.

- See Figure 2. Install end of a length of clear plastic tubing over caliper bleeder valve. Place the other end in a clean container.

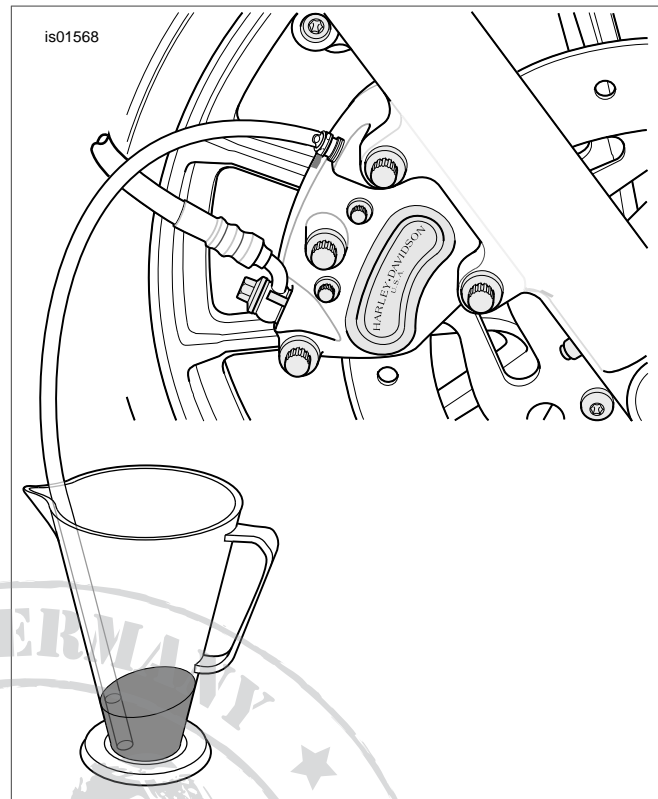

Figure 2. Bleeding Brake

- Stand motorcycle upright and turn the handlebars to level the brake fluid reservoir and remove the cover.

#### NOTE

Do not mix different grades of brake fluid as they are not compatible and could cause equipment damage. Refer to the appropriate Owner's Manual for the correct grade of brake fluid.

#### CAUTION

Direct contact of D.O.T. 5 brake fluid with eyes can cause eye irritation, swelling, and redness. Avoid eye contact. In case of eye contact flush with large amounts of water and get medical attention. Swallowing large amounts of D.O.T. 5 brake fluid can cause digestive discomfort. If swallowed, obtain medical attention. Use in well ventilated area. **KEEP OUT OF REACH OF CHILDREN. (00144a)**

#### CAUTION

D.O.T. 4 brake fluid will damage painted and body panel surfaces it comes in contact with. Always use caution and protect surfaces from spills whenever brake work is performed. Failure to comply can result in cosmetic damage. **(00239b)**

#### CAUTION

Direct contact of D.O.T. 4 brake fluid with eyes can cause irritation. Avoid eye contact. In case of eye contact flush with large amounts of water and get medical attention. Swallowing large amounts of D.O.T. 4 brake fluid can cause digestive discomfort. If swallowed, obtain medical attention. Use in well ventilated area. **KEEP OUT OF REACH OF CHILDREN. (00240a)**

- See Figure 3. Refer to the appropriate Owner's Manual and fill the reservoir with the indicated brake fluid to 1/8 in. (3.2 mm) below the gasket surface.

### **⚠ WARNING**

**Be sure that brake fluid or other lubricants do not contact brake pads or discs. Such contact can adversely affect braking ability, which could cause loss of control, resulting in death or serious injury. (00290a)**

- Depress and hold brake lever to build up hydraulic pressure. Open bleeder valve slowly about 1/2 turn counter-clockwise. Brake fluid with air bubbles will flow from bleeder valve. When brake lever has moved its full range of travel, close bleeder valve (clockwise). Allow brake lever to return slowly to its released position.
- Repeat until all air bubbles are purged and a steady stream of brake fluid flows from the bleeder valve.
- Tighten bleeder valve to 80-100 **in-lbs** (9.0-11.3 Nm). Install rubber bleeder valve cover.
- For dual caliper models: Install tubing on the opposite caliper bleeder valve and repeat procedure.
- Final fill and verify fluid level.

### **⚠ WARNING**

**Be sure the master cylinder relief port is not plugged. A plugged relief port can cause brake drag or lockup and loss of vehicle control, which could result in death or serious injury. (00317a)**

- Verify operation of the master cylinder relief port. Actuate the brake lever with the cover removed. A slight spurt of fluid will break the surface if all internal components are working properly.
- Install gasket and cover on master cylinder. Tighten cover screws to 6-8 **in-lbs** (0.7-0.9 Nm).

### **Return the Motorcycle to Service**

- For all models except V-Rod: Connect negative (-) battery cable to battery.  
For V-Rod: Connect negative battery cable to battery and install left side cover, then install maxi-fuse and right side cover.

- For all models except V-Rod: Follow the instructions in the Service Manual to install the seat.

### **⚠ WARNING**

**After installing seat, pull upward on seat to be sure it is locked in position. While riding, a loose seat can shift causing loss of control, which could result in death or serious injury. (00070b)**

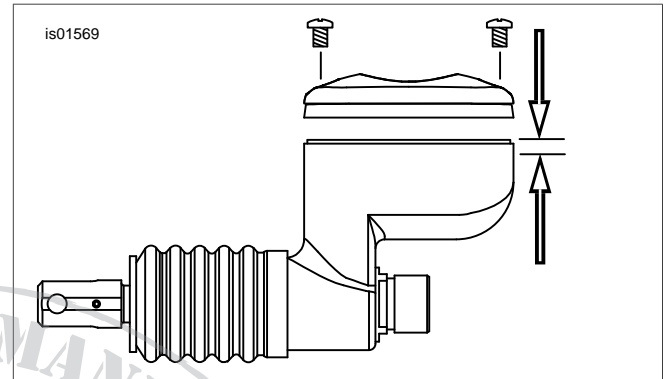

**Figure 3. Reservoir Fill Level 1/8 in. (3.2 mm) Below Gasket Surface**

### **Test the Brakes**

### **⚠ WARNING**

**After repairing the brake system, test brakes at low speed. If brakes are not operating properly, testing at high speeds can cause loss of control, which could result in death or serious injury. (00289a)**

- Turn ignition switch ON.
- Pump brake hand lever to verify operation of the brake lamp.
- Test ride the motorcycle. If the brakes feel spongy, bleed the brake system again.

### **NOTE**

*Avoid making hard stops for the first 100 miles (160 km). This allows the new pads to become conditioned to the brake discs.*

## SERVICE PARTS

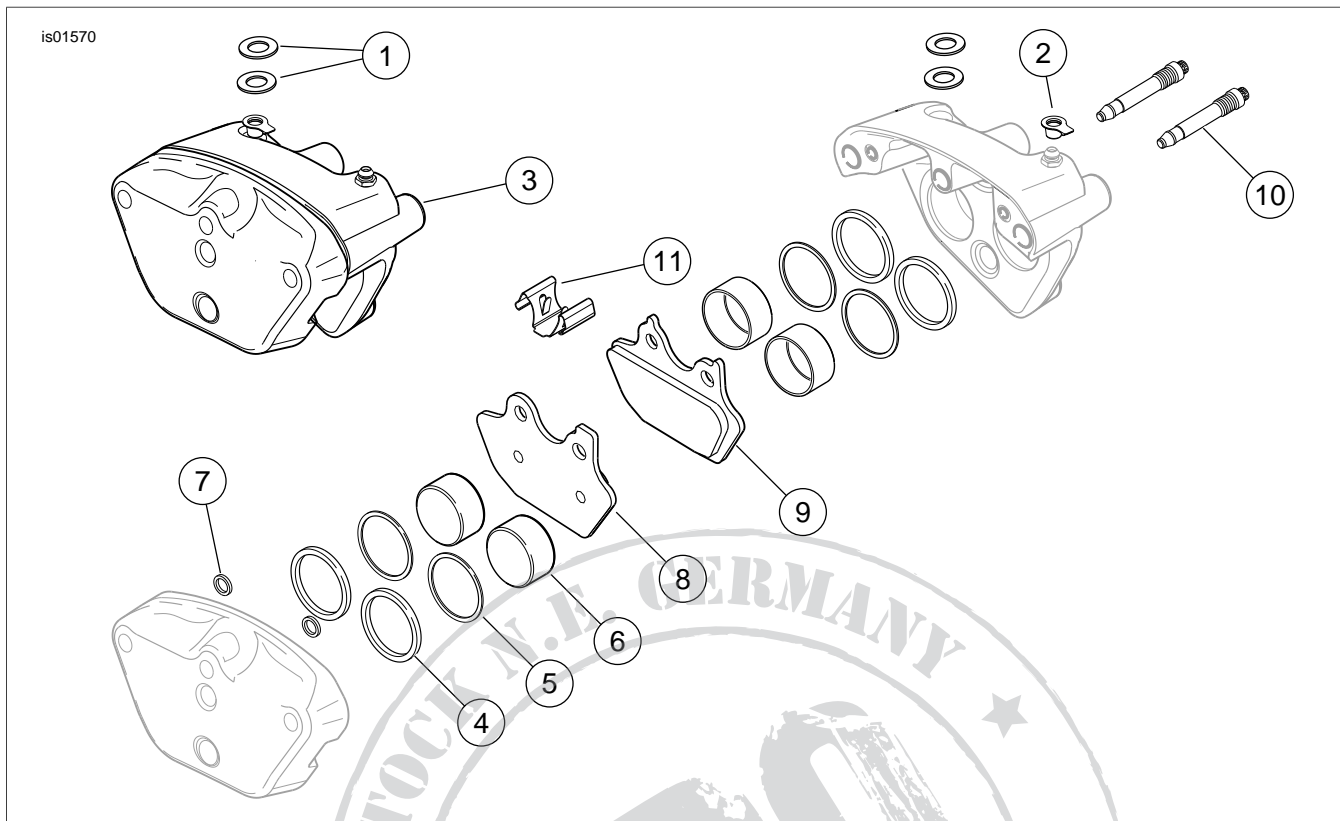

**Figure 4. Service Parts for Chrome Front Brake Caliper(s) Kit**

**Table 1. Service Parts Table**

Kit	Item	Description (Quantity)	Part Number
Kit 44392-00A Chrome Front Brake Caliper Kit (Dual)	1	Steel/rubber gasket, brakeline (4)	41731-01
	2	Cap, bleeder (2)	44147-87A
	3	Chrome caliper assembly (right side)*	Not Sold Separately
	12	Chrome caliper assembly (left side, not shown)*	Not Sold Separately
Kit 44395-00A Chrome Front Brake Caliper Kit (Single)	1	Steel/rubber gasket, brakeline (2)	41731-01
	2	Cap, bleeder	44147-87A
	12	Chrome caliper assembly (left side, not shown)*	Not Sold Separately
Kit 44313-01 Piston Kit**	4	Square seal (4)**	44329-01
	5	Piston, wiper (4)	44330-01
	6	Piston (4)	44335-01
	7	Crossover O-ring (2)**	44336-00
Kit 44082-00A Pad Kit	8	Brake pad and holder, inner	Not Sold Separately
	9	Brake pad and holder, outer	Not Sold Separately
Kit 44314-00 (black) Kit 44324-02 (silver) Pad Pin Kit	10	Pad pin (2)	Not Sold Separately
Kit 44337-00B Anti-Rattle Spring Kit	7	Crossover O-ring (2)**	44336-00
	11	Anti-rattle spring	Not Sold Separately

**Notes**

\* Chrome caliper is an assembly of caliper halves, pistons, seals and wipers, bridge bolts, bleeder valve, rubber bumper, crossover O-rings and anti-rattle spring.

\*\* Piston wipers, seals and crossover O-rings are only available in a separate Seal Kit (44315-00).