



INSTRUCTIONS

-J00113

REV. 2004-09-03

HEAD BOLT COVERS

GENERAL

Kit Number

43884-96, 43885-96, 43890-93, 43911-95

Models

These kits fit 1985 and later Evolution® 1340 models, 1987 and later XL® models, 1999 and later Twin Cam 88® models.

Kit Contents

See Table 1 and Table 2.

Table 1. Kit Number 43890-93

| Description (Quantity) | Part Number |
|------------------------|---------------------|
| Head bolt covers (4) | Not Sold Separately |
| Set screws (4) | 3231B |
| Allen wrench | Not Sold Separately |

Table 2. Kit Numbers 43911-95, 43884-96, 43885-96

| Description (Quantity) | Part Number |
|----------------------------------|---------------------|
| Head bolt covers, right-hand (2) | Not Sold Separately |
| Head bolt covers, left-hand (2) | Not Sold Separately |
| Set screws (4) | 3231B |
| Allen wrench | Not Sold Separately |

NOTE

A Service Manual for your model motorcycle is available from a Harley-Davidson Dealer.

INSTALLATION

WARNING

Perform this installation when the engine is cool. Working on or near the exhaust system when the engine is hot could result in severe burns. (00311a)

NOTE

For ease of installation, start set screw by hand prior to placement of bolt covers. Mild thread sealant can be used on set screw to assure easy removal.

1. Remove spark plugs. Use applicable Service Manual procedure.
2. See Figure 1. Install head bolt covers (1), on head bolts (3). Tighten using set screw (2) and Allen wrench included with kit. To prevent set screws from falling into the spark plug holes, start threading the set screws into the covers before placing them over the head bolts. Position cover on head bolt so that when spark plug is re-installed, set screw is hidden from view but accessible to an Allen wrench. Do not tighten set screws on high points of bolts.
3. **For Kit Numbers 43911-95, 43884-96 and 43885-96:** The logo faces outward, to the side of the bike. To assure proper cover position and alignment, the set screw for the right-hand bolt cover on each cylinder head should be at the ten o'clock position, and for the left-hand bolt cover the set screws should be at the two o'clock position.
4. Re-install spark plugs.
5. Re-tighten set screws after motor has operated at full operating temperature and then cooled.

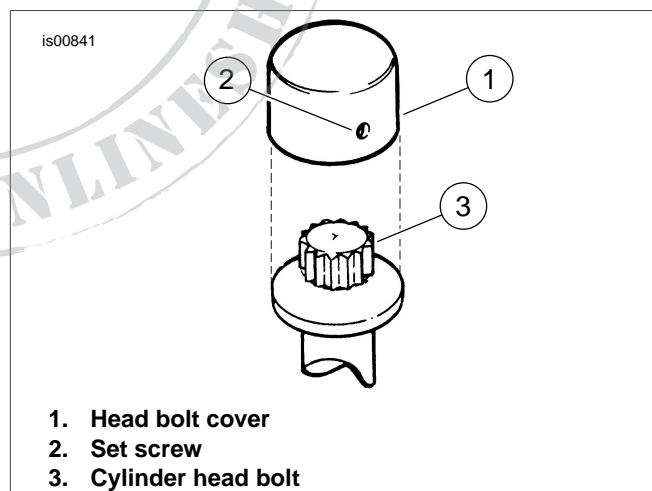

Figure 1. Head Bolt Cover Installation