



INSTRUCTIONS

-J01892

REV. 2007-07-24

HEADBOLT COVER KIT

GENERAL

Kit Number

43858-00

Models

For model fitment information, please see the P&A Retail Catalog or the Parts and Accessories section of www.harley-davidson.com (English only).

Kit Contents

See Figure 2 and Table 1.

INSTALLATION

NOTE

A Service Manual for your model motorcycle is available from a Harley-Davidson Dealer.

NOTE

Let engine cool down completely before installing this kit.

Install Front Cover

NOTE

The front and rear headbolt covers are different. The front headbolt cover has "front" cast on the inside surface; the rear headbolt cover has "rear" cast on the inside surface.

1. Disconnect spark plug boot from front spark plug.
2. See Figure 2. Install mounts (3) to headbolts using setscrews and tighten securely.
3. Place the headbolt cover (1) marked "front" on the head-over spark plug and mounts. Insert cap screw (4) through top of cover, align with threaded hole in top of cover mount and tighten securely. Repeat for remaining cover screw.

NOTE

On Dyna Models, perform Step 4 prior to installing the front spark plug boot. For all other models, proceed to Step 5.

4. For Dyna Models:

- a. Cut and remove the plastic tie wrap retaining the front cylinder spark plug wire to the horn support bracket. Be sure to clear the tie wrap "Christmas tree" completely out of the holes in the horn support bracket.
- b. See Figure 1. Install the cable shield (1) onto the front cylinder spark plug wire. Route plug wire with shield under horn support bracket, then assemble cable straps (2) over plug wire, lacing end of cable strap through horn support bracket, but do not pull tight at this time. Position shield so it protects wire in area of horn support bracket.

5. Connect the front spark plug wire boot to plug and align boot.

6. Pull cable straps tight and snip off excess.

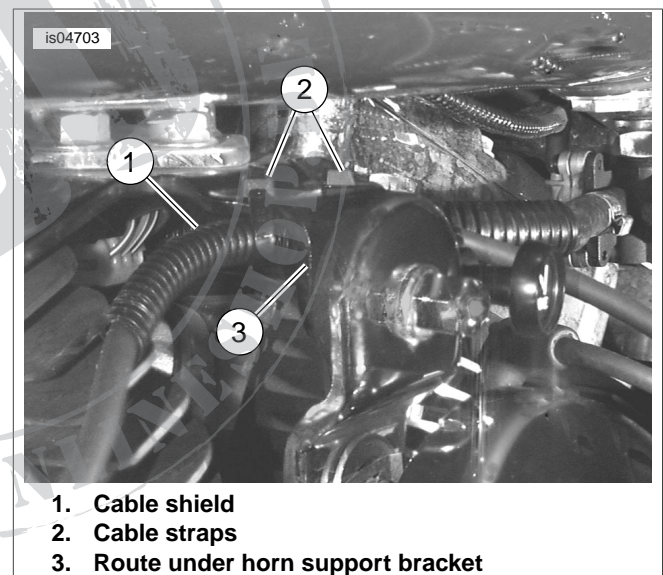

Figure 1. Conduit and Front Plug Wire Routing (Dyna Only)

Install Rear Cover

1. Disconnect spark plug boot from rear spark plug.
2. See Figure 2. Install mounts (3) to head bolts using setscrews and tighten securely.
3. Place the headbolt cover (2) marked "rear" on the head over spark plug and mounts (installed in Step 2). Insert cap screw through top of cover, align with threaded hole in top of cover mount and tighten securely. Repeat for remaining cover screw.
4. Connect the rear spark plug wire boot to the plug.

SERVICE PARTS

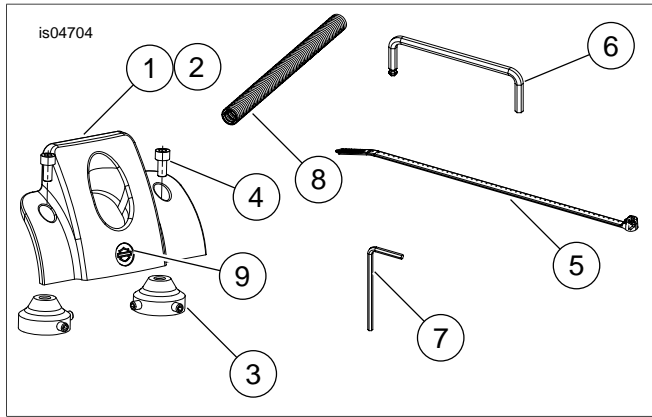

Figure 2. Service Parts: Headbolt Cover Kit

Table 1. Service Parts: Seat Hardware Kit

Item	Description (Quantity)	Part Number
1	Cover, headbolts (front)	43869-00
2	Cover, headbolts (rear)	43870-00
3	Mounts (4)	43874-00
4	Cap screw, socket head 10-32 x 3/8 (4)	Not Sold Separately
5	Cable strap (2)	10006
6	Wrench, hex key (5/32 inch)	94794-00
7	Wrench, hex key (3/32 inch)	Not Sold Separately
8	Cable shield, split flex	63641-00
9	Logo, bar and shield	13599-00

