



INSTRUCTIONS

-J05314

2012-10-18

VAPOR FRONT WHEEL

GENERAL

▲ WARNING

Install only wheels and installation kits approved for your model motorcycle. Contact a Harley-Davidson dealer to verify fitment. Mismatching wheels and installation kits or installing wheels not approved for your model can cause loss of control, which could result in death or serious injury. (00610c)

Kit Number

43300067

Models

For model fitment information, see the P&A Catalog or the Parts and Accessories section of www.harley-davidson.com.

Kit Contents

See the Service Parts section for kit contents.

Additional Parts Required

NOTE

Accessory hub caps are not compatible with this wheel.

This kit includes the custom wheel only.

Proper installation of this kit requires the separate purchase of the following parts which are available at a Harley-Davidson dealer:

- Wheel Installation Kit (See Table 2 and Table 3.)
- 5 Brake Disc/Hub Cap Screws (3762M) and 5 washers (6966M) or one chrome screw kit (91800029)
- Wheel Bearing Remover and Installer (94134-09)

The following Harley-Davidson Genuine Motor Accessories are recommended for proper maintenance and cleaning:

- Harley® Bright™ Chrome Cleaner (94683-99)
- Harley® Glaze™ Polish and Sealant (99701-84)
- Harley® Wheel and Spoke Brush (43078-99)
- Harley-Davidson® Wheel and Tire Cleaner (94658-98)
- Harley® Preserve™ Bare Aluminum Protectant (99845-07)

▲ WARNING

The rider's safety depends upon the correct installation of this kit. Use the appropriate service manual procedures. If the procedure is not within your capabilities or you do not have the correct tools, have a Harley-Davidson dealer perform the installation. Improper installation of this kit could result in death or serious injury. (00333a)

NOTE

This instruction sheet references service manual information. A service manual for your model motorcycle is required for this installation and is available from a Harley-Davidson dealer.

INSTALLATION

NOTE

Install pull thru valve stem (40999-87) included in the installation kit. Discard all other valve stems.

1. Remove existing front wheel assembly. Save axle, axle nut, brake disc and wheel spacers for kit installation. Refer to the service manual.

NOTE

The shim(s) provided in the installation kit are not required for this wheel kit and can be discarded.

2. See Figure 1. Install valve stem assembly (N) on wheel. Refer to service manual.

NOTICE

Do not re-use brake disc/rotor screws. Re-using these screws can result in torque loss and damage to brake components. (00319c)

NOTE

The brake disc side of the wheel is the primary bearing side of the wheel.

3. Assemble wheel installation kit components and brake disc to wheel, using the appropriate service parts table. Refer to service manual.
4. Install primary bearing first following the instructions in the service manual and using a WHEEL BEARING REMOVER/INSTALLER.
5. Install stock wheel spacers.
6. Install front wheel (1), stock axle and stock spacers to motorcycle. See service manual.

MAINTENANCE AND CLEANING

1. Clean heavily-soiled wheel surfaces using Harley-Davidson Wheel and Tire Cleaner applied with the Harley Wheel and Spoke Brush.
2. After cleaning and polishing, seal the finish with a good quality sealer, such as Harley Glaze Polish and Sealant.

SERVICE PARTS

is06985

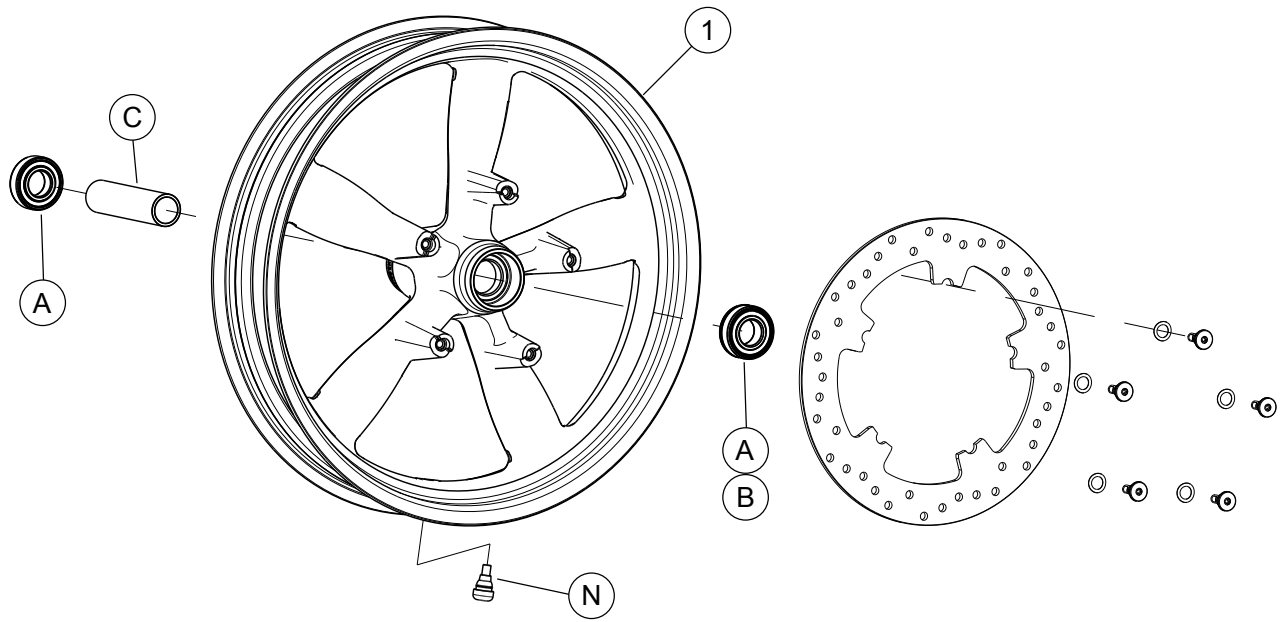

Figure 1. Service Parts: Vapor Front Wheel

Table 1. Service Parts and Wheel Kit Contents

Kit	Item	Description (Quantity)	Part Number
43300067	1	Wheel	Not Sold Separately

Table 2. FRONT 25 mm Bearing Wheel Installation Kit (43851-11A)

FRONT 25 mm Bearing Wheel Installation Kit (43851-11A)		ITEM (Quantity Used and Description)								
Fitment	Wheel Size	A	C	G	H	J	L	M	N	
2007 and later FLSTC, FLSTN and FLS (non-ABS)	16 x 3.0 in	2	1	0	1	1	*	*	*	
2008 and later FXDF	16 x 3.0 in	2	1	0	0	0	*	*	*	
2007 and later FLSTF and FLSTFB (non-ABS)	17 x 3.5 in	2	1	0	0	0	*	*	*	
2008 and later FLSTF and FLSTFB (non-ABS)	18 x 3.5 in	2	1	0	0	0	*	*	*	
2008 and later FXDF; 2012 and later FLD	18 x 3.5 in	2	1	0	0	0	*	*	*	
2007 and later FXS, FXST/B/C (non-ABS); 2008 and later FXDWG***	21 x 2.15 in	2	1	0	0	1	*	*	*	
2007 FXSTD***	21 x 2.15 in	2	1	1	0	1	*	*	*	
Installation kits are designed to work with many different wheel styles and fitments. Contact a Harley-Davidson dealer to verify that the wheel and installation kits are both designed and approved for the motorcycle they are being installed on.		A	Bearing, regular (2)		9276					
NOTES:		C	Axle sleeve		41349-07					
* See NOTE above valve installation step in INSTALLATION to determine which valve stem to use for your particular kit. Discard other valve stem(s).		G	Spacer, axle		41504-07					
** Bearing shim installed under the primary bearing.		H	Spacer, axle		41695-07					
*** The left side of the wheel is the primary bearing side for this fitment.		J	Bearing shim**		43315-07					
		L	Valve stem, short		43157-83A					
		M	Valve stem, long		43206-01					
		N	Valve stem, pull-thru		40999-87					

Table 3. FRONT 25 mm Bearing ABS Wheel Installation Kit (42400010)

FRONT 25 mm Bearing ABS Wheel Installation Kit (42400010)		ITEM (Quantity Used and Description)								
Fitment	Wheel Size	A	B	C	G	J	K	L	M	N
2011 and later FLSTC, FLSTN and FLS with ABS	16 x 3.0 in	1	1	1	1	0	1	*	*	*
2012 and later FXDF with ABS	16 x 3.0 in	1	1	1	0	0	0	*	*	*
2011 and later FLSTF and FLSTFB with ABS	17 x 3.5 in	1	1	1	0	0	0	*	*	*
2011 and later FLSTF and FLSTFB with ABS	18 x 3.5 in	1	1	1	0	0	0	*	*	*
2012 and later FXDF and FLD with ABS	18 x 3.5 in	1	1	1	0	0	0	*	*	*
2011 and later FXS, FXST and 2012 and later FXDWG with ABS	21 x 2.15 in	1	1	1	0	0	1	*	*	*

Table 3. FRONT 25 mm Bearing ABS Wheel Installation Kit (42400010)

FRONT 25 mm Bearing ABS Wheel Installation Kit (42400010)		ITEM (Quantity Used and Description)								
Fitment	Wheel Size	A	B	C	G	J	K	L	M	N
Installation kits are designed to work with many different wheel styles and fitments. Contact a Harley-Davidson dealer to verify that the wheel and installation kits are both designed and approved for the motorcycle they are being installed on. NOTES: * See NOTE above valve installation step in INSTALLATION to determine which valve stem to use for your particular kit. Discard other valve stem(s). ** Red side of bearing must be installed toward the wheel. The ABS bearing is the primary bearing. *** Bearing shim installed under the primary bearing.		A	Bearing, regular							9276A
		B	Bearing, ABS**							9252
		C	Axle sleeve							41349-07
		G	Spacer							41695-07
		J	Bearing shim***							41448-08
		K	Bearing shim***							43315-07
		L	Valve stem, short							43157-83A
		M	Valve stem, long							43206-01
		N	Valve stem, pull-thru							40999-87