



INSTRUCTIONS

-J05273

REV. 2010-09-30

FRONT FAT-X WHEEL

GENERAL

WARNING

Install only wheels and installation kits approved for your model motorcycle. Contact a Harley-Davidson dealer to verify fitment. Mismatching wheels and installation kits or installing wheels not approved for your model can cause loss of control, which could result in death or serious injury. (00610c)

Kit Numbers

43300045

Models

For model fitment information, see the P&A Retail Catalog or the Parts and Accessories section of www.harley-davidson.com (English only).

NOTE

Accessory hub caps are not compatible with this wheel.

Kit Contents

This kit includes the custom wheel only.

Additional Parts Required

Proper installation of this kit requires the separate purchase of the following parts which are available at a Harley-Davidson dealer:

- Wheel Installation Kit (See Table 3.)
- Brake Disc Screws (See Figure 1 and Table 1.)
- Wheel Bearing Remover and Installer (94134-09)

The following Harley-Davidson Genuine Motor Accessories are recommended for proper maintenance and cleaning:

- Harley® Bright™ Chrome Cleaner (94683-99)
- Harley® Glaze™ Polish and Sealant (99701-84)
- Harley® Wheel and Spoke Brush (43078-99)
- Harley-Davidson® Wheel and Tire Cleaner (94658-98)
- Harley® Preserve™ Bare Aluminum Protectant (99845-07)

WARNING

The rider's safety depends upon the correct installation of this kit. Use the appropriate service manual procedures. If the procedure is not within your capabilities or you do not have the correct tools, have a Harley-Davidson dealer perform the installation. Improper installation of this kit could result in death or serious injury. (00333a)

NOTE

This instruction sheet references service manual information. A service manual for your model motorcycle is required for this installation and is available from a Harley-Davidson dealer.

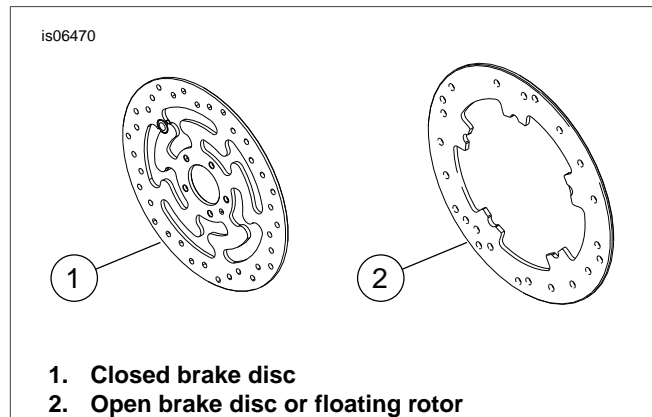

Figure 1. Front Brake Disc Styles

Table 1. Front Disc Hardware Fitment

Brake Disc	Hardware
Closed disc	5 Stock disc screws (3655A)
	Chrome screw kit (46646-05) includes 5 screws
Open disc	5 Stock disc screws (3762M) and 5 disc washers (6966M)

NOTE: Models equipped with dual front brakes and models being equipped with a wheel with dual brake mounting surfaces require twice as many screws/washers (10 total screws or 2 chrome screw kits if available).

INSTALLATION

1. Remove existing front wheel assembly. Save axle, axle nut, brake disc and wheel spacers for kit installation. Refer to FRONT WHEEL in service manual.

NOTICE

Do not re-use brake disc/rotor screws. Re-using these screws can result in torque loss and damage to brake components. (00319c)

NOTE

Install pull thru valve stem (40999-87) included in the installation kit. Discard all other valve stems.

2. See Figure 2. Install valve stem assembly (N) on wheel. Refer to TIRES in service manual.

NOTES

Install the primary bearing first using appropriate service manual and WHEEL BEARING REMOVER/INSTALLER.

The brake mounting surfaces on the left side of the wheel indicate the primary bearing side.

3. Assemble the wheel installation kit components and brake disc(s) to wheel, using the appropriate service parts table. Refer to FRONT WHEEL in service manual.
4. Install previously removed wheel spacers. Refer to FRONT WHEEL in service manual.
5. Install front wheel (1), stock axle and stock axle nut. Refer to FRONT WHEEL in service manual.

MAINTENANCE AND CLEANING

Chrome parts must be maintained regularly to keep their original shine and luster.

1. Clean heavily-soiled wheel surfaces using Harley-Davidson Wheel and Tire Cleaner, applied with Harley Wheel and Spoke Brush.
2. Thoroughly clean chrome with a good quality chrome cleaner, such as Harley Bright Chrome Cleaner.
3. After cleaning and polishing, seal the finish with a good quality sealer, such as Harley Glaze Polish and Sealant.

SERVICE PARTS

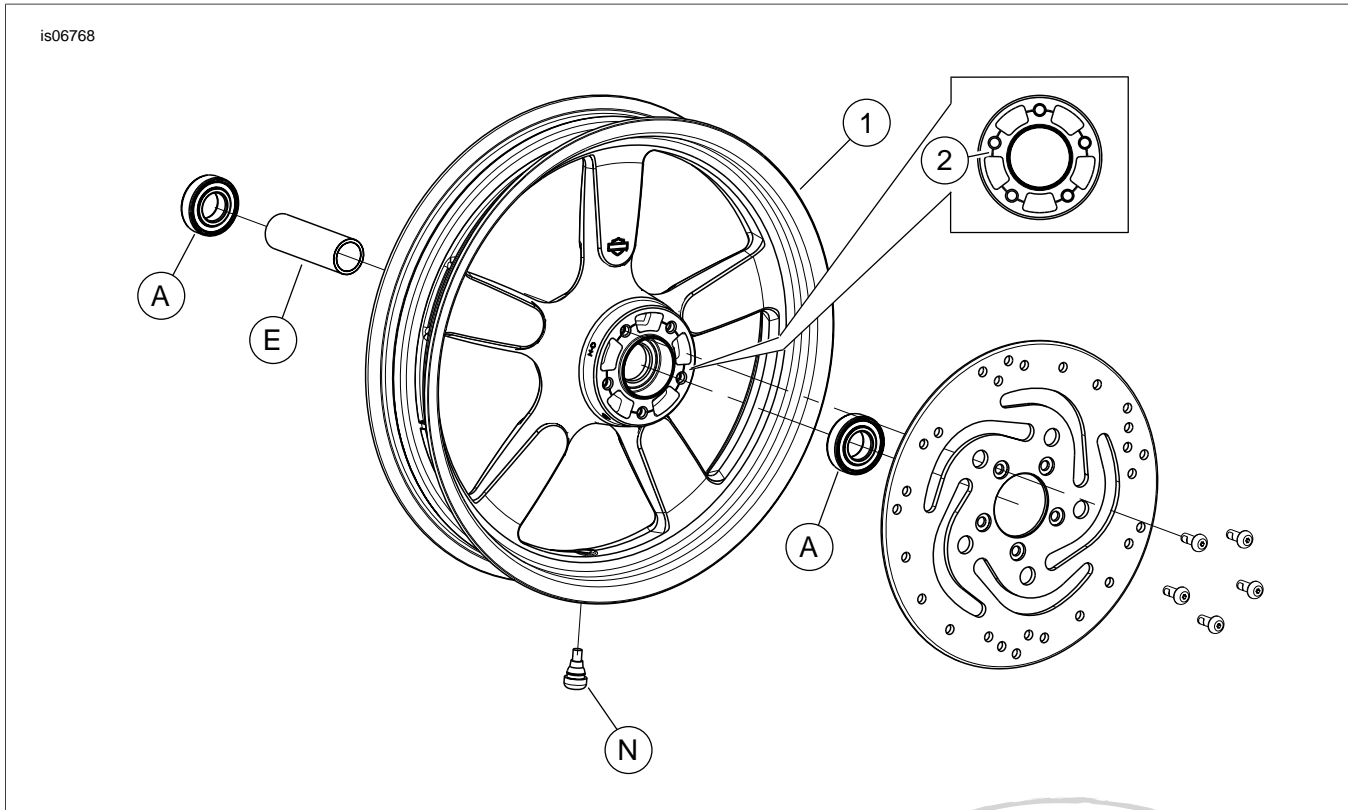

Figure 2. Service Parts: Front Fat-X Wheel

Table 2. Service Parts and Wheel Kit Contents

Kit	Item	Description (Quantity)	Part Number
43300045	1	Wheel	Not Sold Separately
		Visual indicator mentioned in text:	
	2	Machined groove (all wheels)	

Table 3. FRONT 25 mm Bearing Wheel Installation Kit (41452-08C)

FRONT 25 mm Bearing Wheel Installation Kit (41452-08C)		ITEM (Quantity Used and Description)								
Fitment	Wheel Size	A	C	D	E	J	K	L	M	N
2010 and later XL1200X; 2011 and later XL1200C	16 x 3.0 in	2	0	0	1	0	0	*	*	*
2008 and later FXCW and FXCWC (non-ABS)	19 x 2.5 in	2	1	0	0	1	0	*	*	*

Table 3. FRONT 25 mm Bearing Wheel Installation Kit (41452-08C)

FRONT 25 mm Bearing Wheel Installation Kit (41452-08C)		ITEM (Quantity Used and Description)									
Fitment	Wheel Size	A	C	D	E	J	K	L	M	N	
2008 and later FXCW and FXCWC (non-ABS)	19 x 2.15 in	2	1	0	0	0	0	*	*	*	
2008 and later XL (except XL1200X and 2011 and later XL883L)	19 x 2.5 in	2	0	1	0	0	1	*	*	*	
2008 and later XL (except XL1200X and 2011 and later XL883L)	21 x 2.15 in	2	0	1	0	0	1	*	*	*	
Installation kits are designed to work with many different wheel styles and fitments. Contact a Harley-Davidson dealer to verify that the wheel and installation kits are both designed and approved for the motorcycle they are being installed on. NOTES: * See <i>NOTE</i> above valve installation step in INSTALLATION to determine which valve stem to use for your particular kit. Discard other valve stem(s). ** Bearing shim installed under the primary bearing.		A	Bearing, regular (2)					9276			
		C	Axle sleeve					41548-08			
		D	Axle sleeve					43906-08			
		E	Axle sleeve					11888			
		J	Bearing shim**					41448-08			
		K	Bearing shim**					43315-07			
		L	Valve stem, short					43157-83A			
		M	Valve stem, long					43206-01			
		N	Valve stem, pull thru					40999-87			

