



INSTRUCTIONS

-J02670

REV. 2008-06-26

REAR PAD KIT

GENERAL

Kit Number

42836-04A, 42029-07

Models

For model fitment information, see the P&A Retail Catalog or the Parts and Accessories section of www.harley-davidson.com (English only).

Additional Parts Required

WARNING

The rider's safety depends upon the correct installation of this kit. Use the appropriate service manual procedures. If the procedure is not within your capabilities or you do not have the correct tools, have a Harley-Davidson dealer perform the installation. Improper installation of this kit could result in death or serious injury. (00333a)

Fresh, uncontaminated brake fluid is required for installation of this kit. See the service manual for the correct type of brake fluid.

NOTE

This instruction sheet references service manual information. A service manual for your model motorcycle is required for this installation and is available from a Harley-Davidson dealer.

Kit Contents

Table 1. Kit Contents

Qty	Description	Part Number
2	Rear pad	Not Sold Separately
1	Retainer clip	Not Sold Separately

There are no Service Parts available with this kit.

BRAKE PADS

WARNING

Always replace brake pads in complete sets for correct and safe brake operation. Improper brake operation could result in death or serious injury. (00111a)

NOTES

See Figure 1. Replace brake pads (3) if brake pad friction material on either the front or rear caliper is worn to 0.04 in (1.0 mm) or less above the backing plate (4).

When checking the brake pads and discs, inspect the brake lines for correct routing and any signs of damage.

-J02670

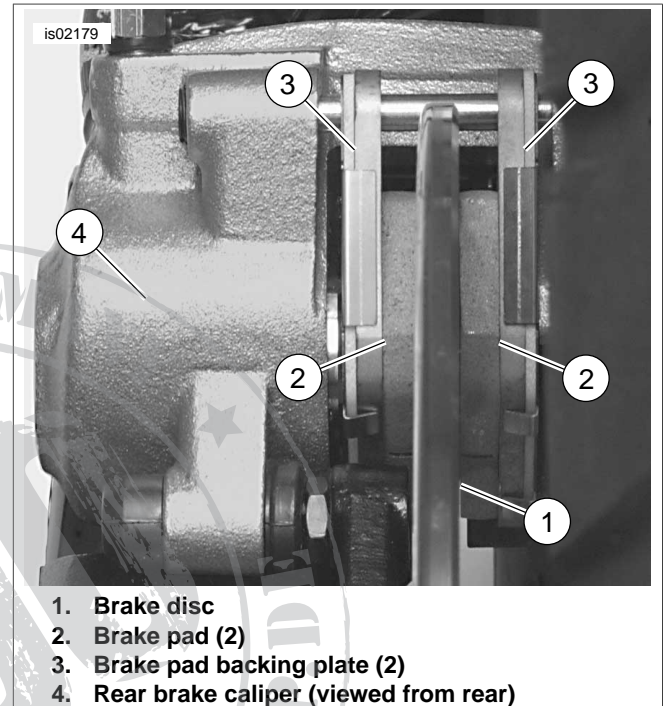

1. Brake disc
2. Brake pad (2)
3. Brake pad backing plate (2)
4. Rear brake caliper (viewed from rear)

Figure 1. Brake Pad Inspection

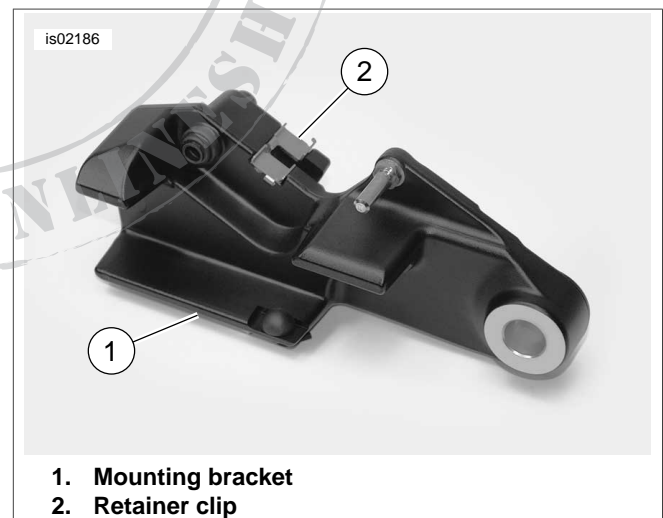

1. Mounting bracket
2. Retainer clip

Figure 2. Rear Caliper Retainer Clip

BRAKE DISC THICKNESS, LATERAL RUNOUT AND WARPAGE

NOTES

The minimum brake disc thickness is stamped on the side of the disc. Replace disc if worn past minimum thickness or badly scored.

Maximum brake disc lateral runout and warpage is 0.008 in (0.2 mm) when measured near the outside diameter.

To replace rear brake disc(s), see the service manual.

REAR BRAKE PAD REPLACEMENT

NOTE

Do not remove rear caliper from mounting bracket unless caliper mounting pins require service. Removing caliper from mounting bracket unnecessarily increases the risk of contaminants falling into mounting pin holes and damaging caliper during vehicle operation.

1. See Figure 3. Remove rear master cylinder reservoir cap (5).

CAUTION

Direct contact of D.O.T. 5 brake fluid with eyes can cause eye irritation, swelling, and redness. Avoid eye contact. In case of eye contact flush with large amounts of water and get medical attention. Swallowing large amounts of D.O.T. 5 brake fluid can cause digestive discomfort. If swallowed, obtain medical attention. Use in well ventilated area. KEEP OUT OF REACH OF CHILDREN. (00144a)

CAUTION

D.O.T. 4 brake fluid will damage painted and body panel surfaces it comes in contact with. Always use caution and protect surfaces from spills whenever brake work is performed. Failure to comply can result in cosmetic damage. (00239b)

CAUTION

Direct contact of D.O.T. 4 brake fluid with eyes can cause irritation. Avoid eye contact. In case of eye contact flush with large amounts of water and get medical attention. Swallowing large amounts of D.O.T. 4 brake fluid can cause digestive discomfort. If swallowed, obtain medical attention. Use in well ventilated area. KEEP OUT OF REACH OF CHILDREN. (00240a)

NOTE

As the piston is pushed back into the caliper, fluid level may rise higher than fluid level mark at about 1/4 in (6.4 mm) below top of reservoir. Fluid may have to be removed to allow for this. See the service manual.

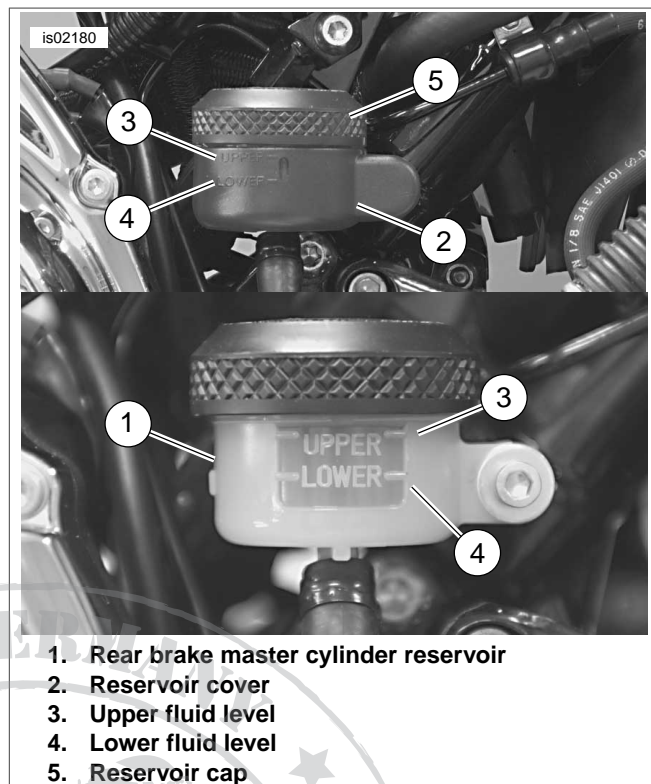

Figure 3. Rear Brake Master Cylinder Reservoir

2. Press the side of the brake caliper body to move the outside brake pad back to push the caliper piston back into its bore.

NOTES

See Figure 4. When replacing rear brake pads, make sure caliper pad spring does not become dislodged and fall out. If it does, install it before installing new pads.

The rear brake caliper does not use the same brake pad set as the front left and front right (not present on all vehicles) calipers.

3. See Figure 5. Remove pad pin plug (3).
4. See Figure 6. Loosen, but do not remove, brake pad pin.

NOTE

Do not completely remove brake pad pin from caliper during the next step. Completely removing pad pin at this time may cause difficulty during assembly.

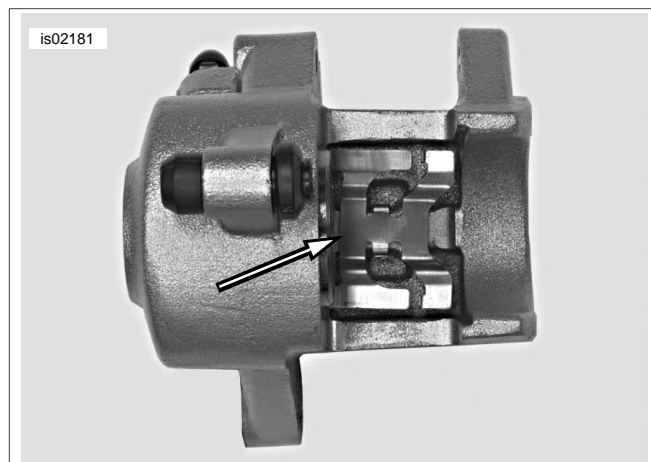

Figure 4. Rear Caliper Pad Spring

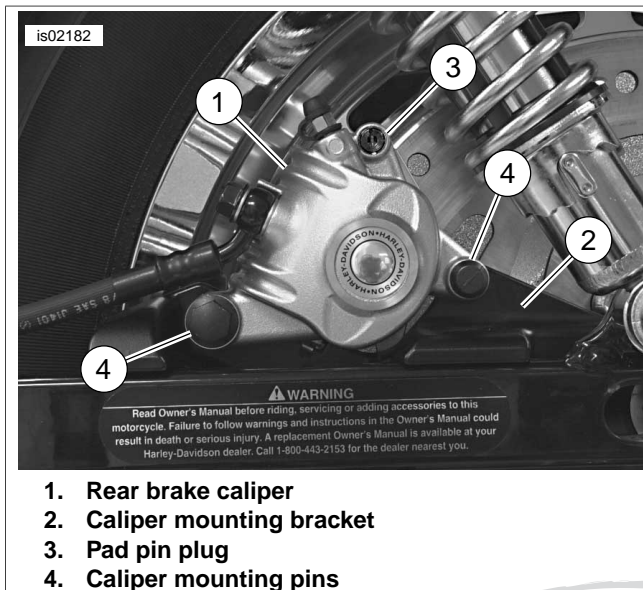

Figure 5. Rear Caliper Assembly

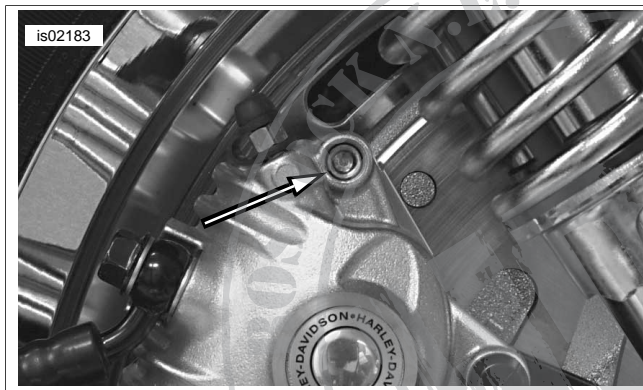

Figure 6. Brake Pad Pin (Plug Removed)

5. Once the piston has been fully retracted into its bore, pull pad pin part way until outside pad drops free. Note the pad's original orientation for installation.
6. See Figure 7. Install new inside brake pad (1) using same orientation as pad previously removed. Make sure front mounting tab (3) is seated in retainer clip (5), which is seated in slot (6) in caliper mounting bracket (7), and pad friction material faces brake disc.
7. While holding new inside pad (1) in place, pull pad pin out, and remove outside brake pad (2). Note the pad's original orientation for installation.
8. Install new outside brake pad (2) using same orientation as the previously removed pad. Make sure front mounting tab (3) is seated in retainer clip (5), which is seated in slot (6) in caliper mounting bracket (7), and pad friction material faces brake disc.
9. Temporarily insert a 1/8 in (3.175 mm) drill bit in caliper pad pin hole to hold both pads in place.
10. Inspect pad pin for grooving and wear. Measure pad pin diameter in an unworn area, and then in the area of any grooving or wear. If wear is more than 0.011 in (0.28 mm), replace pin.

11. Press brake pads firmly against caliper pad spring, remove drill bit and install pad pin. Tighten to 131-173 **in-lbs** (14.7-19.6 Nm).

NOTES

If pad pin does not fit, check the following:

- You are using a set of pads, not two identical pads.
- Caliper pad spring orientation must match Figure 4.
- See Figure 7. Pad front mounting tabs (3) must be fully seated in retaining clip (5), which is seated in mounting bracket slot (6).
- Pads must be pushed tight against caliper pad spring before pad pin is installed.

12. See Figure 5. Install pad pin plug (3). Tighten to 18-25 **in-lbs** (2.0-2.9 Nm).

WARNING

After servicing brakes and before moving motorcycle, pump brakes to build brake system pressure. Insufficient pressure can adversely affect brake performance, which could result in death or serious injury. (00279a)

13. Pump brake pedal to move piston out until it contacts outside brake pad. Verify piston location against pad.

NOTES

Rear brake master cylinder must be in a level position when filling and checking fluid level.

See Figure 3. Reservoir cover (2) may be removed from rear brake cylinder reservoir (1) to more easily verify fluid level in reservoir.

14. Position motorcycle upright (not resting on jiffy stand). See Figure 3. Check brake fluid level in master cylinder. Add enough brake fluid to reservoir until fluid reaches upper fluid level (3). Install master cylinder reservoir cap (5). Replace reservoir cover (2), if removed.

WARNING

After repairing the brake system, test brakes at low speed. If brakes are not operating properly, testing at high speeds can cause loss of control, which could result in death or serious injury. (00289a)

15. Test brake system.
 - a. Turn ignition switch ON. Pump brake lever to verify operation of the brake lamp.
 - b. Test ride the motorcycle. If the brakes feel spongy, bleed the system. See the service manual.

NOTE

Avoid making hard stops for the first 100 miles (160 km). This allows the new pads to become conditioned to the brake discs.

is02184

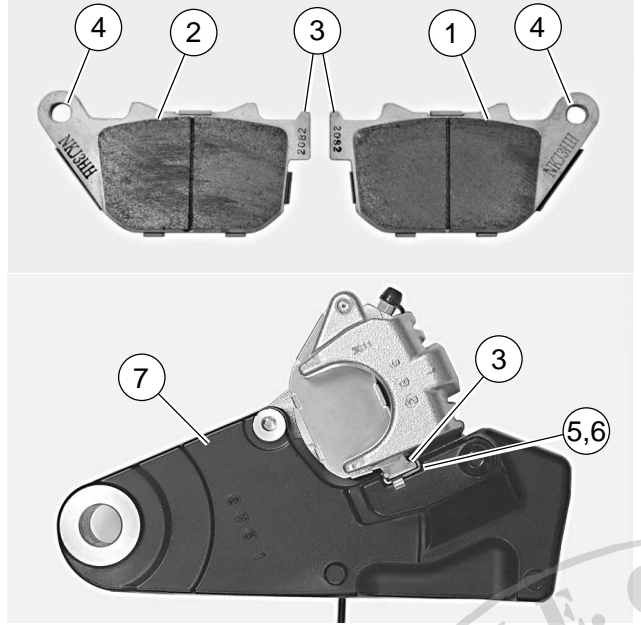

- 1. Inside brake pad
- 2. Outside brake pad
- 3. Front mounting tab
- 4. Pad pin hole
- 5. Retainer clip
- 6. Slot
- 7. Rear caliper mounting bracket

Figure 7. Rear Brake Pads

