



INSTRUCTIONS

-J02936

REV. 03-31-03

Kit Number 42712-04

CHROME BRAKE PEDAL PAD KIT - LARGE

General

This kit is designed for installation on 1986 and later FLHT/C/CI/CUI, FLTR/I, FLHR/I/CI model motorcycles.

This kit can be used with Rider Footboard Kit 50631-04.

See the Service Parts illustration of these instructions for kit contents.

NOTE

A Service Manual for your motorcycle is available from any Harley-Davidson Dealer.

Installation

1. Remove previously installed brake pedal cover from motorcycle.

2. Position and slide new brake pedal cover over brake pedal.
3. Align and install new brake pedal pad with 5/16-18 stud and insert it through the brake pedal cover and brake pedal.
4. Thread the 5/16-18 acorn locknut and washer to the 5/16-18 stud.
5. Tighten locknut to 19 ft-lbs (26 Nm).

WARNING

Brakes are a critical safety component. Contact a Harley-Davidson dealer for brake repair or replacement. Improperly serviced brakes can adversely affect brake performance, which could result in death or serious injury.



Service Parts

Part Number 42712-04

Date 4/03

Chrome Brake Pedal Pad Kit - Large

105524

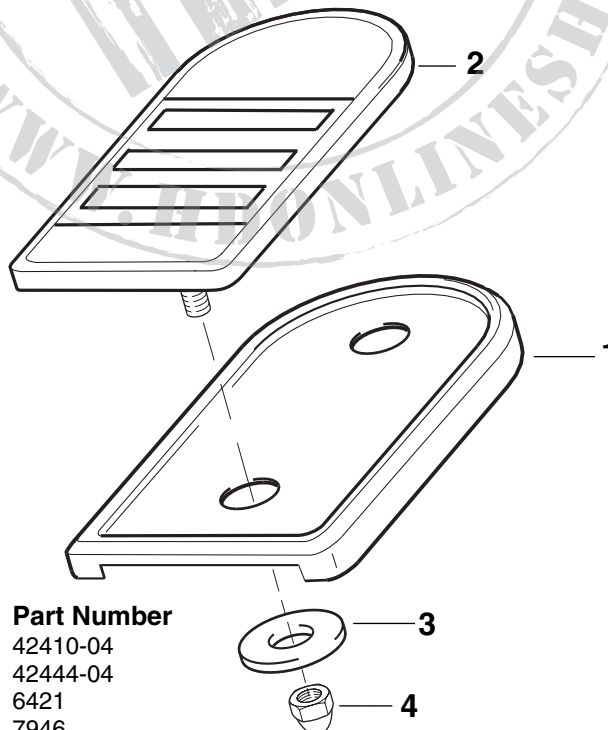

Item	Description/Qty	Part Number
1	Cover, brake pedal	42410-04
2	Pad, brake pedal	42444-04
3	Washer, flat, offset	6421
4	Lochnut, acorn, high crown	7946