



INSTRUCTIONS

-J03168

REV. 06-10-04

Kit Number 42701-05

CUSTOM BRAKE PEDAL PAD

General

This kit is designed for installation on 1984 and later FX Softails and 1993 and later FXDWG model motorcycles.

See Service Parts Illustration for kit contents.

Installation

NOTE

A Service Manual for your motorcycle is available at your Harley-Davidson dealer.

1. See Service Parts Illustration. Remove the previously installed brake pedal cover from the foot brake lever.
2. See Service Parts illustration. Position the pad housing over the brake pedal aligning raised area under plate with oval hole in brake pedal.
3. Position washer (3) under hole of the brake pedal.
4. From top of mounting plate, install tread through pad housing, brake pedal, and washer.
5. From under brake pedal, install locknut (4) to secure pad housing and washer to brake pedal. Tighten locknut to 60-90 **in-lbs** (6.78-10.16 Nm).

WARNING

Whenever the motorcycle brake components are serviced, always test it on dry, clean pavement at slow speeds before putting the vehicle into regular service. Failure to test brakes may lead to an accident which could result in death or serious injury.



Service Parts

Part Number 42701-05

Date 6/04

Custom Brake Pedal Pad

106476

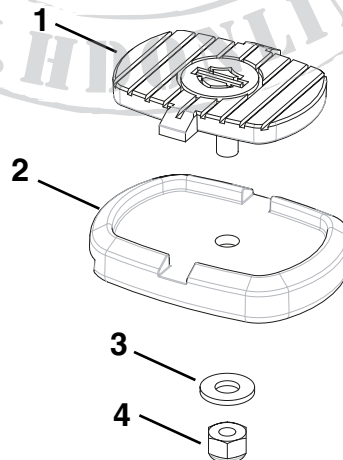

Qty	Description/Qty	Part Number
1	Tread	42718-05
2	Pad housing	42717-05
3	Washer	6703
4	Locknut	7686