



INSTRUCTIONS

-J01461

REV. 1-31-99

Kit Number 42617-99

CHROME REAR BRAKE LEVER KIT

General

This chrome brake pedal is designed for installation on all 1990 and later FXD, FXDL, FXDS-CONV, FXDX and FXDB model motorcycles.

See Service Parts Illustration for kit contents.

NOTE

A Service Manual for your vehicle is available from your Harley-Davidson Dealer.

NOTE

It will be necessary to purchase a replacement snap ring, part number 11005 before installing this kit.

Removal

1. Remove original rear brake lever as follows. Be sure to note all removal processes for installation of new chrome brake lever.
 - a. Remove the exhaust system and heat shield according to the instructions in the Fuel System section of the appropriate Service Manual.
 - b. See Figure 2. Remove the footpeg by removing the two capscrews and all related hardware. Pull the footpeg off. Save the capscrews and hardware for reinstallation.
 - c. Remove snap ring from behind the brake lever and remove brake pedal assembly from foot peg mount.
 - d. See Figure 3. Loosen the entire brake pedal assembly. Back off the jam nut and hold on the flats of the pushrod at the reservoir assembly. Rotate the entire assembly until it is removable. Remove the jam nut from the assembly and save for reinstallation.

Installation

1. See Service Parts Illustration. Install new chrome brake lever assembly, by reversing removal step 1d from above.
2. Reassemble footpeg to new chrome brake lever using the saved spring washer.
3. Replace the snap ring part number 11005 removed in 1c under Removal.
4. Reinstall foot peg by reversing step 1b from above. Tighten the capscrews to 47 **in-lbs** (5.3 N-m).
5. Adjust rear brake free play and brake pedal height according to instructions in the Product section of the applicable Service Manual.
6. Check brake for proper operation following all appropriate warnings and cautions in the Product and Chassis sections of the appropriate Service Manual.



Figure 1. Typical installed rear brake pedal

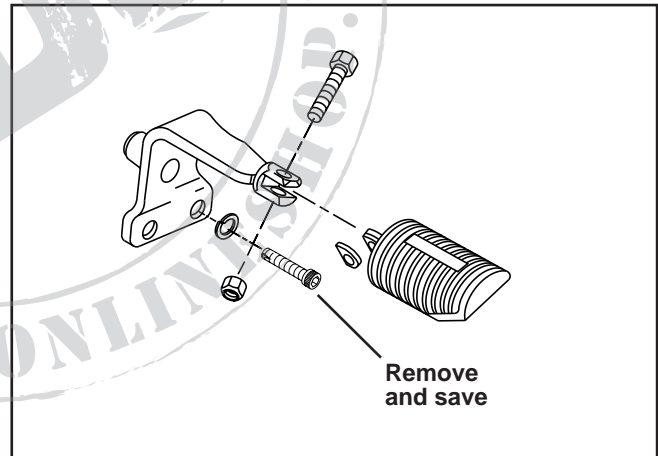

Figure 2. Footpeg removal

7. Reinstall exhaust system and heat shield according to the instructions in the Fuel System section of the appropriate Service Manual.

WARNING

Whenever the brake system is serviced, always test the brakes on dry, clean pavement at slow speeds before putting the motorcycle in regular use. Failure to properly test the brakes may result in brake failure which may result in death or serious injury.

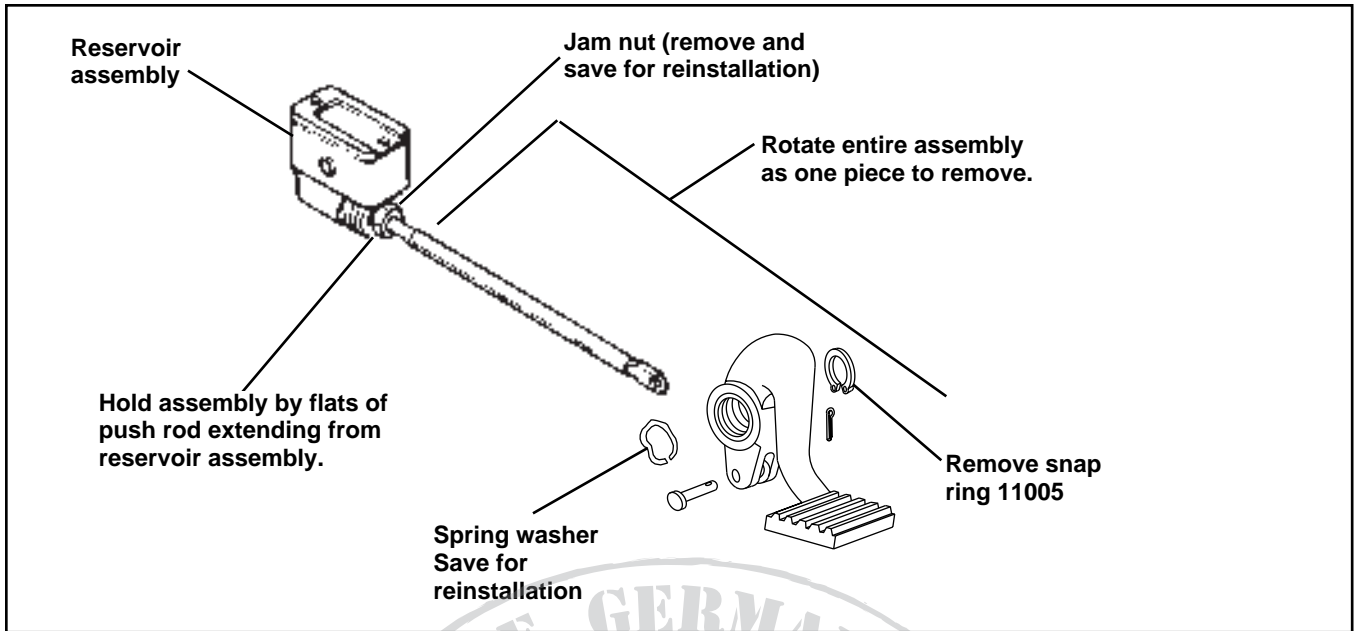

Figure 3. Existing brake assembly removal



Service Parts

Part No. 42617-99

Date 1-99

Chrome Brake Lever Kit

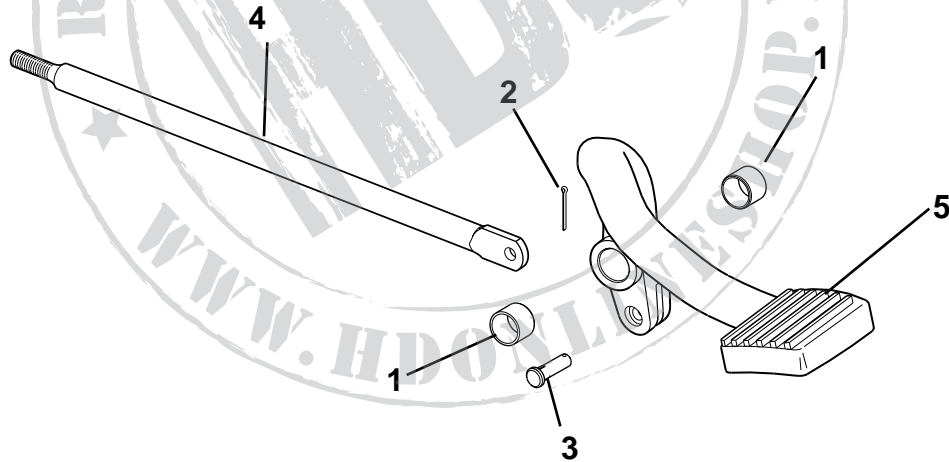

Item	Description	Part Number
1	Bearing sleeves (2)	Not sold separately
2	Cotter pin	Not sold separately
3	Clevis pin	Not sold separately
4	Brake rod	Not sold separately
5	Brake pedal, chrome	Not sold separately