



# INSTRUCTIONS

-J04188

REV. 2006-05-02

## XL CHROME MASTER CYLINDER COVER

### GENERAL

#### Kit Number

42313-07

#### Models

This kit fits 2007 and later XL (Sportster®) model motorcycles.

#### Kit Contents

See Figure 1 and Table 1.

There are no Service Parts available with this kit.

### INSTALLATION

#### NOTE

*To prevent dirt and other contaminants from entering the master-cylinder reservoir, thoroughly clean the cover before removal.*

1. Clean the front master cylinder cover, then remove and discard the two screws that hold the cover in place.

#### NOTE

*If required, follow the instructions in your Owners Manual for filling the master cylinder reservoir with D.O.T. 4 hydraulic brake fluid.*

#### CAUTION

**Direct contact of D.O.T. 4 brake fluid with eyes can cause irritation. Avoid eye contact. In case of eye contact flush with large amounts of water and get medical attention. Swallowing large amounts of D.O.T. 4 brake fluid can cause digestive discomfort. If swallowed, obtain medical attention. Use in well ventilated area. KEEP OUT OF REACH OF CHILDREN. (00240a)**

2. Remove and discard the original cover and gasket, and place the new diaphragm and plate onto the master cylinder reservoir. Position the new chrome cover onto the reservoir over the diaphragm.
3. Install the new polished stainless steel cover screws and tighten to 9-17 **in-lbs** (1.0-2.0 Nm).

# SERVICE PARTS

is02718

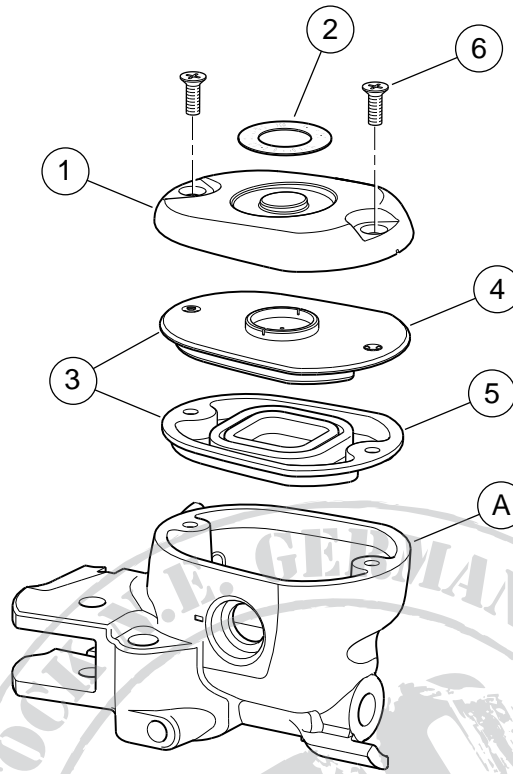

**Figure 1. Service Parts: XL Chrome Master Cylinder Cover**

**Table 1. Service Parts Table**

Item	Description (Quantity)	Part Number
1	Cover, master cylinder reservoir	Not Sold Separately
2	Decal, warning	44791-07
3	Gasket kit (includes items 4 and 5)	42805-04
4	Plate, diaphragm	Not Sold Separately
5	Diaphragm	Not Sold Separately
6	Screw kit (includes 2 screws)	42329-04
<b>Items mentioned in text, but not included in kit:</b>		
A	Front master cylinder	