



# INSTRUCTIONS

-J01374

2014-03-06

## SOFTAIL SPROCKET KIT

### GENERAL

#### Kit Numbers

37785-07, 37793-07, 37800-08, 40126-00, 40126-07, 40134-05, 40134-07, 40264-06, 40264-07, 40445-08, 40447-01, 40447-07, 40455-02, 40474-03, 40474-07, 40508-00, 40530-00, 40530-07, 40698-06, 46624-03, 46628-05, 40228-07, 37834-10, 42200004, 42200029, 42200030, 42200031, 42200007, 42200066, 42200067

#### Models

For model fitment information, see the P&A Retail Catalog or the Parts and Accessories section of [www.harley-davidson.com](http://www.harley-davidson.com) (English only).

#### Additional Parts Required

Proper installation of this kit requires the separate purchase and installation of sprocket mounting hardware. See parts manual for your model and year motorcycle for the correct part numbers.

#### NOTE

A *Spacer Service Kit (29786-01)* is required for the installation of any of the above sprockets on 2000 to 2006 FXSTD models equipped with original equipment (OE) wheels. This spacer must be used in addition to the current OE rubber gasket. The *Spacer Service Kit* is available separately from your Harley-Davidson dealer. For 2007 FXSTD models, the original equipment rubber gasket must be used again.

#### ▲ WARNING

The rider's safety depends upon the correct installation of this kit. Use the appropriate service manual procedures. If the procedure is not within your capabilities or you do not have the correct tools, have a Harley-Davidson dealer perform the installation. Improper installation of this kit could result in death or serious injury. (00333a)

#### NOTICE

Do not re-use sprocket mounting screws. Re-using sprocket mounting screws can result in torque loss and damage to the sprocket and/or belt assembly. (00480b)

#### NOTE

This instruction sheet references service manual information. A service manual for your model motorcycle is required for this installation and is available from a Harley-Davidson dealer.

There are no Service Parts available with this kit.

### INSTALLATION NOTES

#### NOTE

All sprockets listed install in the same manner as the original equipment sprocket. Refer to the *Laced or Cast Rear Wheel*

section in your service manual. Remove existing sprocket according to service manual instructions.

New sprocket mounting screws must be purchased to install this sprocket. Follow the bolt torque procedure in your service manual or, if installing an accessory kit, in the instruction-sheet included with the hardware kit.

If you will be installing this sprocket using newly purchased original equipment bolts, follow the bolt torque procedure in your service manual when tightening the bolts.

If you will be installing this sprocket using a Harley-Davidson Sprocket Hardware Kit accessory follow the bolt torque procedure in the instruction sheet included with that kit.

See Figure 1. If desired, when installing a 7-spoke sprocket onto a 7-spoke wheel, the spokes can be aligned by rotating the sprocket to align the spokes with the wheel spokes.

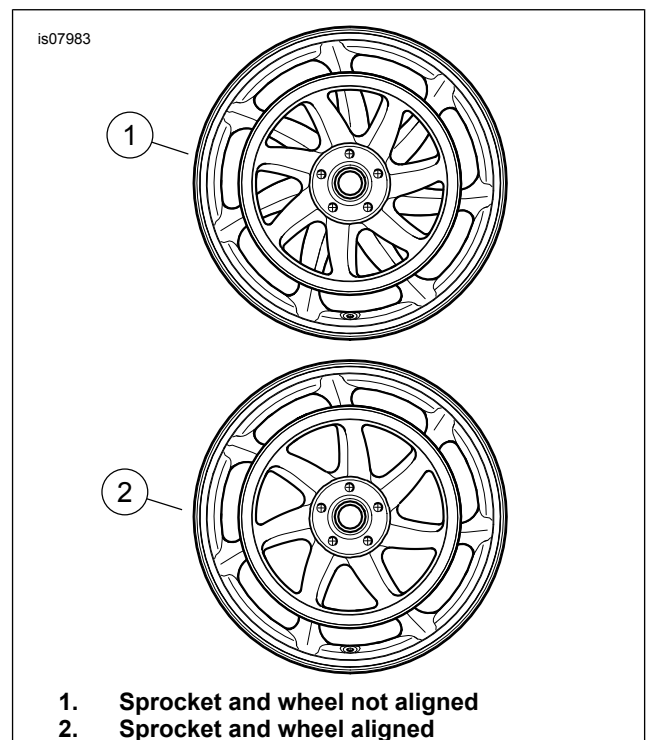

Figure 1. 7-Spoke Sprocket with 7-Spoke Wheel

### Normal Tooth Warranty

This extended warranty applies only to the normal wear that will occur to the tooth profile geometry on the rear belt sprocket. Normal wear is considered wear that occurs when the protective hard coating has worn away exposing the underlying aluminum, changing the profile of the sprocket tooth significantly. Warranty is for five years from date of purchase with unlimited mileage. Warranty claims will require a dated receipt showing proof of purchase from an authorized Harley-Davidson dealer. Warranty only applies to original purchaser of the sprocket. Original owners name must appear on the receipt.

-J01374



Many Harley-Davidson® Parts & Accessories are made of plastics and metals which can be recycled. Please dispose of materials responsibly.

1 / 2

All applications of the sprocket require installation of upper and lower original equipment belt guard, or Harley-Davidson accessory belt guards where applicable. Warranty is voided if these items are not installed.

Excessive chips found in the tooth profile due to abnormal riding conditions will void warranty. Occasional chips in the tooth are to be considered normal and should not be considered a warranty issue.

Decorative external chrome carries the standard parts and accessories warranty. Staking the flange on the backside of the sprocket will pierce through the chrome, this is to be considered a normal process and should not be considered an issue.

All warranty claims must be pursued through your authorized Harley-Davidson dealer.

*NOTE*

*Retain this page for your records and staple Sales Receipt here.*