



INSTRUCTIONS

-J04946

REV. 2009-05-01

REAR 28-SPOKE WHEELS

GENERAL

Kit Number

42196-10

Models

For model fitment information, see the P&A Retail Catalog or the Parts and Accessories section of www.harley-davidson.com (English only).

Additional Parts Required

This kit includes the custom wheel only.

Proper installation of this kit requires the separate purchase of the following parts which are available at a Harley-Davidson dealer:

- Wheel Bearing Remover and Installer (HD-44060-A)
- A Wheel Installation Kit (see Service Parts Tables for part number)

WARNING

The rider's safety depends upon the correct installation of this kit. Use the appropriate service manual procedures. If the procedure is not within your capabilities or you do not have the correct tools, have a Harley-Davidson dealer perform the installation. Improper installation of this kit could result in death or serious injury. (00333a)

NOTE

This instruction sheet references service manual information. A service manual for your model motorcycle is required for this installation and is available from a Harley-Davidson Dealer.

Recommended Additional Parts

The following Harley-Davidson Genuine Motor Accessories are recommended for proper maintenance and cleaning:

- Harley® Bright™ Chrome Cleaner (94683-99)
- Harley® Glaze™ Polish and Sealant (99701-84)
- Harley® Wheel and Spoke Brush (43078-99)
- Harley-Davidson® Wheel and Tire Cleaner (94658-98)

Kit Contents

See Figure 1 and the Service Parts Tables.

INSTALLATION

NOTE

Before removing or installing the wheel, the rear brake caliper must be removed. The cotter pin or spring clip for the axle nut must be replaced. They are available for separate purchase from a Harley-Davidson dealer. See dealer for the correct part number.

1. Remove existing rear wheel assembly. Save axle, axle nut, brake disc and wheel spacers for kit installation. Refer to the service manual.

CAUTION

Do not re-use brake disc/rotor screws. Re-using these screws can result in torque loss and damage to brake components. (00319c)

CAUTION

Do not re-use sprocket mounting screws. Re-using sprocket mounting screws can result in torque loss and damage to the sprocket and/or belt assembly. (00480b)

2. See Figure 1. Install valve stem assembly (E) on wheel. Refer to the service manual.
3. Assemble wheel installation kit components, stock brake disc and sprocket to wheel, using the appropriate service parts table. Refer to the service manual.
4. Install primary bearing with a Wheel Bearing Remover and Installer. Refer to the service manual. The machined groove in the hub face indicates the primary bearing side.
5. Install rear wheel (1), stock axle, sprocket and stock spacers to motorcycle. See the service manual.

MAINTENANCE AND CLEANING

Chrome parts must be maintained regularly so they keep their original shine and luster.

1. Clean heavily-soiled wheel surfaces using Harley-Davidson Wheel and Tire Cleaner, applied with Harley Wheel and Spoke Brush.
2. Thoroughly clean chrome with a good quality chrome cleaner, such as Harley Bright Chrome Cleaner.
3. After cleaning and polishing, seal the finish with a good quality sealer, such as Harley Glaze Polish and Sealant.

SERVICE PARTS

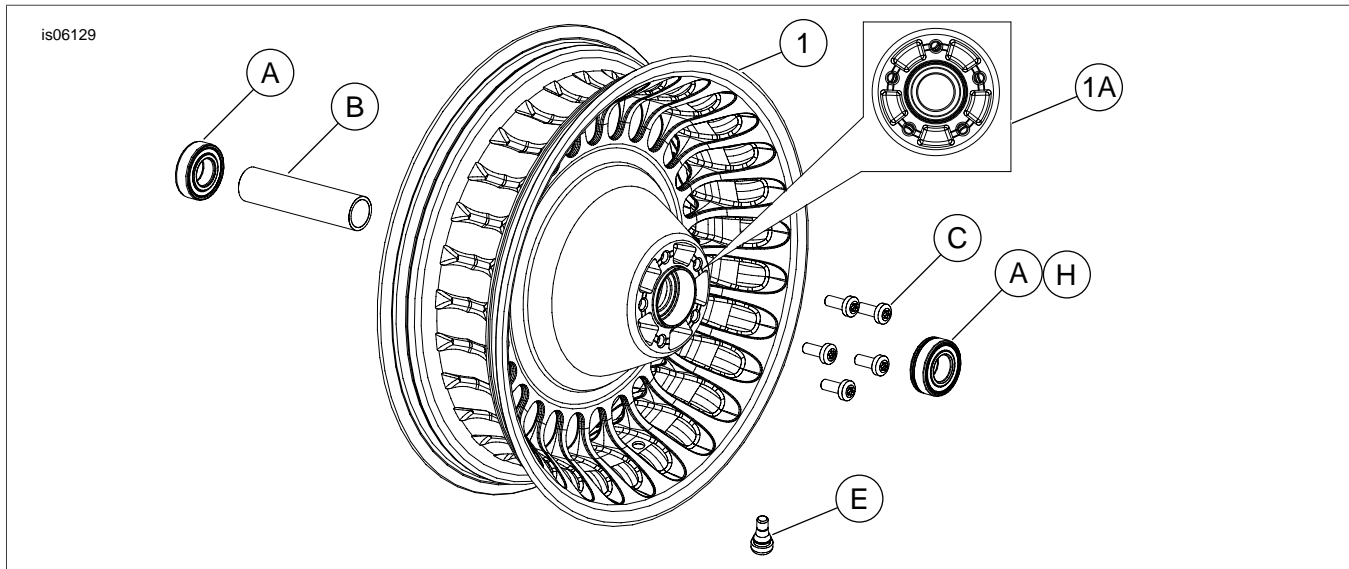

Figure 1. Service Parts: Rear 28-Spoke Wheel (16 inch shown)

Table 1. Service Parts Table

Kit	Installation Kit	Item	Description (Quantity)	Part Number	
42196-10		1	Wheel	Not Sold Separately	
		1A	Machined groove	Not Sold Separately	
		Items requiring separate purchase:			
2009 and later Touring (non-ABS models except FLHTCUTG and FLHXXX)	41456-08B Rear 16x5 inch Fitment	A	Bearing (2)	9276	
		B	Sleeve, bearing spacer	41349-07	
		C	Disc screw (5)	43567-92	
		E	Valve stem assembly	40999-87	
		NOTE: Discard the following components which are provided with this installation kit, but are not required for this fitment.			
			Sleeve, bearing spacer	41358-08	
			Sleeve, bearing spacer	43704-08	
			Shim, bearing	41447-08	
			Valve stem assembly (short)	43157-83A	
			Valve stem assembly (long)	43206-01	
			Screw, sprocket (5)	3109	
			Screw, sprocket (5)	4552	
			Washer (5)	7039	



Table 1. Service Parts Table

Kit	Installation Kit	Item	Description (Quantity)	Part Number	
2009 and later Touring (ABS models except FLHTCUTG and FLHXXX)	41453-08B Rear 16x5 inch Fitment	A	Bearing	9276	
		B	Sleeve, bearing spacer	41349-07	
		C	Disc screw (5)	43567-92	
		E	Valve stem assembly	40999-87	
		H	Bearing, ABS (red side must face inward)	9252	
	NOTE: Discard the following components which are provided with this installation kit, but are not required for this fitment.				
	Sleeve, bearing spacer				41900-08
	Sleeve, bearing spacer				43704-08
	Shim, bearing				41447-08
	Shim, bearing				43904-08
	Valve stem assembly (short)				43157-83A
	Valve stem assembly (long)				43206-01
	Screw, sprocket (5)				3814
	Screw, TORX® (5)				4552
	Washer (5)				7039

