



INSTRUCTIONS

-J04540

REV. 2008-01-07

SWINGARM AXLE COVER KITS

GENERAL

Kit Number

42069-08

Models

For model fitment information, please see the P&A Retail Catalog or the Parts and Accessories section of www.harley-davidson.com (English only).

Additional Parts Required

This instruction sheet references Service Manual information. A Service Manual for your model motorcycle is required for this installation and is available from a Harley-Davidson Dealer.

WARNING

The rider's safety depends upon the correct installation of this kit. Use the appropriate service manual procedures. If the procedure is not within your capabilities or you do not have the correct tools, have a Harley-Davidson dealer perform the installation. Improper installation of this kit could result in death or serious injury. (00333a)

Kit Contents

See Figure 3 and Table 1.

INSTALLATION

Install Extra Spacers for Shotgun Exhaust (If Equipped)

NOTE

The rear muffler on FLSTF and FLSTN models or any Softail model equipped with a shotgun exhaust system does not need to be removed for this installation. However, additional washers may need to be added between muffler support and rear muffler bracket to give proper clearance between muffler and cover.

If space is needed:

1. Loosen rear exhaust pipe at port. Remove bolt that attaches rear muffler bracket to rear muffler support.
2. Locate 5/16 in. washers included with kit and install washers as needed between muffler support and rear muffler bracket. Reinstall muffler support bolt. Re-tighten bolts loosened at port in Step 1.

Install Mounting Brackets - All Models

NOTE

It is not necessary to remove rear wheel for this installation.

1. Block vehicle under frame so all weight is off rear wheel, and so tire is slightly raised off the floor following instructions in the appropriate Service Manual.

2. Disassemble axle assembly by removing rear axle nut cover (if present), C-clip, axle nut and washer. Discard washer. Set everything else aside for later use.
3. Slide rear axle from hub to provide sufficient clearance for mounting bracket, but do not remove rear axle or rear wheel.

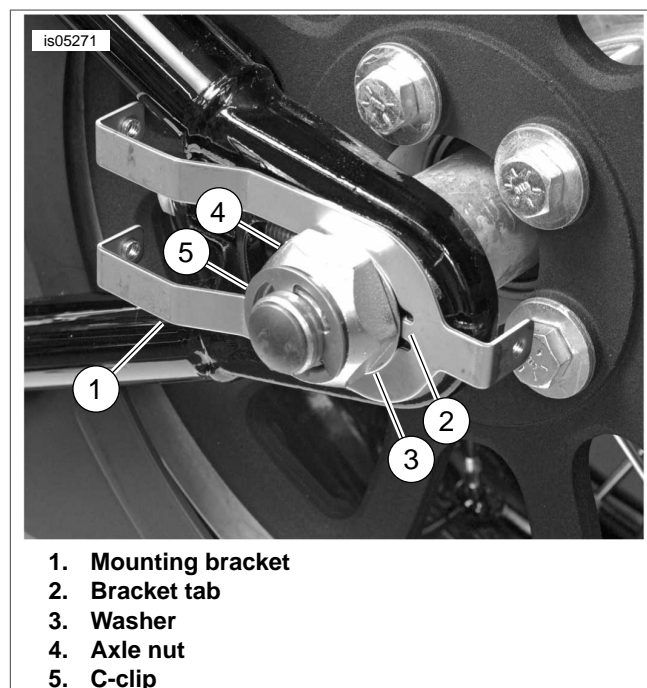

Figure 1. Install Mounting Brackets

4. See Figure 1. Position one mounting bracket (1) on left swingarm, as shown. Move bracket toward rear of swingarm so tab (2) is touching the inside edge of axle slot in swingarm.
5. Position second mounting bracket on right side of vehicle. While holding bracket in place, slide axle back into position.
6. Complete axle bracket installation by reinstalling thrust washer (3) (from kit) and nut (4) removed in Step 2. Tighten axle nut to 60-65 ft-lbs (81-88 Nm).
7. Install C-clip (5) to left side axle slot.

WARNING

Check wheel bearing end play after tightening axle nut to specified torque. Excessive end play can adversely affect stability and handling. Insufficient end play can cause bearing seizure. Either condition can cause loss of control, which could result in death or serious injury. (00285a)

8. Check wheel bearing end play following the instructions in the appropriate Service Manual.
9. Verify belt drive tension following the instructions in the appropriate Service Manual.

Install Swingarm Axle Covers

1. See Figure 2. Place left cover (1) over mounting bracket tabs on left side of vehicle. While holding cover in place, insert one screw (2) included with kit into each of three holes in cover and bracket. Tighten securely with a hex wrench.
2. Repeat this procedure for right cover on right side of vehicle.
3. Test ride motorcycle for proper operation.

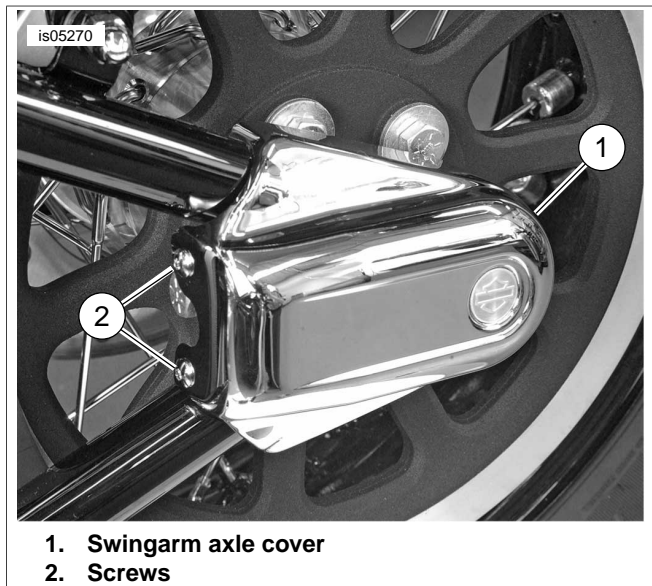

Figure 2. Install Cover

SERVICE PARTS

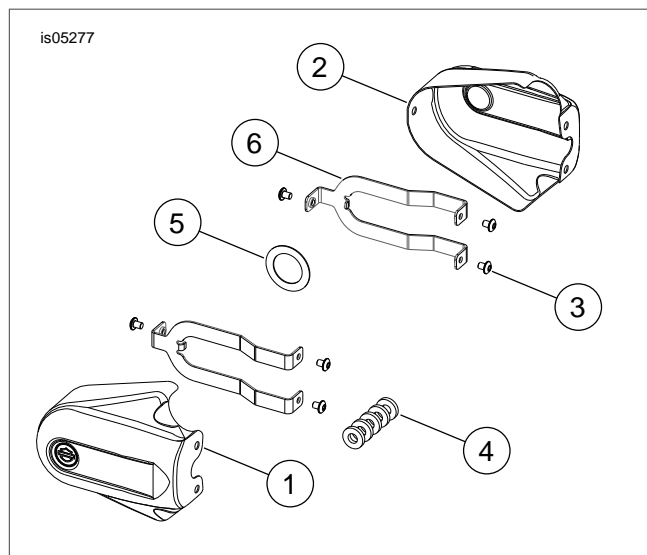

Figure 3. Service Parts: Swingarm Axle Covers

Table 1. Service Parts Table

Item	Description (Quantity)	Part Number
1	Axle cover, right side with Bar & Shield	48128-08
2	Axle cover, left side with Bar & Shield	48129-08
3	Buttonhead screw (6)	3047
4	Washer, heat treated (5)	6109
5	Thrust washer	6553
6	Axle nut cover mounting bracket (2)	48065-08

