



INSTRUCTIONS

-J03529

REV. 2007-04-26

CHROME FRONT BRAKE CALIPER KIT

GENERAL

Kit Number

442012-06A

Models

For model fitment information, please see the P&A Retail Catalog or the Parts and Accessories section of www.harley-davidson.com (English only).

Additional Parts Required

Four **new** brake line gaskets (H-D Part Number 41751-06A) will be required for proper installation of this kit.

Separate purchase of additional parts may be required for proper installation of this Front Brake Caliper Kit on your model motorcycle. Please see the P&A Retail Catalog or the Parts and Accessories section of www.harley-davidson.com (English only) for a list of required parts for your model.

Tools and Supplies Required

Fresh, uncontaminated brake fluid will be needed. Refer to your Owner's Manual or the Service Manual **for this year and model motorcycle** to determine the correct brake fluid for this vehicle.

⚠ WARNING

The rider's safety depends upon the correct installation of this kit. Use the appropriate service manual procedures. If the procedure is not within your capabilities or you do not have the correct tools, have a Harley-Davidson dealer perform the installation. Improper installation of this kit could result in death or serious injury. (00333a)

NOTE

This instruction sheet references Service Manual information. A Service Manual for your model motorcycle is available from a Harley-Davidson Dealer.

⚠ WARNING

Brakes are a critical safety component. Contact a Harley-Davidson dealer for brake repair or replacement. Improperly serviced brakes can adversely affect brake performance, which could result in death or serious injury. (00054a)

Kit Contents

See Figure 3 and Table 1.

INSTALLATION

Preparation for Service

⚠ WARNING

To prevent accidental vehicle start-up, which could cause death or serious injury, remove maxi-fuse before proceeding. (00251a)

1. Refer to the Service Manual and follow the instructions given to remove the maxi-fuse.

Original Front Brake Caliper Removal

★ CAUTION

Remove brake line components carefully. Damage to seating surfaces can cause leakage. (00320a)

NOTE

When performing the following Step, place a container under the caliper to catch brake fluid that may flow from the brake line when removing the banjo bolt.

1. See Figure 1. Refer to FRONT BRAKE CALIPERS: REMOVAL in the Service Manual, and follow the instructions to:
 - a. remove the banjo bolt with bleeder valve (2) and both gaskets (4), and
 - b. detach the front brake line (3) from the caliper.
 - c. Discard the gaskets. **For this installation, the banjo bolt (2) can also be discarded.**
 - d. Remove the caliper mounting bolts (1). Lift the brake caliper assembly upward to remove it from the brake disc.

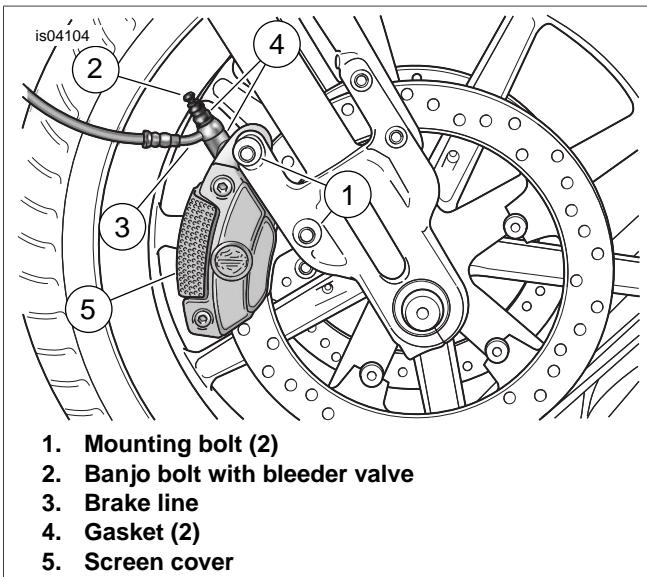

Figure 1. Remove Existing Caliper

2. Remove the brake pads from the caliper. Refer to BRAKE PADS AND DISCS: BRAKE PAD REPLACEMENT, FRONT BRAKE CALIPER in the Service Manual.
 - a. Remove the screen cover (5) from the caliper.
 - b. See Figure 2. Note the orientation of the brake pads, and remove the retaining clip (2), pad pin (1) and brake pads from the caliper.
Also note the position of the brake pads at removal, so they can be installed back in the same location.
3. Repeat the procedure for the opposite-side caliper.

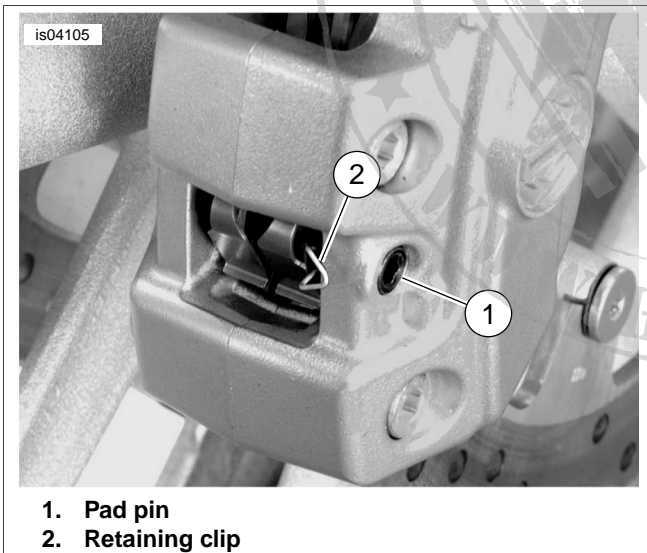

Figure 2. Front Caliper Pad Pin

Pad and Pin Inspection

1. Refer to BRAKE PADS AND DISCS: INSPECTION in the Service Manual, and follow the instructions given to inspect the brake pads. If any front brake pad is worn to 0.5 mm (0.020 inch) or less above the backing plate, replace **all four front pads**.

2. Inspect the brake disc thickness, lateral runout and warpage. If necessary, follow the instructions in the Service Manual under FRONT WHEEL to replace the discs.

Chrome Caliper Installation

1. See Figure 3. Obtain the correct-side **new** chrome caliper assembly from the kit. Remove the screen cover (5), retaining clip and pad pin (4) from the caliper.

NOTE

Do not remove the shipping plug protecting the brake line threaded hole until ready to install the brake line.

2. Place the caliper over the brake disc with the brake line threaded hole (protected by a shipping plug) facing upward.
3. See Figure 1. Obtain two of the brake caliper mounting bolts (1), removed earlier. Loosely install both bolts through the front fork and into the chrome caliper.
Alternately tighten the mounting bolts to 38.0-51.5 Nm (28-38 ft-lbs).

4. Install the brake pads removed earlier or, if necessary, new brake pads into the caliper.
5. See Figure 2. Install the **new** pad pin (1) through the inner and outer brake pads. Tighten to 8.5-11.5 Nm (75-100 in-lbs).
6. Install the **new** retaining clip (2) onto the pad pin.

NOTE

Ensure that the screen cover is oriented with the single tab end up, and the double tab end down.

7. See Figure 1. Install the **new** screen cover (5) onto the caliper.

WARNING

Replace brake line gaskets. Re-using original gaskets can cause brake failure and loss of vehicle control, which could result in death or serious injury. (00318a)

CAUTION

Avoid leakage. Be sure gaskets, banjo bolt(s) and brake line are clean and undamaged before assembly. (00323a)

8. Remove the shipping plug from the brake line threaded hole in the caliper.
9. Obtain two **new** brake line gaskets (Item 4, purchased separately). Connect the brake line (3) to the caliper using new gaskets and the **new** banjo bolt with bleeder valve (2) from the kit. Tighten the banjo bolt to 23.0-26.0 Nm (17-19 ft-lbs).
10. Repeat the installation procedure for the opposite-side caliper.

Final Assembly

1. Refer to BLEEDING BRAKES in the Service Manual, and follow the instructions to bleed the front brakes.
2. Verify that the Ignition/Light Key Switch is turned to the OFF position.
3. Refer to the Service Manual and follow the instructions given to re-install the maxi-fuse.

Test the Brakes

1. Turn the Ignition/Light Key Switch to the ON position.
2. Pump the front brake hand lever to verify operation of the brake lamp.

WARNING

After repairing the brake system, test brakes at low speed. If brakes are not operating properly, testing at high speeds can cause loss of control, which could result in death or serious injury. (00289a)

3. Test ride the motorcycle. If the brakes feel spongy, bleed the brake system again.

NOTE

IF THE BRAKE PADS HAVE BEEN REPLACED, avoid making hard stops for the first 100 miles (160 km). This allows the new pads to become conditioned to the brake discs.



SERVICE PARTS

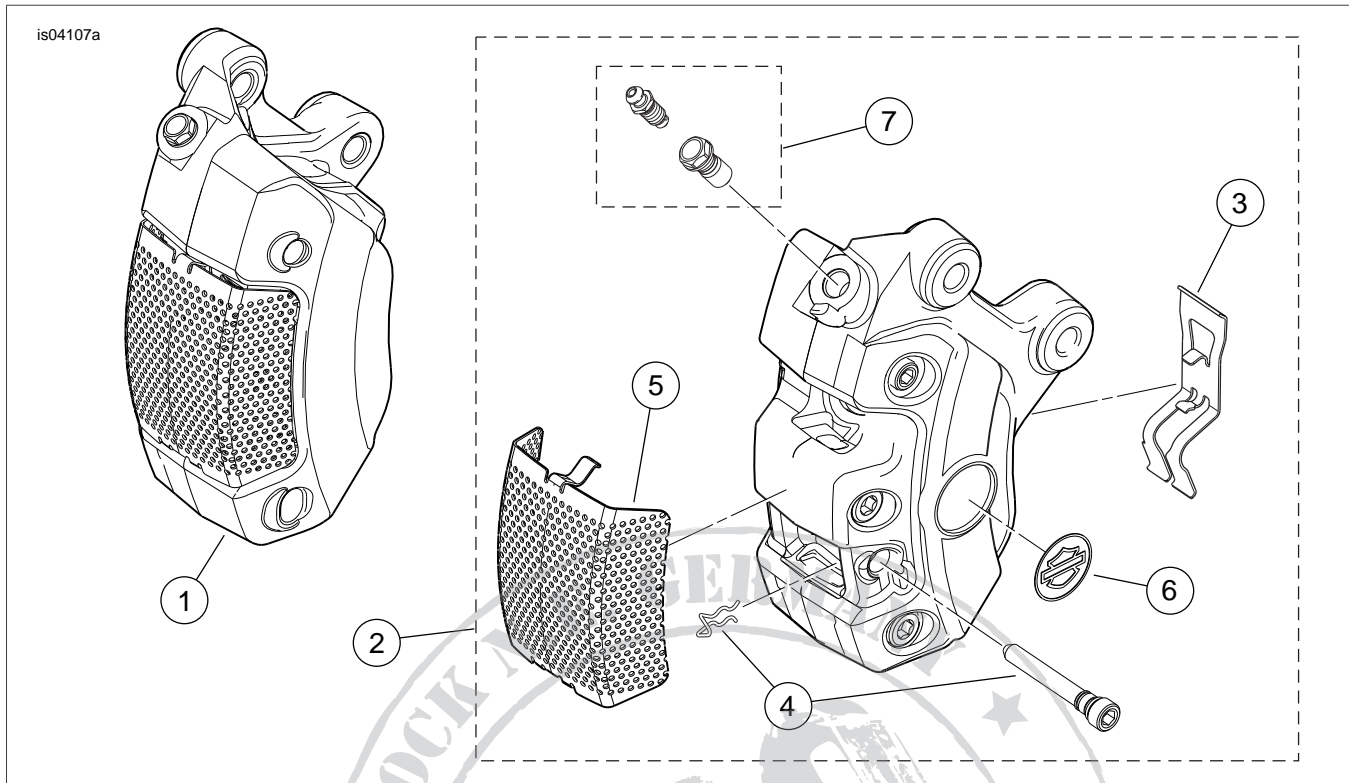

Figure 3. Service Parts: Chrome Front Brake Caliper Kit

Table 1. Service Parts Table

Item	Description (Quantity)	Part Number
1	Chrome caliper assembly (left side) (includes items 3 through 7)	42013-06
2	Chrome caliper assembly (right side) (includes items 3 through 7)	42014-06
3	• Pad spring, front caliper	42852-06
4	• Pad pin kit (includes pin and retaining clip)	42849-06
5	• Caliper cover (screen)	42019-06
6	• Medallion, Bar & Shield logo	14449-06
7	• Banjo bolt and bleeder assembly (bright finish)	5457