



# INSTRUCTIONS

-J04237

REV. 2008-10-17

## FRONT NINE-SPOKE WHEELS

### GENERAL

#### Kit Number

41880-07, 41886-07, 41886-09

#### Models

For model fitment information, see the P&A Catalog or the Parts and Accessories section of [www.harley-davidson.com](http://www.harley-davidson.com).

#### NOTE

*Accessory hub caps are not compatible with this wheel.*

#### Additional Parts Required

This kit includes the custom wheel only. Some kits also include a hub cap.

Proper installation of this kit requires the separate purchase of the following parts which are available at a Harley-Davidson dealer:

- Wheel Bearing Remover and Installer (HD-44060-A)
- Wheel Installation Kit (See tables for part number)
- Hub Cap (43986-00 - if installing kit 41886-09 on a 2009 and Later TLE/U sidecar)

The following Harley-Davidson Genuine Motor Accessories are recommended for proper maintenance and cleaning:

- Harley® Bright™ Chrome Cleaner (94683-99)
- Harley® Glaze™ Polish and Sealant (99701-84)
- Harley® Wheel and Spoke Brush (43078-99)
- Harley-Davidson® Wheel and Tire Cleaner (94658-98)

### WARNING

**The rider's safety depends upon the correct installation of this kit. Use the appropriate service manual procedures. If the procedure is not within your capabilities or you do not have the correct tools, have a Harley-Davidson dealer perform the installation. Improper installation of this kit could result in death or serious injury. (00333a)**

#### NOTE

*This instruction sheet references service manual information. A service manual for your model motorcycle is required for this installation and is available from a Harley-Davidson dealer.*

### Kit Contents

See Figure 1 and Service Parts Tables.

### INSTALLATION

1. Remove existing front wheel assembly. Save axle, axle nut, brake disc, and wheel spacers for kit installation. Refer to FRONT WHEEL in service manual.

**For FLSTC and FLSTN models:** Discard moon-style hub cap.

### CAUTION

**Do not re-use brake disc screws. Re-using disc screws can result in torque loss and damage to rotor and/or brake assembly. (00319b)**

2. See Figure 1. Install valve stem assembly (D) on wheel. Refer to TIRES in service manual.
3. Assemble wheel installation kit components and brake disc(s) to wheel, using the appropriate service parts table. Refer to FRONT WHEEL in service manual.

#### NOTES

*Install the primary bearing first with the WHEEL BEARING REMOVER/INSTALLER, following the service manual instructions.*

*The machined grooves in the hub face indicate the primary bearing side.*

*The front wheel should be installed so that the valve stem is on the right side of the motorcycle.*

4. Install wheel assembly parts from the appropriate service parts table for your fitment and stock brake disc(s). Discard parts from the installation kit that are not required. Refer to FRONT WHEEL in service manual.
5. **For FLSTC and FLSTN Models:** Install wheel kit and right side wheel spacer provided in kit installation.  
**All other models:** Install wheel spacers previously removed.
6. Install front wheel (1), stock axle and stock axle nut. Refer to FRONT WHEEL in service manual.
7. **For 2009-Later TLE/U Sidecars:** Assemble the sidecar brake disc and hub cap (purchased separately) to the wheel. The brake disc is to be installed on the side of the wheel opposite the valve stem. Install wheel according to the sidecar service manual.

## MAINTENANCE AND CLEANING

### NOTE

*This wheel assembly includes plugs that have been installed in the openings between the brake disc mounting holes on one side of the wheel. Missing or damaged plugs can be replaced using the Wheel Plug Kit (41966-07).*

Chrome parts must be maintained regularly so they keep their original shine and luster.

1. Clean heavily-soiled wheel surfaces using Harley-Davidson Wheel and Tire Cleaner, applied with Harley Wheel and Spoke Brush.
2. Thoroughly clean chrome with a good quality chrome cleaner, such as Harley Bright Chrome Cleaner.
3. After cleaning and polishing, seal the finish with a good quality sealer, such as Harley Glaze Polish and Sealant.



## SERVICE PARTS

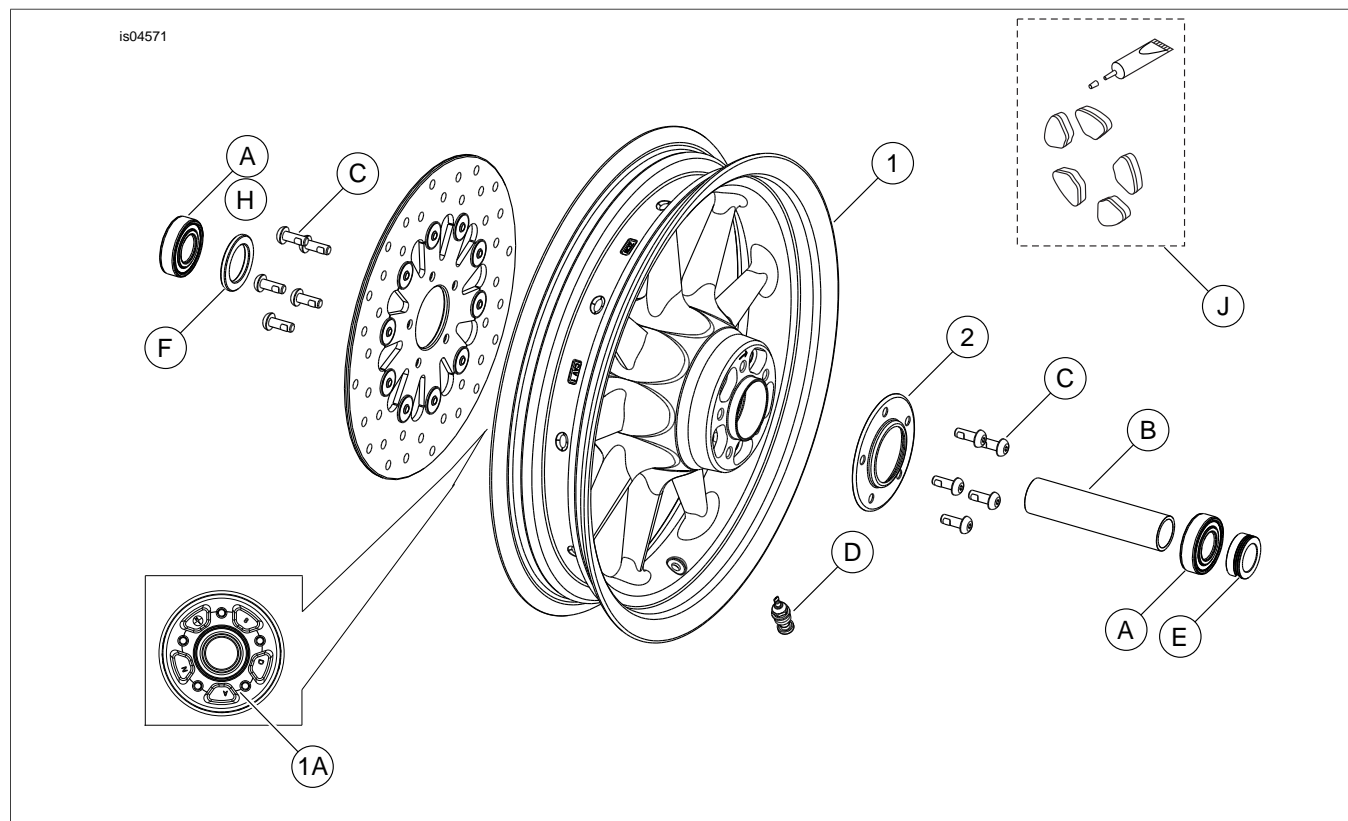

Figure 1. Service Manual: Front Nine-Spoke Wheels

Table 1. Service Parts Table

Kit	Installation Kit	Item	Description (Quantity)	Part Number	
41886-07		1	Wheel	Not Sold Separately	
		1A	Machined groove	Not Sold Separately	
		J	Plug Service Kit	41966-07	
2000-2007 Touring	43848-08 16x3 inch front wheel	A	Bearing (2)	9247	
		B	Sleeve, bearing spacer	43517-00	
		C	Screw (10)	3655A	
		D	Valve stem assembly (long)	43206-01	
		NOTE: Discard the following components which are provided with this installation kit, but are not required for this fitment.			
			Sleeve, bearing spacer	43633-06	
			Sleeve, bearing spacer	43641-01	
			Sleeve, bearing spacer	43755-04	
			TORX® screw (10)	3762M	
			Valve stem assembly (short)	43157-83A	
	Washer (10)	6966M			

**Table 1. Service Parts Table**

Kit	Installation Kit	Item	Description (Quantity)	Part Number	
2008 Touring without ABS	43851-08 16x3 inch front wheel	A	Bearing (2)	9276	
		B	Sleeve, bearing spacer	41900-08	
		C	Screw (10)	3655A	
		D	Valve stem assembly (long)	43206-01	
		F	Shim, bearing (install under primary bearing)	43903-08	
		NOTE: Discard the following components which are provided with this installation kit, but are not required for this fitment.			
			Shim, bearing	43315-07	
			Sleeve, bearing spacer	41349-07	
			Spacer, axle	41504-07	
			Spacer, axle	41695-07	
			Valve stem assembly (short)	43157-83A	
		2008 Touring with ABS	41454-08 16x3 inch front wheel	A	Bearing
B	Sleeve, bearing spacer			41900-08	
C	Screw (10)			3655A	
D	Valve stem assembly (long)			43206-01	
F	Shim, bearing (install under primary bearing)			43903-08	
H	Bearing, ABS (red side must face inward)			9252	
NOTE: Discard the following components which are provided with this installation kit, but are not required for this fitment.					
	Shim, bearing			41450-08	
	Sleeve, bearing spacer			41748-08	
	TORX screw (10)			3762M	
	Valve stem assembly (short)			43157-83A	
	Washer (10)			6966M	

**Table 2. Service Parts Table**

Kit	Installation Kit	Item	Description (Quantity)	Part Number
41880-07		1	Wheel	Not Sold Separately
		1A	Machined groove	Not Sold Separately
		2	Hub cap	43986-00
		J	Plug Service Kit	41966-07



**Table 2. Service Parts Table**

Kit	Installation Kit	Item	Description (Quantity)	Part Number	
2000-2006 FLST, FLSTC, FLSTF and FLSTN (except 2006 FLSTFSE2)	43833-07 16x3 inch front wheel	A	Bearing (2)	9267	
		B	Sleeve, bearing spacer	43608-00	
		C	Screw (10)	3655A	
		D	Valve stem assembly (long)	43206-01	
		E	Spacer, axle (included to replace the moon-style hub cap on FLSTC and FLSTN models)	43617-00A	
		NOTE: Discard the following components which are provided with this installation kit, but are not required for this fitment.			
			Sleeve, bearing spacer	43536-00	
			Sleeve, bearing spacer	43613-00	
			Spacer, axle	40910-00A	
			Spacer, axle	43313-98	
			Valve stem assembly (short)	43157-83A	
2007 and later FLSTC and FLSTN	43851-08 16x3 inch front wheel	A	Bearing (2)	9276	
		B	Sleeve, bearing spacer	41349-07	
		C	Screw (10)	3655A	
		D	Valve stem assembly (long)	43206-01	
		E	Spacer, axle (included to replace the moon-style hub cap on FLSTC and FLSTN models)	41695-07	
		F	Shim, bearing (install under primary (left side) bearing)	43315-07	
		NOTE: Discard the following components which are provided with this installation kit, but are not required for this fitment.			
			Shim, bearing	43903-08	
			Sleeve, bearing spacer	41900-08	
			Spacer, axle	41504-07	
			Valve stem assembly (short)	43157-83A	

**Table 3. Service Parts Table**

Kit	Installation Kit	Item	Description (Quantity)	Part Number	
41886-09		1	Wheel	Not Sold Separately	
		1A	Machined groove	Not Sold Separately	
		J	Plug Service Kit	41966-07	
2009 and later Touring without ABS, 2009 and later TLE/U Sidecars	43851-08 17x3 inch front wheel	A	Bearing (2)	9276	
		B	Sleeve, bearing spacer	41900-08	
		C	Screw (10)	3655A	
		D	Valve stem assembly (long)	43206-01	
		NOTE: Discard the following components which are provided with this installation kit, but are not required for this fitment.			
			Shim, bearing	43315-07	
			Shim, bearing	43903-08	
			Sleeve, bearing spacer	41349-07	
			Spacer, axle	41504-07	
			Spacer, Axle	41695-07	
	Valve stem assembly (short)	43157-83A			

**Table 3. Service Parts Table**

Kit	Installation Kit	Item	Description (Quantity)	Part Number	
2009 and later Touring with ABS	41454-08 17x3 inch front wheel	A	Bearing	9276	
		B	Sleeve, bearing spacer	41900-08	
		C	Screw (10)	3655A	
		D	Valve stem assembly (long)	43206-01	
		H	Bearing, ABS (red side must face inward)	9252	
		NOTE: Discard the following components which are provided with this installation kit, but are not required for this fitment.			
			Shim, bearing	41450-08	
			Shim, bearing	43903-08	
			Sleeve, bearing spacer	41748-08	
			TORX screw (10)	3762M	
			Valve stem assembly (short)	43157-83A	
			Washer (10)	6966M	

