



INSTRUCTIONS

-J05886

2014-04-02

BRAKE CALIPER KIT

GENERAL

Kit Number

41300116

Models

For model fitment information, see the P&A retail catalog or the Parts and Accessories section of www.harley-davidson.com (English only).

This kit is a direct replacement for the original equipment (OE) components, and installs in the same manner.

Installation Requirements

Fresh, uncontaminated hydraulic brake fluid from a sealed container is needed. Refer to the service manual for this year/model motorcycle to determine the correct brake fluid.

⚠ WARNING

The rider's safety depends upon the correct installation of this kit. Use the appropriate service manual procedures. If the procedure is not within your capabilities or you do not have the correct tools, have a Harley-Davidson dealer perform the installation. Improper installation of this kit could result in death or serious injury. (00333a)

NOTE

This instruction sheet refers to service manual information. A service manual for this year/model motorcycle is required for this installation. One is available from a Harley-Davidson dealer.

⚠ WARNING

Brakes are a critical safety component. Contact a Harley-Davidson dealer for brake repair or replacement. Improperly serviced brakes can adversely affect brake performance, which could result in death or serious injury. (00054a)

⚠ WARNING

The rider's safety depends upon the correct installation of this kit. Dealer installation is required for vehicles equipped with ABS brakes. Proper installation of this kit requires the use of special tools available only through a Harley-Davidson Dealer. An improperly serviced brake system can adversely affect brake performance, which could result in death or serious injury. (00578b)

⚠ WARNING

When any hydraulic brake component, line or connection is loosened or replaced on an ABS motorcycle, Digital Technician II must be used during the brake bleeding procedure to verify all air is removed from the system. Failure to properly bleed the brake system could adversely affect braking, which could result in death or serious injury. (00585c)

Kit Contents

See Figure 1 and Table 1.

PREPARATION

⚠ WARNING

To prevent accidental vehicle start-up, which could cause death or serious injury, remove main fuse before proceeding. (00251b)

NOTE

- **2007- later vehicles WITH security siren:** With security fob present, turn ignition switch ON. See the service manual. After system is disarmed, turn ignition switch OFF. **IMMEDIATELY** remove the main fuse.
- **2006 vehicles WITH security siren:** Disarm the siren with the key fob or security code. See the service manual. Remove the main fuse.
- **Vehicles WITHOUT security siren:** See the service manual. Remove the main fuse.

INSTALLATION

⚠ CAUTION

Direct contact of D.O.T. 4 brake fluid with eyes can cause irritation. Avoid eye contact. In case of eye contact flush with large amounts of water and get medical attention. Swallowing large amounts of D.O.T. 4 brake fluid can cause digestive discomfort. If swallowed, obtain medical attention. Use in well ventilated area. **KEEP OUT OF REACH OF CHILDREN.** (00240a)

NOTICE

D.O.T. 4 brake fluid will damage painted and body panel surfaces it comes in contact with. Always use caution and protect surfaces from spills whenever brake work is performed. Failure to comply can result in cosmetic damage. (00239b)

NOTE

If DOT 4 brake fluid contacts painted surfaces, **IMMEDIATELY** flush area with clear water.

Cover nearby motorcycle surfaces to protect against damage to the finish caused by spillage or splash of DOT 4 brake fluid.

⚠ WARNING

Replace brake line gaskets. Re-using original gaskets can cause brake failure and loss of vehicle control, which could result in death or serious injury. (00318a)

NOTICE

Remove brake line components carefully. Damage to seating surfaces can cause leakage. (00320a)

-J05886



Many Harley-Davidson® Parts & Accessories are made of plastics and metals which can be recycled. Please dispose of materials responsibly.

1 / 2

1. See the service manual. Remove both front brake calipers.
2. Install the **new** front brake calipers per service manual instructions.

COMPLETION

NOTE

Verify that the ignition key switch is in the OFF position **before** installing the main fuse.

1. See the service manual. Install the main fuse.

SERVICE PARTS

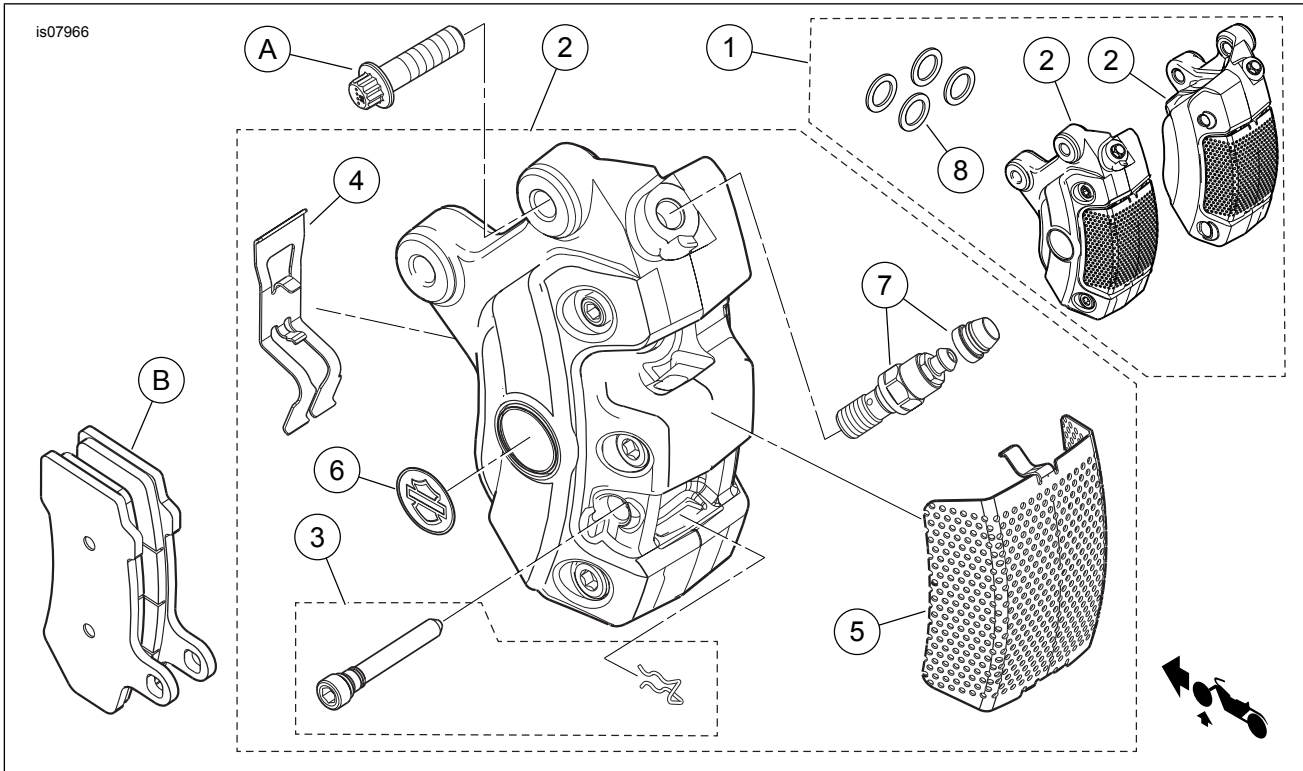

Figure 1. Service Parts, Brake Caliper Kit

Table 1. Service Parts

Item	Description (Quantity)	Part Number
1	Brake caliper kit, front (Red) (includes Items 2-8)	41300116
2	• Caliper assembly, front brake, Red (left, includes Items 3-7)	41300117
	• Caliper assembly, front brake, Red (right, includes Items 3-7)	41300118
3	• ... Pad pin kit (includes retainer clip)	42849-08
4	• ... Spring, front brake pad anti-rattle	42852-06A
5	• ... Caliper cover (screen), Black	41300119
6	• ... Medallion, Bar & Shield logo	44341-08
7	• ... Banjo bolt/bleeder assembly (includes cap, Part No. 42853-06)	5464
8	• Sealing gasket (4)	41751-06A
Items mentioned in text, but not included in kit:		
A	Original equipment (OE) lower caliper mount bolt (4), Part No. 44160-00	
B	Pad kit, front brake, Part No. 41854-08 (includes Item 3)	

⚠ WARNING

After servicing brakes and before moving motorcycle, pump brakes to build brake system pressure. Insufficient pressure can adversely affect brake performance, which could result in death or serious injury. (00279a)

⚠ WARNING

After repairing the brake system, test brakes at low speed. If brakes are not operating properly, testing at high speeds can cause loss of control, which could result in death or serious injury. (00289a)