



INSTRUCTIONS

-J04452

2007-05-29

SOFTAIL CHROME REAR AXLE ADJUSTER HARDWARE KIT

GENERAL

Kit Number

41202-08

Models

For model fitment information, please see the P&A Retail Catalog or the Parts and Accessories section of www.harley-davidson.com (English only).

Additional Parts Required

NOTE

This instruction sheet references Service Manual information. A Service Manual for your model motorcycle is required for this installation and is available from a Harley-Davidson Dealer.

Kit Contents

See Figure 2 and Table 1.

INSTALLATION

⚠ WARNING

The rider's safety depends upon the correct installation of this kit. Use the appropriate service manual procedures. If the procedure is not within your capabilities or you do not have the correct tools, have a Harley-Davidson dealer perform the installation. Improper installation of this kit could result in death or serious injury. (00333a)

⚠ WARNING

Perform this installation when the engine is cool. Working on or near the exhaust system when the engine is hot could result in severe burns. (00311b)

1. Remove the saddlebags if desired for extra working clearance. See SADDLEBAG REMOVAL in the Service Manual.
2. Loosen, but do not remove, the axle nut.
3. Remove the brake caliper following the instructions in the appropriate Service Manual. Do not remove the bracket.

NOTE

On a motorcycle that has been previously serviced, ensure that the axle has not been removed and re-installed from the left side (with the axle nut to the right of the wheel). If it has, the axle MUST be inserted from the right side of the motorcycle.

4. See Figure 1. Remove the axle adjuster bolts (1).

5. Install the new axle adjuster bolts.

⚠ WARNING

Check vehicle alignment according to following procedures. Incorrect alignment can adversely affect stability and handling, which could result in death or serious injury. (00287a)

6. Align the rear wheel. Check that the center of the rear axle is equidistant from the center of the swing arm pivot shaft on each side. The measurements must be equal within 1/32 inch (0.794 mm). Adjust as necessary.
7. Adjust the rear belt tension. See REAR BELT DEFLECTION in the Service Manual.
8. Tighten the axle nut to 129–142 N·m (95–105 ft·lbs).
9. Install the brake caliper following the instructions in the Service Manual.
10. Re-install the saddlebags if removed earlier. See SADDLEBAG INSTALLATION in the Service Manual.

NOTICE

Wipe all fingerprints off of exhaust system components after installation and before starting engine. Oil from hands can leave permanent marks on exhaust system finish. (00346a)

11. Wipe any fingerprints off the exhaust system before starting the engine.

⚠ WARNING

Whenever a wheel is installed and before moving the motorcycle, pump brakes to build brake system pressure. Insufficient pressure can adversely affect brake performance, which could result in death or serious injury. (00284a)

12. Pump the brakes prior to the test ride.
13. Test ride vehicle for proper operation.

is04630

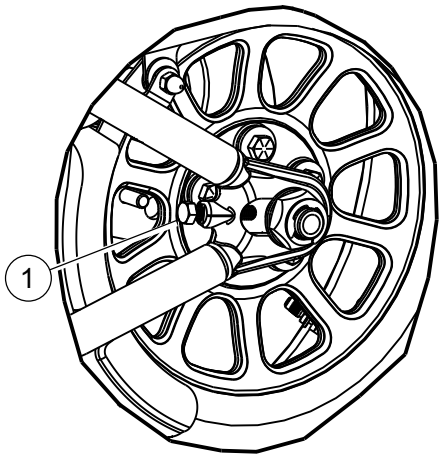

1. Axle adjuster bolt

Figure 1. Rear Axle Hardware (Left Side Shown)

SERVICE PARTS

is04613

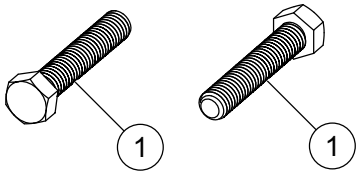

Figure 2. Service Parts: Chrome Rear Axle Adjuster Bolt

Table 1. Service Parts: Chrome Rear Axle Adjuster Bolt

Item	Description (Quantity)	Part Number
1	Bolt, rear axle adjuster (2)	Not Sold Separately