



INSTRUCTIONS

-J04056

REV. 2007-03-15

REAR DISC WHEELS

GENERAL

Kit Number

40829-08, 41026-08, 41260-08, 41261-08, 41262-08, and 41265-08

Models

For model fitment information, please see the P&A Retail Catalog or the Parts and Accessories section of www.harley-davidson.com (English only).

Additional Parts Required

These kits include the custom wheel only.

Proper installation of these kits require the separate purchase of the following parts which are available at a Harley-Davidson dealer.

- Wheel Bearing Remover and Installer (HD-44060)
- Wheel Installation Kit (See tables for part number)

The following Harley-Davidson Genuine Motor Accessories are recommended for proper maintenance and cleaning:

- Harley® Bright™ Chrome Cleaner (94683-99)
- Harley® Glaze™ Polish and Sealant (99701-84)
- Harley® Wheel and Spoke Brush (43078-99)
- Harley-Davidson® Wheel and Tire Cleaner (94658-98)

WARNING

The rider's safety depends upon the correct installation of this kit. Use the appropriate service manual procedures. If the procedure is not within your capabilities or you do not have the correct tools, have a Harley-Davidson dealer perform the installation. Improper installation of this kit could result in death or serious injury. (00333a)

NOTE

This instruction sheet references Service Manual information. A Service Manual for your model motorcycle is required for this installation and is available from a Harley-Davidson dealer.

Kit Contents

See Figure 1 and Service Parts Tables.

INSTALLATION

1. Remove existing rear wheel assembly. Save axle, axle nut, brake disc, and wheel spacers for kit installation. Refer to REAR WHEEL in Service Manual.

NOTES

Prior to removing or installing the wheel, the rear brake caliper must be removed.

The cotter pin or spring clip for the axle nut must be replaced. They are available for purchase from you dealer. See your dealer for the correct part number for your model motorcycle.

CAUTION

Do not re-use brake disc screws. Re-using disc screws can result in torque loss and damage to rotor and/or brake assembly. (00319b)

CAUTION

Do not re-use sprocket mounting screws. Re-using sprocket mounting screws can result in torque loss and damage to the sprocket and/or belt assembly. (00480b)

2. See Figure 1. Install valve stem assembly (E) on wheel. Refer to TIRES in Service Manual.
3. Assemble wheel installation kit components, stock brake disc, and sprocket to wheel using the appropriate service parts table. Refer to REAR WHEEL in Service Manual.

NOTES

Install the primary bearing first using appropriate Service Manual and WHEEL BEARING REMOVER/INSTALLER.

The machined grooves in the hub face indicate the primary bearing side.

4. Install rear wheel (1), stock axle, and stock spacers to motorcycle. Refer to REAR WHEEL in Service Manual.

MAINTENANCE AND CLEANING

Chrome parts must be maintained regularly to ensure that they keep their original shine and luster.

1. Clean heavily-soiled wheel surfaces using Harley-Davidson Wheel and Tire Cleaner, applied with Harley Wheel and Spoke Brush.
2. Thoroughly clean chrome with a good quality chrome cleaner, such as Harley Bright Chrome Cleaner.
3. After cleaning and polishing, seal the finish with a good quality sealer, such as Harley Glaze Polish and Sealant.

SERVICE PARTS

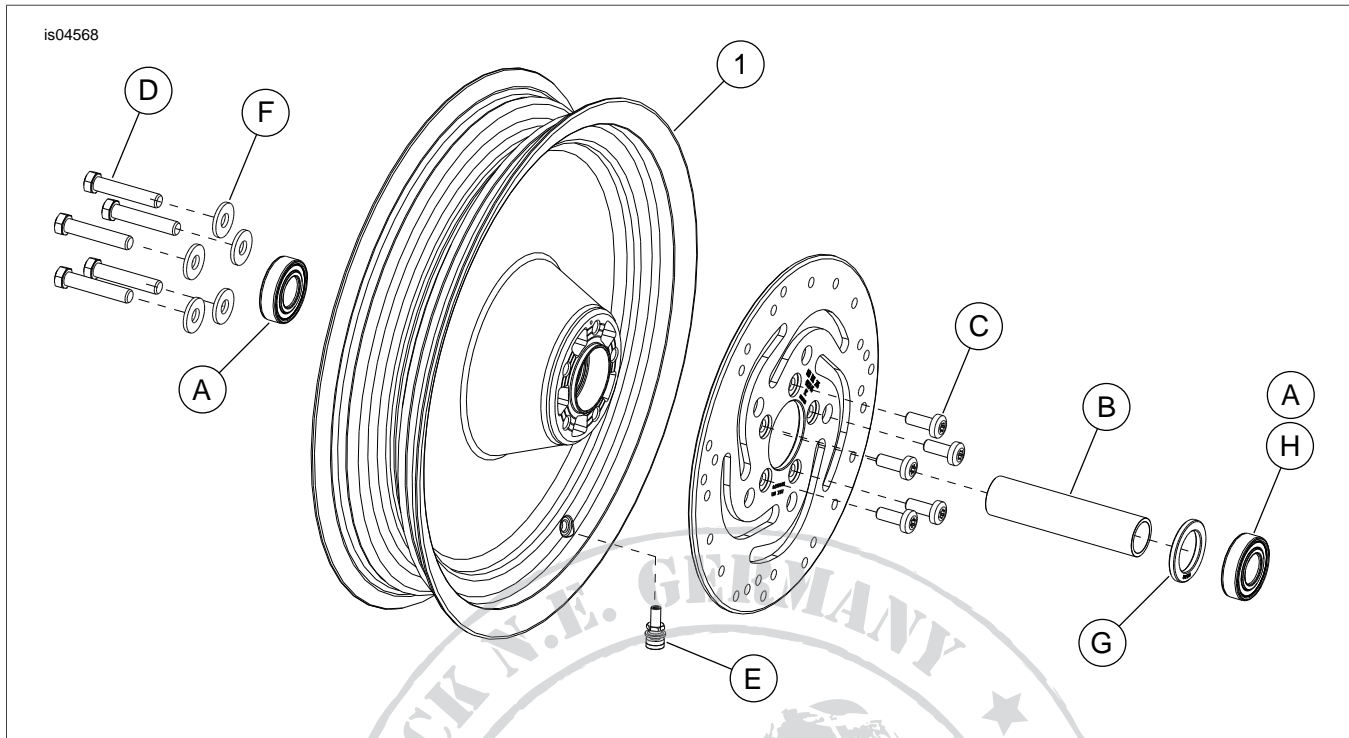

Figure 1. Service Parts: Rear Disc Wheels (16 Inch Shown)

Table 1. Service Parts Table

Kit	Installation Kit	Item	Description (Quantity)	Part Number	
41260-08, 41261-08, 41265-08		1	Wheel	Not Sold Separately	
	Kit 43854-08 Use with 2003-2007 FLST, FLSTN, and FLSTC; 2003-2006 FLSTF (except FLSTFSE2), 2003- 2005 FXST, FXSTB, and FXSTS; 16x3 inch rear wheel.	A	Bearing (2)	9267	
		B	Sleeve, bearing spacer	43608-00	
		C	Disc screw (5)	43567-92	
		D	Sprocket screw (5) (2006 and earlier models)	3737A	
			Sprocket screw (5) (2007 models)	3109	
		E	Valve stem assembly (long)	43206-01	
		F	Washer (5) (2006 and earlier models)	6516HW	
		NOTE: Discard the following components which are provided with this installation kit, but are not required for this fitment.			
			Sleeve, bearing spacer	43618-06	
			Sleeve, bearing spacer	43618-07	
	Sprocket screw (5)	3899			
	Valve stem assembly (short)	43157-83A			

Table 2. Service Parts Table

Kit	Installation Kit	Item	Description (Quantity)	Part Number	
41026-08, 41262-08		1	Wheel	Not Sold Separately	
	Kit 43854-08 Use with 2000-2005 Dyna, 2000-2004 XL, 2000-2002 Softail (except FXSTD), and 2000-2001 FLT; 16x3 inch rear wheel.	A	Bearing (2)	9267	
		B	Sleeve, bearing spacer	43608-00	
		C	Disc screw (5)	43567-92	
		D	Sprocket screw (5) (Dyna and Softail models)		3737A
			Sprocket screw (5) (XL and FLT models)		3899
		E	Valve stem assembly (long)	43206-01	
		F	Washer (5)	6516HW	
		NOTE: Discard the following components which are provided with this installation kit, but are not required for this fitment.			
		Sleeve, bearing spacer			43618-06
		Sleeve, bearing spacer			43618-07
		Sprocket screw (5)			3109
		Valve stem assembly (short)			43157-83A
		Kit 43861-08 Use with 2002-2007 Touring and 2005-2007 XL; 16x3 inch rear wheel.	A	Bearing (2)	9247
			B	Sleeve, bearing spacer	43517-00
	C		Disc screw (5)	43567-92	
	D		Sprocket screw (5) (2004-2006 FLT models)		3737A
			Sprocket screw (5) (2007 FLT models)		3109
			Sprocket screw (5) (XL and 2000-2003 FLT models)		3899
	E		Valve stem assembly (long)	43206-01	
	F		Washer (5) (XL and 2006 and earlier FLT models)	6516HW	
	NOTE: Discard the following components which are provided with this installation kit, but are not required for this fitment.				
	Sleeve, bearing spacer			43704-01	
	Sprocket bolt (5)			3873	
	Sprocket bolt (5)			40439-01	
	Sprocket washer (5)			7039	
	TORX® bolt (5)			4552	
	Valve stem assembly (short)			43157-83A	
	Kit 43878-08 Use with 2008 and later Touring (Non-ABS) and 2008 and later XL; 16x3 inch rear wheel.	A	Bearing (2)	9276	
		B	Sleeve, bearing spacer	41900-08	
		C	Disc screw (5)	43567-92	
		D	Sprocket screw (5) (Touring models)		3814
			Sprocket screw (5) (XL models)		3899
		E	Valve stem assembly (long)	43206-01	
		F	Washer (5) (XL models)	6516HW	
		G	Shim, bearing (install under primary bearing)	43904-08	
		NOTE: Discard the following components which are provided with this installation kit, but are not required for this fitment.			
		Sleeve, bearing spacer			41696-08
	Sprocket screw (5)			3109	
	Valve stem assembly (short)			43157-83A	

Table 2. Service Parts Table

Kit	Installation Kit	Item	Description (Quantity)	Part Number	
	Kit 41453-08 Use with 2008 and later Touring (ABS); 16x3 inch rear wheel.	A	Bearing	9276	
		B	Sleeve, bearing spacer	41900-08	
		C	Disc screw (5)	43567-92	
		D	Sprocket screw (5)	3814	
		E	Valve stem assembly (long)	43206-01	
		G	Shim, bearing (install under primary bearing)	43904-08	
		H	Bearing, ABS (red side must face inward)	9252	
		NOTE: Discard the following components which are provided with this installation kit, but are not required for this fitment.			
			Shim, bearing	41447-08	
			Sleeve, bearing spacer	43704-08	
			TORX bolt (5)	4552	
			Valve stem assembly (short)	43157-83A	
			Washer (5)	7039	

Table 3. Service Parts Table

Kit	Installation Kit	Item	Description (Quantity)	Part Number	
40829-08		1	Wheel	Not Sold Separately	
	Kit 43878-08 Use with 2008 and later FLSTN and FLSTC; 16x3 inch rear wheel.	A	Bearing (2)	9276	
		B	Sleeve, bearing spacer	41696-08	
		C	Disc screw (5)	43567-92	
		D	Sprocket screw (5)	3109	
		E	Valve stem assembly (long)	43206-01	
		NOTE: Discard the following components which are provided with this installation kit, but are not required for this fitment.			
			Shim, bearing	43904-08	
			Sleeve, bearing spacer	41900-08	
			Sprocket screw (5)	3814	
			Sprocket screw (5)	3899	
			Valve stem assembly (short)	43157-83A	
			Washer (5)	6516HW	