



INSTRUCTIONS

-J04027

REV. 2011-06-03

REAR REAPER WHEEL

GENERAL

⚠ WARNING

Install only wheels and installation kits approved for your model motorcycle. Contact a Harley-Davidson dealer to verify fitment. Mismatching wheels and installation kits or installing wheels not approved for your model can cause loss of control, which could result in death or serious injury. (00610c)

Kit Number

40802-08, 40792-09, 41981-08

Models

For model fitment information, see the P&A Retail Catalog or the Parts and Accessories section of www.harley-davidson.com (English only).

Kit Contents

See Figure 1 and Table 2.

Additional Parts Required

Proper installation of these kits require the separate purchase of the following parts which are available at a Harley-Davidson dealer.

- Wheel Installation Kit (See Table 3 through Table 10 to determine required installation kit.)
- Brake Disc Screws (See Table 1 to determine proper hardware.)
- Rear Sprocket Screws (See Table 1 to determine proper hardware.)
- Wheel Bearing Remover and Installer (94134-09A)

The following Harley-Davidson Genuine Motor Accessories are recommended for proper maintenance and cleaning:

- Harley® Bright™ Chrome Cleaner (94683-99)
- Harley® Glaze™ Polish and Sealant (99701-84)
- Harley® Wheel and Spoke Brush (43078-99)
- Harley-Davidson® Wheel and Tire Cleaner (94658-98)
- Harley® Preserve Bare Aluminum Protectant (99845-07)

⚠ WARNING

The rider's safety depends upon the correct installation of this kit. Use the appropriate service manual procedures. If the procedure is not within your capabilities or you do not have the correct tools, have a Harley-Davidson dealer perform the installation. Improper installation of this kit could result in death or serious injury. (00333a)

NOTE

This instruction sheet references service manual information. A service manual for your model motorcycle is required for this installation and is available from a Harley-Davidson dealer.

Table 1. Rear Disc and Sprocket Hardware Fitment

| Hardware | Fitment |
|---|---|
| Rear Disc Screws (select stock or chrome hardware) | |
| 5 Stock disc screws (43567-92) | All models |
| Chrome screw kit (46647-05) includes 5 screws | All models |
| Rear Sprocket Screws (select stock or chrome hardware) | |
| 5 Sprocket screw, stock (3109) | 2007 and later Dyna and Softail, 2007 Touring |
| Chrome screw kit (94773-07) includes 5 screws and washers | 2007 and later Dyna and Softail |
| 5 Sprocket screw, stock (3737A) | 2000-2005 Dyna, 2000-2006 Softail, 2004-2006 Touring |
| Chrome screw kit (94773-00A) includes 5 screws and washers | 2000-2005 Dyna, 2000-2006 Softail |
| 5 Sprocket screw, stock (3814) | 2008 Touring |
| 5 Sprocket screw, stock (3873) | 2006 Dyna |
| 5 Sprocket screw, stock (3899) | 2000-2003 Touring, 2001 and later Sportster (except Japanese models) |
| 5 Sprocket screw, stock (40439-01) | 2002-2006 VRSC and 2007 VRSCR models |
| 5 Sprocket screw, stock (4552) | 2007 and later VRSC models (except VRSCR and VRSCSE models) |
| Rear Sprocket Washers | |
| 5 Sprocket washer, stock (6516HW) | 2006 and earlier Dyna, Softail and Touring and 2000 and later Sportster models (except Japanese models) |
| 5 Sprocket washer, stock (7039) | 2002 and later VRSC |

INSTALLATION

1. Remove existing rear wheel assembly. Save axle, axle nut, brake disc and wheel spacers for kit installation. Refer to REAR WHEEL in service manual.

NOTES

Prior to removing or installing the wheel, the rear brake caliper must be removed. See the appropriate service manual.

The cotter pin or spring clip for the axle nut must be replaced. They are available for purchase from your dealer. See your dealer for the correct part number for your model motorcycle.

NOTE

Install short valve stem (43157-83A) included in the installation kit. Discard all other valve stems.

2. See Figure 1. Install valve stem assembly (H) on wheel following the instructions in the appropriate service manual.

NOTICE

Do not re-use brake disc/rotor screws. Re-using these screws can result in torque loss and damage to brake components. (00319c)

NOTICE

Do not re-use sprocket mounting screws. Re-using sprocket mounting screws can result in torque loss and damage to the sprocket and/or belt assembly. (00480b)

3. Assemble wheel installation kit components, stock brake disc and sprocket to wheel using the appropriate service parts table and following the instructions in the appropriate service manual.

NOTE

The valve stem side of the wheel indicates the primary bearing side. Install the primary bearing first using appropriate service manual and WHEEL BEARING REMOVER/INSTALLER.

For Kits 41981-08: When installing wheel on 2008 and later Dyna models, install bearing shim from installation kit under the primary bearing.

4. Install rear wheel (1), stock axle and stock spacers to motorcycle following the instructions in the appropriate service manual.

MAINTENANCE AND CLEANING

NOTE

This wheel assembly includes plugs that have been installed in the openings between the brake disc mounting holes on one side of the wheel and in the compensator bowl of the 16x5 inch wheel. Missing or damaged plugs can be replaced using Wheel Plug Kit 44459-04 (17x6 inch wheel or 17x4.5 inch wheel) or individual plug 43871-09 (16x5 inch wheel).

Chrome parts must be maintained regularly to keep their original shine and luster.

1. Clean heavily-soiled wheel surfaces using Harley-Davidson Wheel and Tire Cleaner, applied with Harley Wheel and Spoke Brush.
2. Thoroughly clean chrome with a good quality chrome cleaner, such as Harley Bright Chrome Cleaner.
3. After cleaning and polishing, seal the finish with a good quality sealer, such as Harley Glaze Polish and Sealant.



SERVICE PARTS

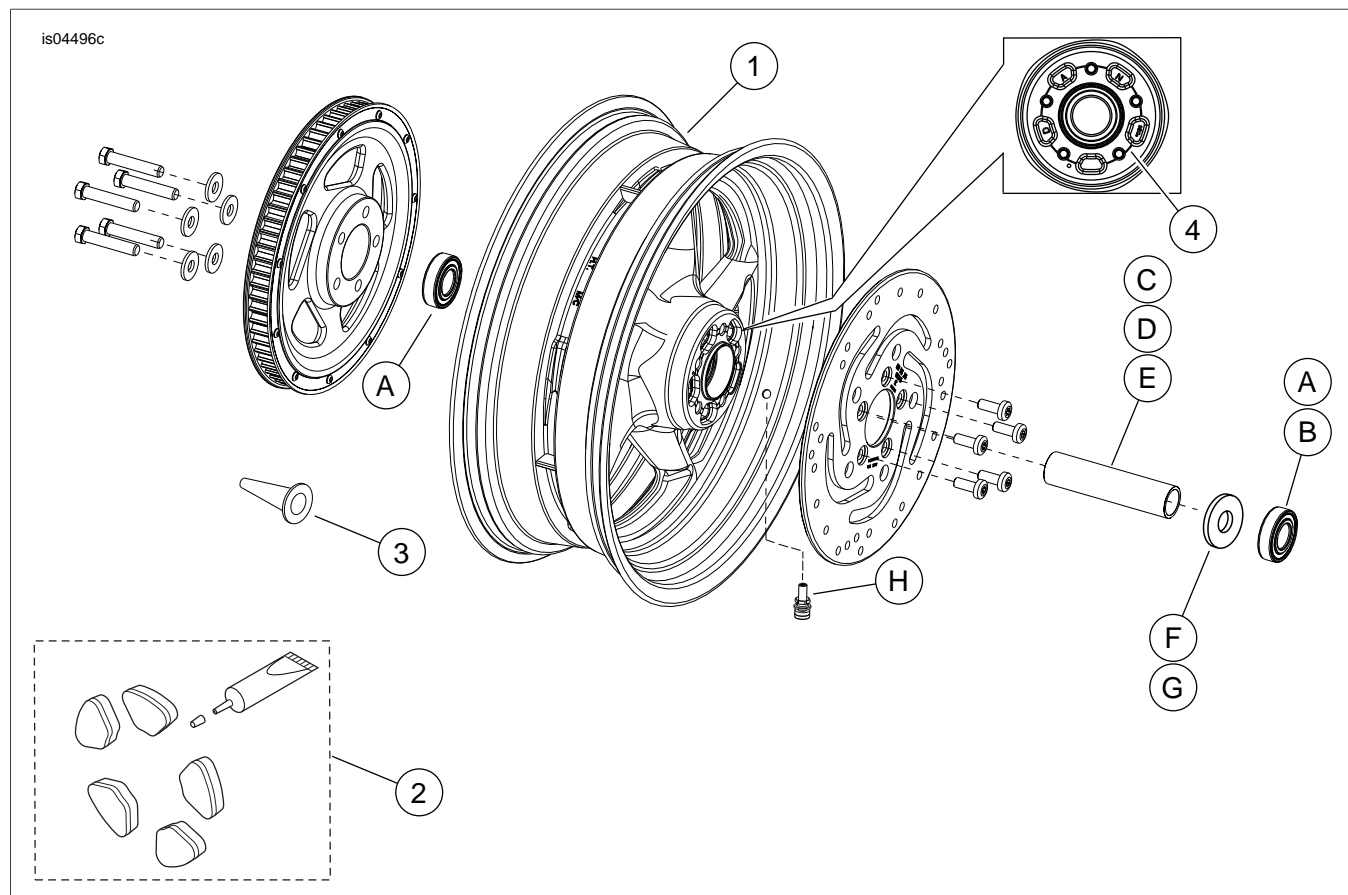

Figure 1. Service Parts: Rear Reaper Wheel

Table 2. Service Parts and Wheel Kit Contents

| Kit | Item | Description (Quantity) | Part Number |
|-------------------------------------|------|------------------------------|---------------------|
| 40802-08, 41981-08 | 1 | Wheel | Not Sold Separately |
| | 2 | Plug service kit | 44459-04 |
| 40792-09 | 1 | Wheel | Not Sold Separately |
| | 3 | Plug | 43871-09 |
| Visual indicator mentioned in text: | | | |
| | 4 | Machined groove (all wheels) | |

Table 3. REAR 3/4 Inch Bearing Wheel Installation Kit (43854-08A)

| REAR 3/4 Inch Bearing Wheel Installation Kit (43854-08A) | | Item (Quantity Used and Description) | | | | | | |
|---|-------------|--------------------------------------|---|---|---|---|---|--|
| Fitment | Wheel Size | A | C | D | E | H | I | |
| 2007 FLST, FLSTN and FLSTC | 16 x 3.0 in | 2 | 1 | 0 | 0 | * | * | |
| 2003-2006 FLST, FLSTN and FLSTC; 2003-2006 FLSTF (except FLSTFSE2); 2003-2005 FXST, FXSTB and FXSTS | 16 x 3.0 in | 2 | 1 | 0 | 0 | * | * | |
| 2000-2005 Dyna; 2000-2002 Softail (except FXSTD) | 16 x 3.0 in | 2 | 1 | 0 | 0 | * | * | |
| 2000-2004 XL; 2000-2001 FLT | 16 x 3.0 in | 2 | 1 | 0 | 0 | * | * | |
| 2000-2007 FXSTD | 17 x 4.5 in | 2 | 1 | 0 | 0 | * | * | |
| 2006 FXST, FXSTB, FXSTS and FLSTFSEi | 17 x 6.0 in | 2 | 0 | 1 | 0 | * | * | |

Table 3. REAR 3/4 Inch Bearing Wheel Installation Kit (43854-08A)

| REAR 3/4 Inch Bearing Wheel Installation Kit (43854-08A) | | Item (Quantity Used and Description) | | | | | |
|---|-------------|--------------------------------------|----------------------|---|-----------|---|---|
| Fitment | Wheel Size | A | C | D | E | H | I |
| 2007 FLSTF, FXST, FXSTB and FXSTC | 17 x 6.0 in | 2 | 0 | 0 | 1 | * | * |
| Installation kits are designed to work with many different wheel styles and fitments. Contact a Harley-Davidson dealer to verify that the wheel and installation kits are both designed and approved for the motorcycle they are being installed on. NOTES: * See NOTE above valve installation step in INSTALLATION to determine which valve stem to use for your particular kit. Discard other valve stem(s). | | A | Bearing, regular (2) | | 9267 | | |
| | | C | Axle sleeve | | 43608-00 | | |
| | | D | Axle sleeve | | 43618-06 | | |
| | | E | Axle sleeve | | 43618-07 | | |
| | | H | Valve stem, short | | 43157-83A | | |
| | | I | Valve stem, long | | 43206-01 | | |

Table 4. REAR 1 Inch Bearing Wheel Installation Kit (43861-08A)

| REAR 1 Inch Bearing Wheel Installation Kit (43861-08A) | | Item (Quantity Used and Description) | | | | |
|---|-------------|--------------------------------------|-------------------|---|-----------|---|
| Fitment | Wheel Size | A | C | D | H | I |
| 2002-2007 FLT; 2005-2007 XL | 16 x 3.0 in | 2 | 1 | 0 | * | * |
| 2006-2007 Dyna | 17 x 4.5 in | 2 | 1 | 0 | * | * |
| 2002-2006 VRSC; 2007 VRSCD and VRSCR | 18 x 5.5 in | 2 | 0 | 1 | * | * |
| 2006 VRSCSEi; 2007 VRSCAW, VRSCX and VRSCDX | 18 x 8.0 in | 2 | 0 | 1 | * | * |
| Installation kits are designed to work with many different wheel styles and fitments. Contact a Harley-Davidson dealer to verify that the wheel and installation kits are both designed and approved for the motorcycle they are being installed on. NOTES: * See NOTE above valve installation step in INSTALLATION to determine which valve stem to use for your particular kit. Discard other valve stem(s). | | A | Bearing, regular | | 9247 | |
| | | C | Axle sleeve | | 43517-00 | |
| | | D | Axle sleeve | | 43704-01 | |
| | | H | Valve stem, short | | 43157-83A | |
| | | I | Valve stem, long | | 43206-01 | |

Table 5. REAR 25 MM Bearing Wheel Installation Kit (41451-08B)

| REAR 25 MM Bearing Wheel Installation Kit (41451-08B) | | Item (Quantity Used and Description) | | | | | |
|---|-----------------------|--------------------------------------|----------------------|----|-----------|---|---|
| Fitment | Wheel Size | A | C | F | H | I | J |
| 2008 and later FXDF | 16 x 5.0 in | 2 | 1 | 0 | * | * | * |
| 2008 and later Dyna (except FXDF) | 17 x 4.5 in | 2 | 1 | ** | * | * | * |
| 2008 and later FXDF | 18 x 6.0 in | 2 | 1 | 0 | * | * | * |
| Installation kits are designed to work with many different wheel styles and fitments. Contact a Harley-Davidson dealer to verify that the wheel and installation kits are both designed and approved for the motorcycle they are being installed on. NOTES: * See NOTE above valve installation step in INSTALLATION to determine which valve stem to use for your particular kit. Discard other valve stem(s). ** See NOTES for your wheel kit above the wheel assembly step in INSTALLATION to determine which bearing shim to use for your particular wheel kit and fitment. *** Bearing shim installed under the primary bearing. | | A | Bearing, regular (2) | | 9276 | | |
| | | C | Axle sleeve | | 43905-08 | | |
| | | F | Bearing shim*** | | 43904-08 | | |
| | | H | Valve stem, short | | 43157-83A | | |
| | | I | Valve stem, long | | 43206-01 | | |
| J | Valve stem, pull-thru | | 40999-87 | | | | |

Table 6. REAR 25mm Bearing Wheel Installation Kit (41456-08C)

| REAR 25 MM Bearing Wheel Installation Kit (41456-08C) | | Item (Quantity Used and Description) | | | | | | | | |
|---|-------------|--------------------------------------|-----------------------|---|---|----|---|---|-----------|--|
| Fitment | Wheel Size | A | C | D | E | F | H | I | J | |
| 2009 and later FLT without ABS | 16 x 5.0 in | 2 | 1 | 0 | 0 | 0 | * | * | * | |
| 2009 and later FLT without ABS | 18 x 5.0 in | 2 | 1 | 0 | 0 | 0 | * | * | 0 | |
| 2008 VRSCD without ABS | 18 x 5.5 in | 2 | 0 | 0 | 1 | ** | * | * | 0 | |
| 2008 and later FXCW and FXCWC without ABS | 18 x 8.0 in | 2 | 0 | 1 | 0 | 0 | * | * | 0 | |
| 2008 and later VRSCAW, VRSCDX and VRSCF without ABS | 18 x 8.0 in | 2 | 0 | 0 | 1 | ** | * | * | 0 | |
| Installation kits are designed to work with many different wheel styles and fitments. Contact a Harley-Davidson dealer to verify that the wheel and installation kits are both designed and approved for the motorcycle they are being installed on. NOTES: * See NOTE above valve installation step in INSTALLATION to determine which valve stem to use for your particular kit. Discard other valve stem(s). ** See INSTALLATION to determine if shim is required. *** Bearing shim installed under primary bearing. | | A | Bearing, regular (2) | | | | | | 9276 | |
| | | C | Axle sleeve | | | | | | 41349-07 | |
| | | D | Axle sleeve | | | | | | 41358-08 | |
| | | E | Axle sleeve | | | | | | 43704-08 | |
| | | F | Bearing shim*** | | | | | | 41447-08 | |
| | | H | Valve stem, short | | | | | | 43157-83A | |
| | | I | Valve stem, long | | | | | | 43206-01 | |
| | | J | Valve stem, pull thru | | | | | | 40999-87 | |

Table 7. REAR 25mm Bearing Wheel Installation Kit (43878-08B)

| REAR 25 MM Bearing Wheel Installation Kit (43878-08B) | | Item (Quantity Used and Description) | | | | | | | | |
|---|-------------|--------------------------------------|-----------------------|---|----|---|---|---|-----------|--|
| Fitment | Wheel Size | A | C | D | F | H | I | J | | |
| 2008 and later FLSTN, FLSTC and FXS without ABS | 16 x 3.0 in | 2 | 1 | 0 | 0 | * | * | 0 | | |
| 2008 FLT without ABS | 16 x 3.0 in | 2 | 0 | 1 | 1 | * | * | 0 | | |
| 2008 and later XL (except 2011 and later XL883L) | 16 x 3.0 in | 2 | 0 | 1 | ** | * | * | * | | |
| 2008 and later FXSTB, FXSTC, FLSTF, FLSTSB and FLSTFB without ABS | 17 x 6.0 in | 2 | 1 | 0 | 0 | * | * | 0 | | |
| 2008 and later FXSTB, FXSTC, FLSTF, FLSTSB and FLSTFB without ABS | 18 x 6.0 in | 2 | 1 | 0 | 0 | * | * | 0 | | |
| Installation kits are designed to work with many different wheel styles and fitments. Contact a Harley-Davidson dealer to verify that the wheel and installation kits are both designed and approved for the motorcycle they are being installed on. NOTES: * See NOTE above valve installation step in INSTALLATION to determine which valve stem to use for your particular kit. Discard other valve stem(s). ** See NOTES for your wheel kit above the wheel assembly step in INSTALLATION to determine which bearing shim to use for your particular wheel kit and fitment. *** Bearing shim installed under primary bearing. | | A | Bearing, regular (2) | | | | | | 9276 | |
| | | C | Axle sleeve | | | | | | 41696-08 | |
| | | D | Axle sleeve | | | | | | 41900-08 | |
| | | F | Bearing shim*** | | | | | | 43904-08 | |
| | | H | Valve stem, short | | | | | | 43157-83A | |
| | | I | Valve stem, long | | | | | | 43206-01 | |
| | | J | Valve stem, pull thru | | | | | | 40999-87 | |

Table 8. REAR 25 MM Bearing ABS Wheel Installation Kit (41453-08C)

| REAR 25 MM Bearing ABS Wheel Installation Kit (41453-08C) | | Item (Quantity Used and Description) | | | | | | | | | | |
|---|-------------|--------------------------------------|---|---|---|---|----|---|---|---|---|--|
| Fitment | Wheel Size | A | B | C | D | E | F | G | H | I | J | |
| 2008 FLT with ABS | 16 x 3.0 in | 1 | 1 | 0 | 1 | 0 | 0 | 1 | * | * | 0 | |
| 2009 and later FLT with ABS | 16 x 5.0 in | 1 | 1 | 1 | 0 | 0 | 0 | 0 | * | * | * | |
| 2009 and later FLT with ABS | 18 x 5.0 in | 1 | 1 | 1 | 0 | 0 | 0 | 0 | * | * | 0 | |
| 2008 VRSCDa with ABS | 18 x 5.5 in | 1 | 1 | 0 | 0 | 1 | ** | 0 | * | * | 0 | |

Table 8. REAR 25 MM Bearing ABS Wheel Installation Kit (41453-08C)

| REAR 25 MM Bearing ABS Wheel Installation Kit (41453-08C) | | Item (Quantity Used and Description) | | | | | | | | | |
|---|-------------|--------------------------------------|-----------------------|---|---|---|----|---|---|-----------|---|
| Fitment | Wheel Size | A | B | C | D | E | F | G | H | I | J |
| 2008 and later VRSCAWa, VRSCDXa, VRSCXa and VRSCFa with ABS | 18 x 8.0 in | 1 | 1 | 0 | 0 | 1 | ** | 0 | * | * | 0 |
| Installation kits are designed to work with many different wheel styles and fitments. Contact a Harley-Davidson dealer to verify that the wheel and installation kits are both designed and approved for the motorcycle they are being installed on. NOTES: * See NOTE above valve installation step in INSTALLATION to determine which valve stem to use for your particular kit. Discard other valve stem(s). ** Primary bearing. Bearing must be installed with red side facing the wheel. *** Bearing shim installed under primary bearing. | | A | Bearing, regular | | | | | | | 9276 | |
| | | B | Bearing, ABS** | | | | | | | 9252 | |
| | | C | Axle sleeve | | | | | | | 41349-07 | |
| | | D | Axle sleeve | | | | | | | 41900-08 | |
| | | E | Axle sleeve | | | | | | | 43704-08 | |
| | | F | Bearing shim*** | | | | | | | 41447-08 | |
| | | G | Bearing shim*** | | | | | | | 43904-08 | |
| | | H | Valve stem, short | | | | | | | 43157-83A | |
| | | I | Valve stem, long | | | | | | | 43206-01 | |
| | | J | Valve stem, pull thru | | | | | | | 40999-87 | |

Table 9. REAR 25 MM Bearing ABS Wheel Installation Kit (43077-11)

| REAR 25 MM Bearing ABS Wheel Installation Kit (43077-11) | | Item (Quantity Used and Description) | | | | | | |
|--|-------------|--------------------------------------|-------------------|---|---|---|-----------|--|
| Fitment | Wheel Size | A | B | C | D | H | I | |
| 2011 and later FLSTN, FLSTC and FXS with ABS | 16 x 3.0 in | 1 | 1 | 0 | 1 | * | * | |
| 2011 and later FXST, FLSTF and FLSTFB with ABS | 17 x 6.0 in | 1 | 1 | 0 | 1 | * | * | |
| 2011 and later FXST, FLSTF and FLSTFB with ABS | 18 x 6.0 in | 1 | 1 | 0 | 1 | * | * | |
| 2011 and later FXCWC with ABS | 18 x 8.0 in | 1 | 1 | 1 | 0 | * | * | |
| Installation kits are designed to work with many different wheel styles and fitments. Contact a Harley-Davidson dealer to verify that the wheel and installation kits are both designed and approved for the motorcycle they are being installed on. NOTES: * See NOTE above valve installation step in INSTALLATION to determine which valve stem to use for your particular kit. Discard other valve stem(s). ** Primary bearing. Bearing must be installed with red side facing the wheel. | | A | Bearing, regular | | | | 9276 | |
| | | B | Bearing, ABS** | | | | 9252 | |
| | | C | Axle sleeve | | | | 41358-08 | |
| | | D | Axle sleeve | | | | 41696-08 | |
| | | H | Valve stem, short | | | | 43157-83A | |
| | | I | Valve stem, long | | | | 43206-01 | |

Table 10. REAR 25 MM Bearing ABS Wheel Installation Kit (42400003)

| REAR 25 MM Bearing ABS Wheel Installation Kit (42400003) | | Item (Quantity Used and Description) | | | | | | | | | |
|--|-------------|--------------------------------------|-----------------------|---|---|---|---|---|--|-----------|--|
| Fitment | Wheel Size | A | B | C | F | H | I | J | | | |
| 2008 and later FXDF | 16 x 5.0 in | 1 | 1 | 1 | 0 | * | * | * | | | |
| 2008 and later Dyna (except FXDF and FLD) | 17 x 4.5 in | 1 | 1 | 1 | 1 | * | * | * | | | |
| 2012 FLD | 17 x 4.5 in | 1 | 1 | 1 | 0 | * | * | * | | | |
| 2008 and later FXDF | 18 x 6.0 in | 1 | 1 | 1 | 0 | * | * | * | | | |
| Installation kits are designed to work with many different wheel styles and fitments. Contact a Harley-Davidson dealer to verify that the wheel and installation kits are both designed and approved for the motorcycle they are being installed on. NOTES: * See NOTE above valve installation step in INSTALLATION to determine which valve stem to use for your particular kit. Discard other valve stem(s). ** Primary bearing. Bearing must be installed with red side facing the wheel. | | A | Bearing, regular | | | | | | | 9276 | |
| | | B | Bearing, ABS** | | | | | | | 9252 | |
| | | C | Axle sleeve | | | | | | | 43905-08 | |
| | | F | Bearing shim | | | | | | | 43904-08 | |
| | | H | Valve stem, short | | | | | | | 43157-83A | |
| | | J | Valve stem, pull-thru | | | | | | | 40999-87 | |