



INSTRUCTIONS

-J04052

REV. 2009-01-27

FRONT REAPER WHEEL KITS

GENERAL

Kit Numbers

40778-08, 40790-09, 40779-08, 41983-08

Models

For model fitment information, see the P&A Catalog or the Parts and Accessories section of www.harley-davidson.com (English only).

NOTE

Accessory hub caps are not compatible with this wheel.

Additional Parts Required

These kits include the custom wheel only. Some kits also include a hub cap. The wheel installation kit must be purchased separately from a Harley-Davidson dealer. Refer to the Service Parts page for a complete description and part numbers for these items.

Proper installation of this kit requires the separate purchase of the following parts which are available at a Harley-Davidson dealer:

- Wheel Bearing Remover and Installer (HD-44060-A)
- Wheel Installation Kit (See Service Parts Tables for part number)
- **For Kit 40790-09** on 2004-2008 Touring models, separate purchase of tire 43371-07 is required. For 2009 and later models, tire 44026-09 is required.
- **For Kit 40790-09** on 2004-2007 models, separate purchase of (2) 44343-01 brake rotors is required. For 2008-later models the separate purchase of (2) 44553-06A brake rotors is required.
- **For Kit 41983-08** on 2006-Later Dyna models (except FXDWG and FXDF), separate purchase of brake disc 44553-06A is required if installing the wheel on a motorcycle with stock laced wheel.

Recommended Parts

It is recommended that a floating brake rotor for kit 40779-08 be purchased separately if objectionable brake noise is experienced from the brake rotors. Refer to the P&A Catalog or the Parts and Accessories section of www.harley-davidson.com for part numbers.

The following Harley-Davidson Genuine Motor Accessories are recommended for proper maintenance and cleaning:

- Harley® Bright™ Chrome Cleaner (94683-99)
- Harley® Glaze™ Polish and Sealant (99701-84)
- Harley® Wheel and Spoke Brush (43078-99)
- Harley-Davidson® Wheel and Tire Cleaner (94658-98)

⚠ WARNING

The rider's safety depends upon the correct installation of this kit. Use the appropriate service manual procedures. If the procedure is not within your capabilities or you do not have the correct tools, have a Harley-Davidson dealer perform the installation. Improper installation of this kit could result in death or serious injury. (00333a)

NOTE

This instruction sheet references service manual information. A service manual for your model motorcycle is required for this installation and is available from a Harley-Davidson dealer.

Kit Contents

See the Service Parts section for kit contents.

INSTALLATION

1. Remove existing front wheel assembly. Save axle, axle nut, brake disc and wheel spacers for kit installation.
For FXSTD Models: Discard tapered spacer. Refer to FRONT WHEEL in service manual.
2. See Figure 1. Install valve stem assembly (D) on wheel. Refer to TIRES in service manual.

CAUTION

Do not re-use brake disc/rotor screws. Re-using these screws can result in torque loss and damage to brake components. (00319c)

NOTES

Install the primary bearing first using appropriate service manual and WHEEL BEARING REMOVER/INSTALLER.

For Kit 40778-08:

- *The right side of the wheel has DOT markings.*
- **For 2006 and earlier FX Softail Models and 2007 and earlier FXDWG Models:** *The right side of the wheel is the primary bearing side.*
- **For 2007 and later FX Softail Models:** *The left side of the wheel is the primary bearing side.*
- **For FXSTS models:** *The right side is the brake disc side.*
- **For all other models:** *The left side is the brake disc side.*

For Kit 40779-08 and 40790-09:

- *The left side of the wheel has cast-in markings in the hub pockets to identify it as the disc side and primary bearing side for installation.*

For Kit 41983-08:

- *The left side of the wheel with the brake disc mounting tower and cast-in markings is the primary bearing side of the wheel.*
- 3. Assemble wheel installation kit components and brake disc(s) to wheel, using the appropriate service parts table. Refer to FRONT WHEEL in service manual.
- 4. **For FXSTD Models:** Install wheel kit and wheel spacer provided in installation kit in place of the tapered right side spacer discarded in Step 1. Refer to FRONT WHEEL in service manual.
For FXSTS Models: Install the spacer provided in the installation kit between the stock left side spacer and the left fork.
For all other models: Install previously removed wheel spacers. Refer to FRONT WHEEL in service manual.
- 5. Install front wheel (1), stock axle and stock axle nut. Refer to FRONT WHEEL in service manual.

MAINTENANCE AND CLEANING

NOTE

Some wheel assemblies include plugs that have been installed in the openings between the brake disc mounting holes on one side of the wheel. Missing or damaged plugs can be replaced using the Wheel Plug Kit (44459-04).

Chrome parts must be maintained regularly to keep their original shine and luster.

1. Clean heavily-soiled wheel surfaces using Harley-Davidson Wheel and Tire Cleaner, applied with the Harley Wheel and Spoke Brush.
2. Thoroughly clean chrome with a good quality chrome cleaner, such as Harley Bright Chrome Cleaner.
3. After cleaning and polishing, seal the finish with a good quality sealer, such as Harley Glaze Polish and Sealant.



SERVICE PARTS

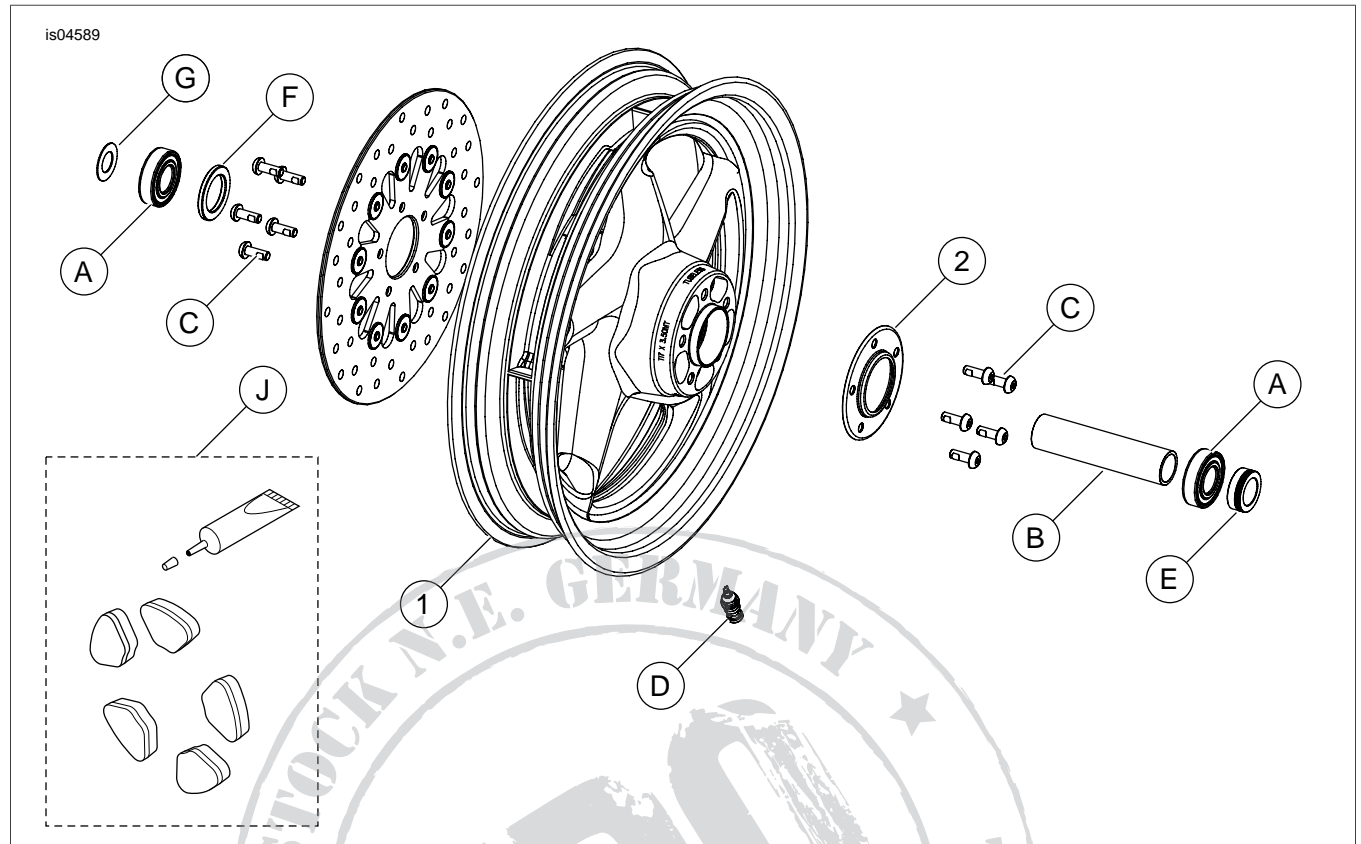

Figure 1. Front Reaper Wheel (21-inch wheel shown)

Table 1. Service Parts Table

Kit	Installation Kit	Item	Description (Quantity)	Part Number	
40779-08		1	Wheel	Not Sold Separately	
		2	Hub cap	43986-00	
		J	Plug Service Kit	44459-04	
Items requiring separate purchase:					
2008 and later FLSTF Models	43851-08 Front 17x3.5 inch Fitment	A	Bearing (2)	9276	
		B	Sleeve, bearing spacer	41349-07	
		C	Screw (10)	3655A	
		D	Valve stem	43157-83A	
		Discard the following components which are provided with this installation kit, but are not required for this fitment.			
			Shim, bearing	43315-07	
			Sleeve, bearing spacer	41900-08	
			Spacer, axle	41695-07	
			Spacer, axle	41504-07	
			Valve stem	43206-01	
	Shim, bearing	43903-08			

Table 2. Service Parts Table

Kit	Installation Kit	Item	Description (Quantity)	Part Number	
40778-08		1	Wheel	Not Sold Separately	
		2	Hub cap	43986-00	
		J	Plug Service Kit	44459-04	
		Items requiring separate purchase:			
2000-2006 FX Softail (except FXSTDSE) and 2000-2005 FXDWG Models <ul style="list-style-type: none"> For FXSTS models: Install spacer (43313-98) on the left side of the vehicle between the stock wheel spacer and fork. For FXSTD Models: Wheel spacer (40910-00A) is included to replace the tapered spacer 	43833-07 Front 21x2.15 inch Fitment	A	Bearing (2)	9267	
		B	Sleeve, bearing spacer	43536-00	
		C	Screws (10)	3655A	
		D	Valve stem	43157-83A	
		E	Spacer, axle (FXSTD only)	40910-00A	
		G	Spacer, axle (FXSTS only)	43313-98	
		Discard the following components which are provided with this installation kit but are not required for this fitment.			
		Sleeve, bearing spacer			43608-00
		Sleeve, bearing spacer			43613-00
		Valve stem			43206-01
		Spacer, axle			43617-00A
		2006-2007 FXDWG Models	43848-08 Front 21x2.15 inch Fitment	A	Bearing (2)
B	Sleeve, bearing spacer			43633-06	
C	Screws (10)			3655A	
D	Valve stem			43157-83A	
Discard the following components which are provided with this installation kit, but are not required for this fitment.					
Spacer, axle				43517-00	
Sleeve, bearing spacer				43755-04	
Sleeve, bearing spacer				43641-01	
Screws, TORX® (10)				3762M	
Washers (10)				6966M	
Valve stem				43206-01	
2007 and later FXST, FXSTB, FXSTC and FXSTD Models <ul style="list-style-type: none"> For 2007 and later FXSTD Models: Wheel spacer (41504-07) is included to replace the tapered spacer. The left side of the wheel is the primary bearing side for this fitment. 	43851-08 Front 21x2.15 inch Fitment			A	Bearing (2)
		B	Sleeve, bearing spacer	41349-07	
		C	Screws (10)	3655A	
		D	Valve stem	43157-83A	
		E	Spacer, axle (FXSTD only)	41504-07	
		F	Shim, bearing (install under primary [left side] bearing)	43315-07	
		Discard the following components which are provided with this installation kit, but are not required for this fitment.			
		Shim, bearing			43903-08
		Sleeve, bearing spacer			41900-08
		Spacer, axle			41695-07
		Valve stem			43206-01

Table 3. Service Parts Table

Kit	Installation Kit	Item	Description (Quantity)	Part Number	
40790-09		1	Wheel	Not Sold Separately	
Items requiring separate purchase:					
2004-2007 Touring Models	43848-08 Front 18x3.5 inch Fitment	A	Bearing (2)	9247	
		B	Sleeve, bearing spacer	43517-00	
		C	Screw, TORX® (10)	3762M	
		D	Valve stem	43157-83A	
		E	Washer (10)	6966M	
		Discard the following components which are provided with this installation kit, but are not required for this fitment.			
		Screw (10)			3655A
		Sleeve, bearing spacer			43633-06
		Sleeve, bearing spacer			43641-01
		Sleeve, bearing spacer			43755-04
Valve stem			43206-01		
2008-later Touring Models without ABS (except FLHTCUTG)	41455-08A Front 18x3.5 inch Fitment	A	Bearing (2)	9276	
		B	Sleeve, bearing spacer	41900-08	
		C	Screw, TORX (10)	3762M	
		D	Valve stem	43157-83A	
		E	Washer (10)	6966M	
		F	Shim, bearing (install under primary bearing)	43903-08	
		Discard the following components which are provided with this installation kit, but are not required for this fitment.			
		Sleeve, bearing spacer			41748-08
		Shim, bearing			41450-08
		Valve stem			43206-01
Screw (10)			3655A		
2008-later Touring Models with ABS (except FLHTCUTG)	41454-08 Front 18x3.5 inch Fitment	A	Bearing	9276	
		B	Sleeve, bearing spacer	41900-08	
		C	Screw, TORX (10)	3762M	
		D	Valve stem	43157-83A	
		E	Washer (10)	6966M	
		F	Shim, bearing (install under primary bearing)	43903-08	
		H	Bearing, ABS (red side must face inward)	9252	
		Discard the following components which are provided with this installation kit, but are not required for this fitment.			
		Sleeve, bearing spacer			41748-08
		Shim, bearing			41450-08
Valve stem			43206-01		
Screw (10)			3655A		

Table 4. Service Parts Table

Kit	Installation Kit	Item	Description (Quantity)	Part Number
41983-09		1	Wheel	Not Sold Separately
Items requiring separate purchase:				
2006-2007 Dyna Models (except FXDWG)	43848-08 Front 19x2.5 inch Fitment	A	Bearing (2)	9247
		B	Sleeve, bearing spacer	43641-01
		C	Screw, TORX® (5)	3762M
		D	Valve stem	43157-83A
		E	Washer (5)	6966M
		Discard the following components which are provided with this installation kit, but are not required for this fitment.		
	Screw (10)			3655A
	Sleeve, bearing spacer			43633-06
	Sleeve, bearing spacer			43517-00
	Sleeve, bearing spacer			43755-04
	Screw, TORX (5)			3762M
	Washer (5)			6966M
	Valve stem			43206-01
	2008-later Dyna Models (except FXDWG and FXDF)	41455-08A Front 19x2.5 inch Fitment	A	Bearing (2)
B			Sleeve, bearing spacer	41748-08
C			Screw, TORX (5)	3762M
D			Valve stem	43157-83A
E			Washer (5)	6966M
F			Shim, bearing (install under primary bearing)	41450-08
Discard the following components which are provided with this installation kit, but are not required for this fitment.				
Sleeve, bearing spacer			41900-08	
Shim, bearing			43903-08	
Screw (10)			3655A	
Valve stem			43206-01	