



INSTRUCTIONS

-J04943

REV. 2011-06-03

REAR SWITCHBLADE WHEELS

GENERAL

WARNING

Install only wheels and installation kits approved for your model motorcycle. Contact a Harley-Davidson dealer to verify fitment. Mismatching wheels and installation kits or installing wheels not approved for your model can cause loss of control, which could result in death or serious injury. (00610c)

Kit Number

40386-10

Kit Contents

See Figure 1 and the Service Parts Tables.

Models

For model fitment information, see the P&A Retail Catalog or the Parts and Accessories section of www.harley-davidson.com (English only).

Additional Parts Required

Proper installation of this kit requires the separate purchase of the following parts which are available at a Harley-Davidson dealer:

- Wheel Installation Kit (See Table 3 through Table 4 to determine required installation kit.)
- Brake Disc Screws (See Table 1 to determine proper hardware.)
- Rear Sprocket Screws (See Table 1 to determine proper hardware.) See the P&A Retail Catalog for chrome sprocket hardware.
- Wheel Bearing Remover and Installer (94134-09A)

WARNING

The rider's safety depends upon the correct installation of this kit. Use the appropriate service manual procedures. If the procedure is not within your capabilities or you do not have the correct tools, have a Harley-Davidson dealer perform the installation. Improper installation of this kit could result in death or serious injury. (00333a)

NOTE

This instruction sheet references service manual information. A service manual for your model motorcycle is required for this installation and is available from a Harley-Davidson dealer.

Recommended Additional Parts

It is recommended that a floating brake rotor be purchased separately if objectionable brake noise is experienced from the

brake rotors. Refer to the P&A Retail Catalog or the Parts and Accessories section of www.harley-davidson.com (English only).

The following Harley-Davidson Genuine Motor Accessories are recommended for proper maintenance and cleaning:

- Harley® Bright™ Chrome Cleaner (94683-99)
- Harley® Glaze™ Polish and Sealant (99701-84)
- Harley® Wheel and Spoke Brush (43078-99)
- Harley-Davidson® Wheel and Tire Cleaner (94658-98)
- Harley® Preserve Bare Aluminum Protectant (99845-07)

Table 1. Rear Disc and Sprocket Hardware Fitment

Hardware	Fitment
Rear Disc Screws (select stock or chrome hardware)	
5 Stock disc screws (43567-92)	All models
Chrome screw kit (46647-05) includes 5 screws	All models
Rear Sprocket Screws (select stock or chrome hardware)	
5 Sprocket screw, stock (3109)	2007 and later Dyna and Softail, 2007 Touring
Chrome screw kit (94773-07) includes 5 screws and washers	2007 and later Dyna and Softail
5 Sprocket screw, stock (3737A)	2000-2005 Dyna, 2000-2006 Softail, 2004-2006 Touring
Chrome screw kit (94773-00A) includes 5 screws and washers	2000-2005 Dyna, 2000-2006 Softail
5 Sprocket screw, stock (3814)	2008 Touring
5 Sprocket screw, stock (3873)	2006 Dyna
5 Sprocket screw, stock (3899)	2000-2003 Touring, 2001 and later Sportster (except Japanese models)
5 Sprocket screw, stock (40439-01)	2002-2006 VRSC and 2007 VRSCR models
5 Sprocket screw, stock (4552)	2007 and later VRSC models (except VRSCR and VRSCSE models)
Rear Sprocket Washers	
5 Sprocket washer, stock (6516HW)	2006 and earlier Dyna, Softail and Touring and 2000 and later Sportster models (except Japanese models)
5 Sprocket washer, stock (7039)	2002 and later VRSC

INSTALLATION

NOTE

Before removing or installing the wheel, the rear brake caliper must be removed. The cotter pin or spring clip for the axle nut must be replaced. They are available for separate purchase from a Harley-Davidson dealer. See dealer for the correct part number.

1. Remove existing rear wheel assembly. Save axle, axle nut, brake disc and wheel spacers for kit installation. Refer to the service manual.

NOTE

Install short valve stem (43157-83A) included in the installation kit. Discard all other valve stems.

2. See Figure 1. Install valve stem assembly (H) on wheel. Refer to the service manual.

NOTICE

Do not re-use brake disc/rotor screws. Re-using these screws can result in torque loss and damage to brake components. (00319c)

NOTICE

Do not re-use sprocket mounting screws. Re-using sprocket mounting screws can result in torque loss and damage to the sprocket and/or belt assembly. (00480b)

3. Assemble wheel installation kit components, brake disc and sprocket to wheel, using the appropriate service parts table. Refer to the service manual.
4. Install primary bearing with a Wheel Bearing Remover and Installer. Refer to the service manual. The hub face with the double machined grooves indicates the primary bearing side.
5. Install rear wheel (1), stock axle, sprocket and stock spacers to motorcycle. See the service manual.

MAINTENANCE AND CLEANING

Chrome parts must be maintained regularly so they keep their original shine and luster.

1. Clean heavily-soiled wheel surfaces using Harley-Davidson Wheel and Tire Cleaner, applied with Harley Wheel and Spoke Brush.
2. Thoroughly clean chrome with a good quality chrome cleaner, such as Harley Bright Chrome Cleaner.
3. After cleaning and polishing, seal the finish with a good quality sealer, such as Harley Glaze Polish and Sealant.



SERVICE PARTS

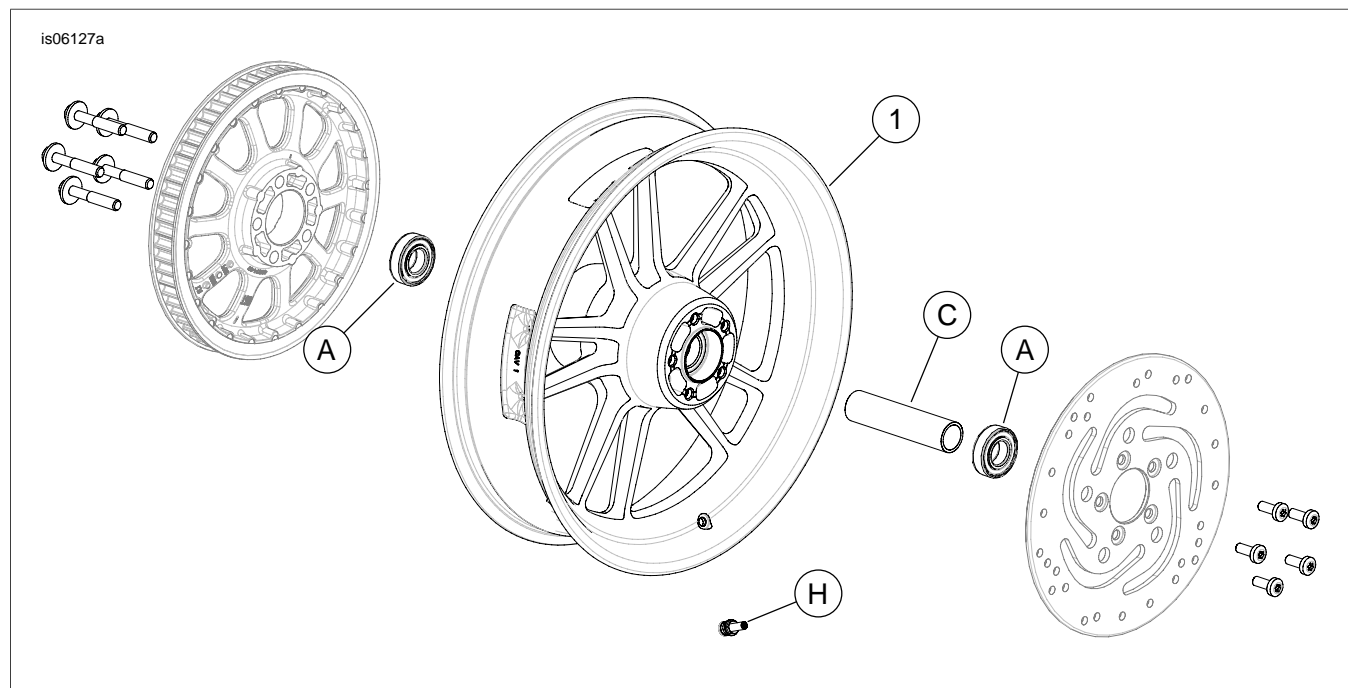

Figure 1. Service Parts: Rear Switchblade Wheel (17 inch shown)

Table 2. Service Parts and Wheel Kit Contents

Kit	Item	Description (Quantity)	Part Number
40386-10	1	Wheel	Not Sold Separately

Table 3. REAR 25 MM Bearing Wheel Installation Kit (41451-08B)

REAR 25 MM Bearing Wheel Installation Kit (41451-08B)		Item (Quantity Used and Description)						
Fitment	Wheel Size	A	C	F	H	I	J	
2008 and later FXDF	16 x 5.0 in	2	1	0	*	*	*	
2008 and later Dyna (except FXDF)	17 x 4.5 in	2	1	**	*	*	*	
2008 and later FXDF	18 x 6.0 in	2	1	0	*	*	*	
Installation kits are designed to work with many different wheel styles and fitments. Contact a Harley-Davidson dealer to verify that the wheel and installation kits are both designed and approved for the motorcycle they are being installed on.		A	Bearing, regular (2)		9276			
NOTES:		C	Axle sleeve		43905-08			
* See NOTE above valve installation step in INSTALLATION to determine which valve stem to use for your particular kit. Discard other valve stem(s).		F	Bearing shim***		43904-08			
** See NOTES for your wheel kit above the wheel assembly step in INSTALLATION to determine which bearing shim to use for your particular wheel kit and fitment.		H	Valve stem, short		43157-83A			
*** Bearing shim installed under the primary bearing.		I	Valve stem, long		43206-01			
		J	Valve stem, pull-thru		40999-87			

Table 4. REAR 25 MM Bearing ABS Wheel Installation Kit (42400003)

REAR 25 MM Bearing ABS Wheel Installation Kit (42400003)		Item (Quantity Used and Description)						
Fitment	Wheel Size	A	B	C	F	H	I	J
2008 and later FXDF	16 x 5.0 in	1	1	1	0	*	*	*
2008 and later Dyna (except FXDF and FLD)	17 x 4.5 in	1	1	1	1	*	*	*

Table 4. REAR 25 MM Bearing ABS Wheel Installation Kit (42400003)

REAR 25 MM Bearing ABS Wheel Installation Kit (42400003)		Item (Quantity Used and Description)						
Fitment	Wheel Size	A	B	C	F	H	I	J
2012 FLD	17 x 4.5 in	1	1	1	0	*	*	*
2008 and later FXDF	18 x 6.0 in	1	1	1	0	*	*	*
Installation kits are designed to work with many different wheel styles and fitments. Contact a Harley-Davidson dealer to verify that the wheel and installation kits are both designed and approved for the motorcycle they are being installed on. NOTES: * See <i>NOTE</i> above valve installation step in INSTALLATION to determine which valve stem to use for your particular kit. Discard other valve stem(s). ** Primary bearing. Bearing must be installed with red side facing the wheel.		A	Bearing, regular				9276	
		B	Bearing, ABS**				9252	
		C	Axle sleeve				43905-08	
		F	Bearing shim				43904-08	
		H	Valve stem, short				43157-83A	
		J	Valve stem, pull-thru				40999-87	

