



INSTRUCTIONS

-J01674

REV. 2006-09-07

BILLET STYLE REAR BRAKE LEVER KIT

GENERAL

Kit Number

42632-00, 42632-07

Models

For model fitment information, please see the P&A Retail Catalog or the Parts and Accessories section of www.harley-davidson.com (English only).

Additional Parts Required

Proper installation of this kit also requires installing a Brake Pedal Pad, sold separately. Refer to the appropriate Parts Catalog for a stock replacement rubber pad or see the current Harley-Davidson Genuine Motor Accessories and Parts catalog for a selection of brake pedal pads.

NOTE

A Service Manual for your model motorcycle is available from a Harley-Davidson Dealer.

Kit Contents

See Figure 1 and Table 1.

INSTALLATION

Removing the Stock Brake Lever

1. See Figure 1. Remove the cotter pin and washer from the master cylinder clevis pin. Discard the cotter pin.

NOTE

The clevis pin has a slight interference fit. It may be necessary to use pliers to pull the clevis pin from the push rod. Be careful not to damage mating parts.

2. Remove the clevis pin from the brake rod. Thoroughly clean and examine parts for wear. Replace if necessary.
3. Remove the brake lever mounting screw and flat washer, and save for reinstallation. Remove and discard the outer O-Ring.

4. Remove the brake lever by rotating counter-clockwise and lifting the master-cylinder clevis if necessary. Pull the lever from the shaft. Remove and discard the inner O-Ring.
5. Thoroughly clean the lever mounting shaft of grease and dirt.

Installing the New Brake Lever

NOTE

This Billet-Style Brake Lever is equipped with self-lubricating bushings. It is not necessary to lubricate the mounting shaft or bushings inside the lever prior to installation.

1. Install the new billet style brake lever (1) onto the mounting shaft.
2. Align the holes in the lever and brake rod and insert the stock clevis pin (A).
3. Install the small saved flat washer (B) onto the clevis pin and insert the new cotter pin (4).
4. Place the large flat washer (C) removed earlier onto the brake lever mounting screw (D). Apply Loctite® 243 (blue) (Harley-Davidson Part Number 99642-97) to the threads of the screw, and reinstall into the brake lever mounting shaft. Tighten the screw to 12-16 ft-lbs (16.3-21.7 Nm).
5. Install the brake pedal pad (E) to the brake lever.

WARNING

After repairing the brake system, test brakes at low speed. If brakes are not operating properly, testing at high speeds can cause loss of control, which could result in death or serious injury. (00289a)

6. Check the brake lever for proper operation and clearance through its full travel.

NOTE

*A brake pedal pad **MUST** be in place to complete this installation. See a Harley-Davidson dealer for brake pad purchase.*

SERVICE PARTS

is03727

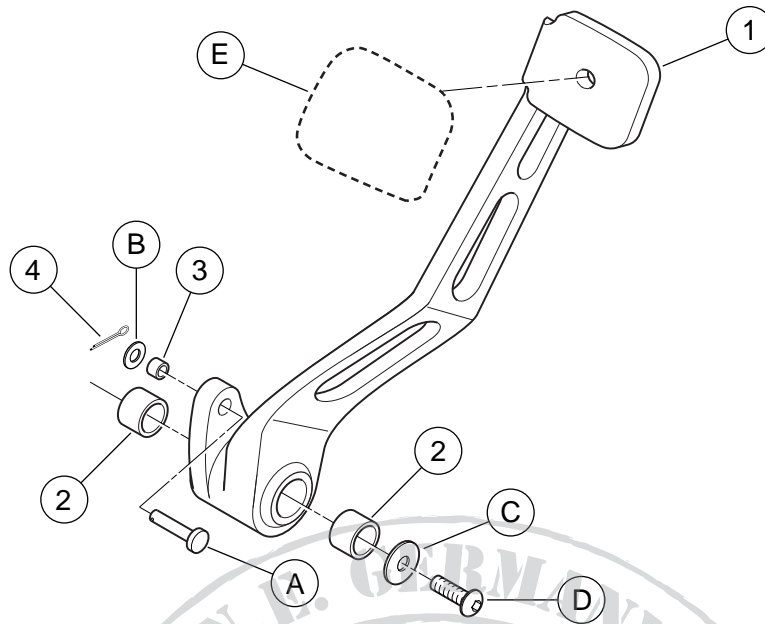

Figure 1. Service Parts: Billet Style Rear Brake Lever

Table 1. Service Parts Table

Item	Description (Quantity)	Part Number
1	Rear brake lever, including bushings	Not Sold Separately
2	• Bushing (0.625 inch ID x 0.75 inch) (2)	42642-00
3	• Bushing (0.250 inch ID x 0.177 inch)	42644-00
4	Cotter pin, 1/16 inch x 3/4 inch	515
Items mentioned in text, but not included in kit:		
A	Clevis pin	
B	Flat washer (small)	
C	Flat washer (large)	
D	Screw	
E	Brake pedal pad	