



INSTRUCTIONS

-J03636

REV. 12-20-2004

Kit Number 38753-04A

HYDRAULIC CLUTCH SIDE COVER AND RELEASE PUSHROD KIT

General

This kit is designed to be installed along with a Hydraulic Clutch Kit on 1999 and later Dyna models, 1999 and later FL Touring models, and 2000 and later Softail® model motorcycles with Twin Cam 88® engines that are **equipped with a Screamin' Eagle® 6-Speed Transmission or Screamin' Eagle 6-Speed Gear Set.**

If installing this kit on a vehicle that has previously been equipped with a 6-Speed Transmission or Gear Set, a Screamin' Eagle 6-Speed Side Cover Gasket (H-D Part Number 35148-03) will also be needed. This gasket is available separately from any Harley-Davidson dealer.

Harley-Davidson recommends that the clutch inspection cover gasket, Part Number 25416-99C (sold separately), be replaced when installing this kit. This gasket is available separately from any Harley-Davidson dealer.

See the instructions included with the Hydraulic Clutch Kit for a list of required additional parts.

⚠ WARNING

The rider's safety depends upon the correct installation of this kit. Use the appropriate Service Manual procedures. If the procedure is not within your capabilities or you do not have the correct tools, have a Harley-Davidson dealer perform the installation. Improper installation of this kit could result in death or serious injury. (00333a)

NOTE

This instruction sheet references Service Manual information. A Service Manual for your model motorcycle is required for this installation and is available from any Harley-Davidson Dealer.

Removing the Existing Components

⚠ WARNING

Perform this installation when the engine is cool. Working on or near the exhaust system when the engine is hot could result in severe burns. (00311a)

⚠ WARNING

To prevent accidental vehicle start-up, which could cause death or serious injury, disconnect battery cables (negative (-) cable first) before proceeding. (00307a)

⚠ WARNING

Disconnect negative (-) battery cable first. If positive (+) cable should contact ground with negative (-) cable connected, the resulting sparks can cause a battery explosion, which could result in death or serious injury. (00049a)

1. Refer to the SEAT and BATTERY sections of the Service Manual. Remove the seat and disconnect the battery cables, negative cable first.

2. If vehicle IS NOT currently equipped with a hydraulic clutch:

- a. Follow the instructions included with the Hydraulic Clutch Kit.
- b. Proceed to "Installing the Clutch-Release Plate".

If vehicle IS currently equipped with a hydraulic clutch:

NOTE

Standing the motorcycle upright is required so fluid doesn't spill. Ensure that the vehicle is supported securely.

- a. If necessary, remove the **left-side** passenger footpeg or footboard. Using a T27 TORX® drive head, remove the clutch-inspection (derby) cover from the primary chaincase.
- b. See Figure 1. Remove the clutch release plate retaining ring (5) and discard. Remove the release plate (2), adjuster rod and nut as an assembly, and discard.
- c. Proceed to "Installing the Clutch-Release Plate".

Installing the Clutch-Release Plate

1. Refer to Figure 1. Obtain the **new** clutch release plate assembly (2) from the Hydraulic Clutch Kit.

NOTE

The pushrod for a **6-speed** transmission has an end-to-end length of 15.552 in (39.5 cm), and an indented "punch mark" on the bearing end. The **5-speed** pushrod is 15.213 in (38.6 cm) long and has no mark on the bearing end.

2. Discard the **shorter** new pushrod and small retaining ring supplied with the Hydraulic Clutch Kit. Assemble the clutch-release plate assembly to the **new** pushrod (1) from **this kit** as shown, with the bearing side first. Install a small retaining ring (3) from **this kit** onto the pushrod.

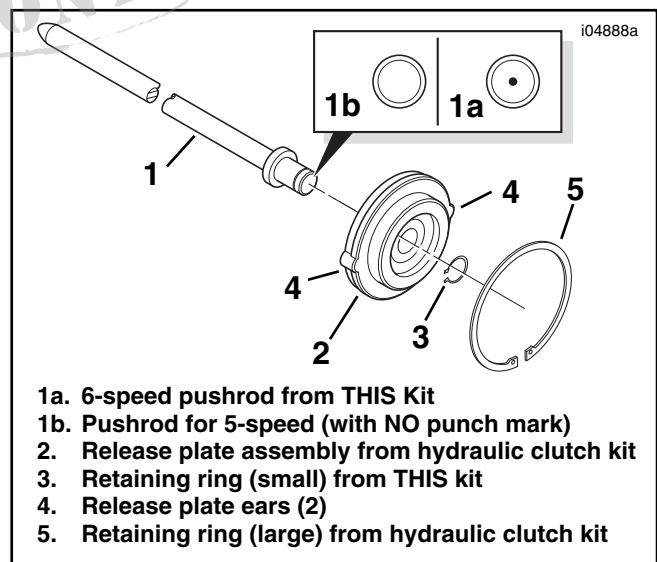

Figure 4. New Clutch Release Plate Assembly

3. Install the assembly into the clutch pressure plate. Fit the two ears (4) into the notches in the pressure-release plate. Push in until the clutch-release plate bottoms out against the shoulder in the pressure plate. Install the new large retaining ring (5) to the clutch-release plate, and verify that the ring is fully seated.

Installing the Clutch Master Cylinder

1. If vehicle IS NOT currently equipped with a hydraulic clutch:

- a. Follow the instructions included with the Hydraulic Clutch Kit.
- b. Proceed to "Installing the Transmission Side Cover".

If vehicle IS currently equipped with a hydraulic clutch: Proceed to "Installing the Transmission Side Cover".

Installing the Transmission Side Cover

1. Obtain the following items:
 - The **new** transmission side cover assembly from **this** kit.
 - A Screamin' Eagle 6-Speed Side Cover Gasket (H-D Part Number 35148-03), supplied with the **6-speed Transmission** or **Gear Set Kit** and also sold separately.

NOTE

The transmission side cover gasket from the **Hydraulic Clutch Kit** can be discarded.

- Two 2-1/4 inch (57 mm) long screws and four 1-1/2 in. (38 mm) long screws from the **6-speed Transmission** or **Gear Set Kit**.

NOTE

The six 2-1/4 inch (57 mm) long screws from the original cover assembly and the four 1-3/4 inch (44 mm) long screws from the **Hydraulic Clutch Kit** can be discarded.

2. Refer to Figure 2. Place the new cover gasket (4) over the hollow locating pins (5) on the transmission side door (bearing housing). Line up the new transmission side cover assembly (3, which includes the secondary actuator [slave] cylinder and bleeder screw) over the gasket.
3. Loosely install the two 2-1/4 in. (57 mm) long screws (1) into the top two holes in the new cover. Loosely install four 1-1/2 in. (38 mm) long screws (2) into the remaining four holes.
4. See Figure 3. Tighten the side cover screws, in the sequence shown, to 120-144 **in-lbs** (14-16 Nm).

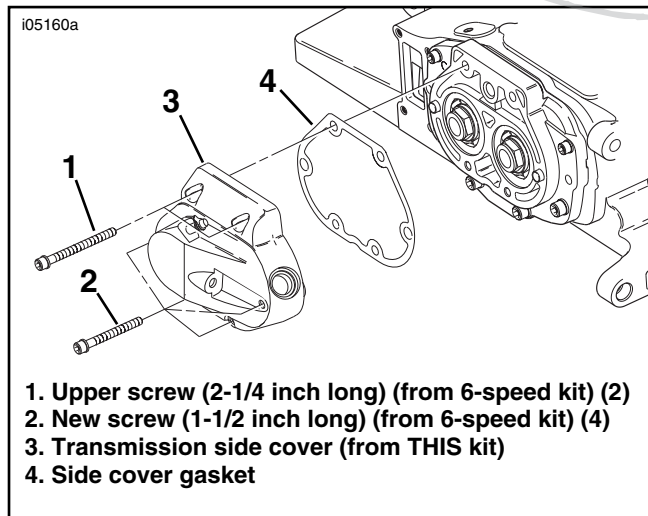

Figure 2. New Transmission Side Cover Installation

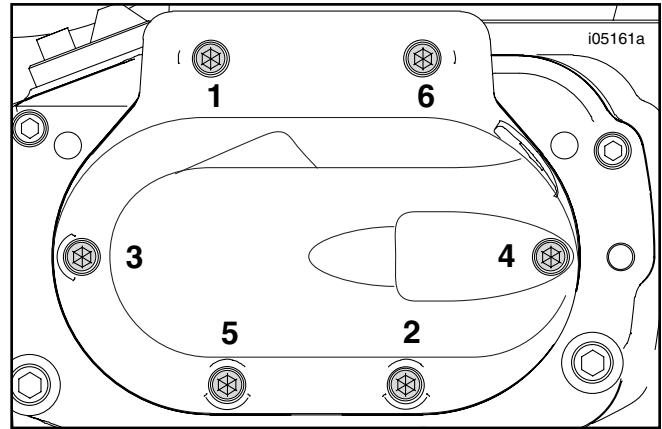

Figure 3. Torque Sequence, Transmission Side Cover

Installing the Clutch-Fluid Line

1. If vehicle IS NOT currently equipped with a hydraulic clutch:

- a. Follow the instructions included with the Hydraulic Clutch Kit.
- b. Proceed to "Bleeding the Clutch Fluid Line".

If vehicle IS currently equipped with a hydraulic clutch:

- a. Remove the cap plug from the transmission side cover if present. Install the fitting to the cover and tighten to 80-115 **in-lbs** (9-13 Nm).
- b. Proceed to "Bleeding the Clutch Fluid Line".

Bleeding the Clutch Fluid Line

1. Remove the bleeder cap from the transmission side cover bleeder valve. Install one end of a length of plastic tubing over the valve. Place the free end of the tube in a clean container.

NOTES

D.O.T. 4 or D.O.T. 5 Silicone Hydraulic Brake Fluid is used for the hydraulic clutch. It is referred to as clutch fluid in these instructions and in the Service Manuals.

Refer to the Owner's Manual to determine which type of brake fluid is appropriate for the motorcycle. Do not use other types of fluid, and do not mix brake fluids, as they are not compatible.

Do not overfill the master cylinder reservoir.

CAUTION

Direct contact of D.O.T. 5 brake fluid with eyes can cause eye irritation, swelling, and redness. Avoid eye contact. In case of eye contact flush with large amounts of water and get medical attention. Swallowing large amounts of D.O.T. 5 brake fluid can cause digestive discomfort. If swallowed, obtain medical attention. Use in well ventilated area. KEEP OUT OF REACH OF CHILDREN. (00144a)

WARNING

Direct contact of D.O.T. 4 brake fluid with eyes can cause irritation. Avoid eye contact. In case of eye contact flush with large amounts of water and get medical attention. Swallowing large amounts of D.O.T. 4 brake fluid can cause digestive discomfort. If swallowed, obtain medical attention. Use in well ventilated area. KEEP OUT OF REACH OF CHILDREN. (00240a)

CAUTION

D.O.T. 4 brake fluid will damage painted and molded-in color surfaces it comes in contact with. Always use caution and protect surfaces from spills whenever brake work is performed. Failure to comply can result in cosmetic damage. (00239a)

2. See Owner's Manual for hydraulic brake fluid requirements. Add appropriate hydraulic brake fluid to the master-cylinder reservoir until the fluid level is at or just below the fill line. Do not reuse old fluid. Use only fluid from a sealed container.
3. Activate the clutch lever 5-10 times.
4. Open the bleeder valve. Clutch fluid will flow from the bleeder valve through the tubing. It may take several minutes for fluid to exit the bleeder.
5. Once fluid exits the bleeder, close the bleeder valve.

NOTE
DO NOT OVERFILL.

6. If necessary, add additional clutch fluid to the master cylinder reservoir until the fluid level is at or just below the fill line.
7. Depress and hold the clutch hand-lever to build up hydraulic pressure.
8. Open the bleeder valve about one-half-turn. Clutch fluid will flow from the bleeder valve through the tubing. Close the bleeder valve when the clutch hand-lever has moved 50% to 75% of its full range of travel. Allow the clutch hand-lever to return slowly to its released position.
9. Repeat Steps 6 through 8 until all air bubbles are purged.
10. Tighten the bleeder valve to 80-100 **in-lbs** (9.0-11.3 Nm) and install the bleeder cap.
11. Again, if necessary, add clutch fluid to the master cylinder reservoir until the fluid level is at or just below the fill line.
12. Verify proper operation of the master-cylinder relief port. Actuate the clutch hand-lever. A slight spurt of fluid will break the fluid surface in the reservoir compartment if all internal components are working properly.

NOTE

The angular shape of the clutch master-cylinder cover makes one side thicker than the other.

13. Obtain the clutch master-cylinder cover kit (cover, gasket, sight glass and two Phillips screws), purchased separately. Install the cover (with gasket) on the master-cylinder reservoir so that the **thicker** side is over the clutch-line fitting.
14. Fasten the cover with the two Phillips screws. Tighten the screws to 6-8 **in-lbs** (0.7-0.9 Nm).

NOTE

The sight glass enables the rider to visually check clutch fluid level without removing the master-cylinder cover. When the reservoir is full, the sight glass is dark. As the fluid level drops, the glass lightens up to indicate this condition to the rider.

Measuring Clutch Plate Lift

1. Attach the standoff of a dial indicator to one of the 1/4-20 clutch-inspection (derby) cover mounting holes. Position the anvil to the end of the push rod.

WARNING

Insufficient clutch-release plate movement can lead to difficulty or inability to shift, causing loss of control, which could result in death or serious injury. (00345a)

2. Actuate the clutch lever to measure the axial movement of the push rod and the clutch-release plate assembly. The axial movement needs to be **at least** 0.065 in. (1.65 mm).

NOTE

*Proper bleeding of the system will typically yield plate movement of greater than .065 in. (1.65 mm). If clutch release plate movement is less than .065 in., the system **MUST BE RE-BLED**.*

Installing the Clutch-Inspection Cover

1. If so equipped, remove the quad-ring clutch-inspection cover seal from the groove in the primary chaincase cover.

NOTE

*If the quad-ring clutch-inspection cover seal **is not** being replaced with gasket 25416-99C as recommended,*

- *wipe all lubricant from the seal and inspect it for cuts, tears or signs of deterioration.*
- *Swab all lubricant from the quad-ring groove.*
- *Install the seal into the groove with the nubs contacting the groove walls.*

*If the quad-ring seal **is** damaged, replace with gasket 25416-99C.*

2. To avoid punching holes in the clutch inspection cover gasket or enlarging the existing holes, install the derby cover and gasket as follows:
 - a. Align the triangular shaped hole in the gasket with the top hole in the derby cover. Be sure the rubber molding and the words "towards clutch" face the motorcycle.
 - b. Obtain one of the screws (with captive washer) removed earlier. Insert the screw threads through the top hole in the derby cover, and carefully thread it all the way through the triangular shaped hole in the gasket. Do not push the screw through the hole.
 - c. Hang the derby cover on the primary chaincase cover flange by starting the top cover screw.
 - d. Start the remaining four screws with washers.

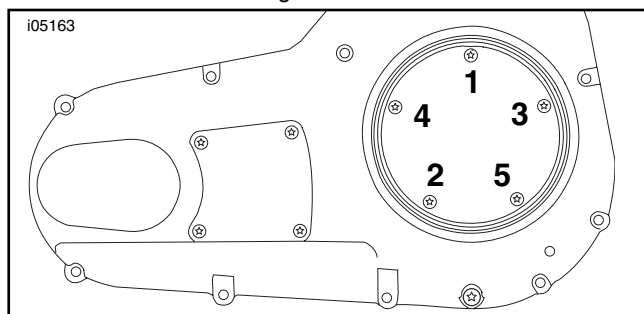

Figure 4. Torque Sequence, Primary Chaincase Cover

- Using a T27 TORX drive head, alternately tighten the screws to 84-108 **in-lbs** (10-12 Nm) in the sequence shown in Figure 4.

Final Assembly

- Check the "O"-ring on the transmission drain plug removed earlier for tears, cuts or general deterioration, and replace if necessary.
- Install the drain plug and torque to 14-21 ft-lbs (19-28 Nm).

CAUTION

Do not over-tighten filler or drain plug. Doing so could result in a lubricant leak. (00200b)

- Fill the transmission with the proper transmission lubricant. See the MAINTENANCE section of the applicable Service Manual.
- Check the "O"-ring on the filler plug/ dipstick removed from the old transmission side cover for tears, cuts or general deterioration, and replace if necessary. Install the filler plug/ dipstick into the new transmission side cover assembly.

CAUTION

Be sure exhaust pipes do not contact frame or components. Contact will transmit vibration to the rider. (00348a)

- See EXHAUST SYSTEM INSTALLATION in the Service Manual. Re-install and tighten all exhaust-system components loosened or removed at the beginning of the installation. Any gaskets or clamps that were

removed should be replaced with **new** parts.

- For 2004 and later FXSTS/I models:** Replace the left-side turn signal mounting bracket with a **new** bracket (Part Number 67355-04, purchased separately).

For models with handlebar-mounted turn signals: Install the left-side turn signal removed earlier.

For ALL models: Install the left-side rear-view mirror. Adjust for proper field of vision and tighten the acorn nut to 12 ft-lbs (16 Nm). Check mirror adjustment and reposition if necessary.

WARNING

Connect positive (+) battery cable first. If positive (+) cable should contact ground with negative (-) cable connected, the resulting sparks can cause a battery explosion, which could result in death or serious injury. (00068a)

- Refer to the Service Manual, and follow instructions to connect the battery cables, positive cable first.
- Follow the instructions in the Service Manual to install the seat.

WARNING

After installing seat, pull upward on seat to be sure it is locked in position. While riding, a loose seat can shift causing loss of control, which could result in death or serious injury. (00070b)

- If necessary, install the right-side saddlebag.
- Test ride the motorcycle. If the clutch does not work properly, it may be necessary to re-bleed the clutch fluid line and re-measure the clutch-plate lift.



Service Parts

Part Number 38753-04A

Date 12/04

Hydraulic Clutch Side Cover & Release Kit

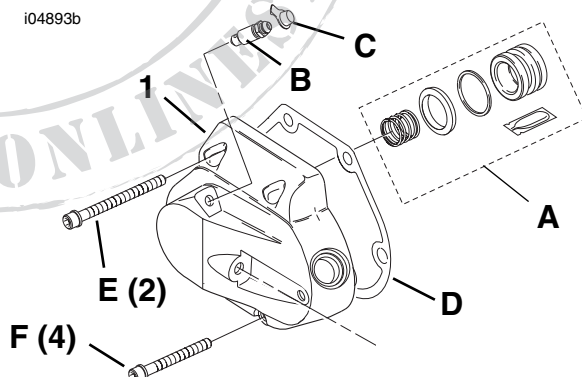
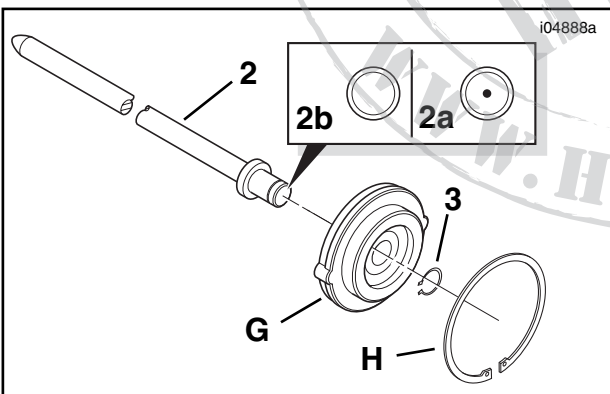

Item	Description (Quantity)	Part Number
1	Transmission side cover	38754-04A
2	Pushrod, clutch release (6-speed) (*with marked end, see inset 2a)	38755-04
3	Retaining ring, external, 3/8 in.	11143

*Note:

Plain end (see 2b) indicates shorter 5-speed pushrod, which will not fit with 6-speed transmission.

Also available:

A	Secondary Actuator Cylinder Service Kit 36822-04
B	Bleeder screw 44613-02
C	Bleeder screw cap 43817-02

Items not included in kit:

D	6-speed side cover gasket 35148-03
E	2-1/4 in. (57 mm) long screw 4717A (2) from 6-Speed Transmission or Gear Set Kit
F	1-1/2 in. (38 mm) long screw 4718A (4) from 6-Speed Transmission or Gear Set Kit
G	Release plate assembly 36731-91 from Hydraulic Clutch Kit
H	Large retaining ring 37909-90 from Hydraulic Clutch Kit