



INSTRUCTIONS

-J05819

2015-03-27

CLUTCH MASTER CYLINDER COVER KIT

GENERAL

Kit Number

39700094A, 36700119

Models

For model fitment information, see the P&A Retail Catalog or the Parts and Accessories section of www.harley-davidson.com (English only).

Kit Contents

See Figure 1 and Table 1.

INSTALLATION

⚠ CAUTION

Direct contact of D.O.T. 4 brake fluid with eyes can cause irritation. Avoid eye contact. In case of eye contact flush with large amounts of water and get medical attention. Swallowing large amounts of D.O.T. 4 brake fluid can cause digestive discomfort. If swallowed, obtain medical attention. Use in well ventilated area. **KEEP OUT OF REACH OF CHILDREN. (00240a)**

NOTICE

D.O.T. 4 brake fluid will damage painted and body panel surfaces it comes in contact with. Always use caution and protect surfaces from spills whenever brake work is performed. Failure to comply can result in cosmetic damage. (00239b)

NOTICE

D.O.T. 4 hydraulic brake fluid is used in the hydraulic clutch. Do not use other types of fluids as they are not compatible and could cause equipment damage. (00353a)

NOTE

If DOT 4 brake fluid contacts painted surfaces, IMMEDIATELY flush area with clear water.

1. Position motorcycle on a flat, level surface. Turn handlebar so master cylinder is level.
2. Cover nearby surfaces with a polyethylene protective sheet to help protect against damage to finish caused by spillage of DOT 4 brake fluid.

NOTE

Do not overfill clutch reservoir. Clutch fluid volume increases with clutch wear. Overfilling can lead to damaged seals and damage to clutch system.

3. Clean the clutch master cylinder cover and the surrounding area. Remove and discard the original cover, gasket and screws.

NOTICE

Do not allow dirt or debris to enter the master cylinder reservoir. Dirt or debris in the reservoir can cause improper operation and equipment damage. (00205c)

4. Fill reservoir with DOT 4 brake fluid. Do not reuse old brake fluid. Use only DOT 4 fluid from a sealed container.

⚠ WARNING

Be sure the master cylinder relief port is not plugged. A plugged relief port can cause brake drag or lockup and loss of vehicle control, which could result in death or serious injury. (00317a)

NOTE

Before installing the master cylinder cover, verify that the cover gasket bellows is not expanded. If bellows is expanded, brake fluid ejects from the reservoir during cover installation, which could damage the vehicle finish.

5. Verify proper operation of the master cylinder relief port by actuating the brake pedal or lever. A slight spurt of fluid will break the fluid surface in the reservoir if internal components are working properly.
6. See Figure 1. Note the shape of the master cylinder cover. One end is thinner than the other. With the thinner end positioned above the brake line fitting, install the cover (with gasket compressed) Fasten the cover and gasket to the reservoir with two screws (4). Tighten the screws to 1.4–1.7 N·m (12–15 in-lbs).



SERVICE PARTS

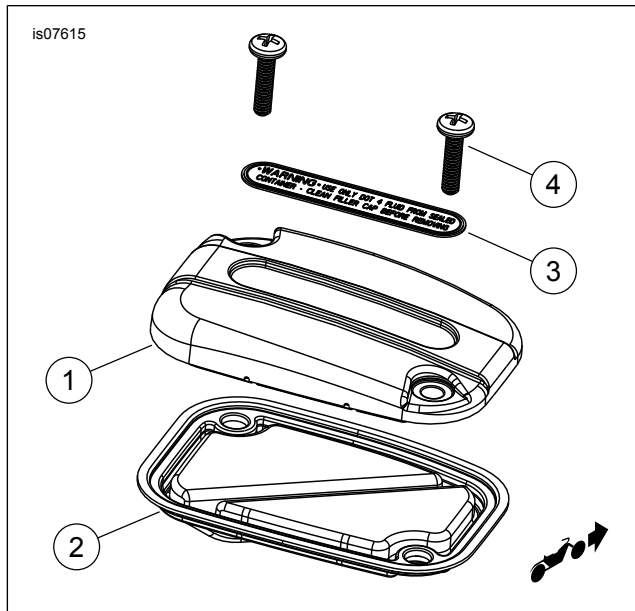

Figure 1. Service Parts: Clutch Master Cylinder Cover Kit

Table 1. Service Parts

Item	Description (Quantity)	Part Number
1	Cover, clutch master cylinder	Not sold separately
2	Gasket, master cylinder cover	Not sold separately
3	Decal, DOT 4 brake fluid (chrome)	Not sold separately
4	Screw, master cylinder cover, bright finish (2) (Kit 36700094A)	3089
	Screw, master cylinder cover, black (2) (Kit 36700119)	2590