



INSTRUCTIONS

-J04278

REV. 2010-12-01

CUSTOM HAND LEVER KITS

GENERAL

Kit Numbers

38843-08, 38845-08, 38853-08, 36700004

Models

For model fitment information, see the P&A Retail Catalog or the Parts and Accessories section of www.harley-davidson.com (English only).

These kits will not fit police models, or models equipped with a hydraulic clutch.

Additional Parts Required

Two **new** copper brake line gaskets (part number 41751-06A) will be required for proper installation of this kit.

Tools and Supplies Required

Fresh, uncontaminated D.O.T. 4 brake fluid from a sealed container will be needed. GM-40M grease (2 gram bag, part number 42820-04) will also be needed. These items are available from a Harley-Davidson Dealer.

⚠ WARNING

The rider's safety depends upon the correct installation of this kit. Use the appropriate service manual procedures. If the procedure is not within your capabilities or you do not have the correct tools, have a Harley-Davidson dealer perform the installation. Improper installation of this kit could result in death or serious injury. (00333a)

NOTE

This instruction sheet references Service Manual information. A Service Manual for your model motorcycle is required for this installation and is available from a Harley-Davidson Dealer.

⚠ WARNING

Brakes are a critical safety component. Contact a Harley-Davidson dealer for brake repair or replacement. Improperly serviced brakes can adversely affect brake performance, which could result in death or serious injury. (00054a)

Kit Contents

See Figure 3 and Table 1.

BRAKE LEVER INSTALLATION

Rest the motorcycle on the jiffy stand, with the front wheel turned toward the right fork stop so that the master cylinder is in a level position.

Front Brake Master Cylinder and Lever Removal

⚠ CAUTION

Direct contact of D.O.T. 4 brake fluid with eyes can cause irritation. Avoid eye contact. In case of eye contact flush with large amounts of water and get medical attention. Swallowing large amounts of D.O.T. 4 brake fluid can cause digestive discomfort. If swallowed, obtain medical attention. Use in well ventilated area. KEEP OUT OF REACH OF CHILDREN. (00240a)

NOTICE

D.O.T. 4 brake fluid will damage painted and body panel surfaces it comes in contact with. Always use caution and protect surfaces from spills whenever brake work is performed. Failure to comply can result in cosmetic damage. (00239b)

NOTE

Immediately wipe up any brake fluid spillage with a clean, dry, soft cloth. Follow up by thoroughly wiping affected area with a clean, damp, soft cloth (small spills) or washing with a large quantity of soapy water (large spills).

Cover nearby motorcycle surfaces with a polyethylene protective sheeting to help protect against damage to finish caused by spillage or splash of D.O.T. 4 brake fluid.

1. Drain the front brake master cylinder.
 - a. Open the bleeder nipple caps on each of the front brake calipers.
 - b. Install one end of a length of clear plastic tubing over each caliper bleeder valve, while placing the free ends in a suitable container.
 - c. Open the bleeder valves about one-half turn. Pump the brake hand lever to drain the brake fluid from the reservoir.
 - d. Close the bleeder valves. Loosely install the master cylinder cover with the cover screws.
2. **FLHRS/FLHRSE models:** Remove the mirror and front turn signal from the brake hand lever bracket.
All other models: Remove the mirror from the brake hand lever bracket.
 - a. Remove the acorn nut, lock washer and (if equipped) turn signal lamp bracket from the mirror stem. Secure the turn signal lamp to the handlebar.
 - b. Remove the threaded stem of the mirror from the brake lever bracket and set aside for reassembly.

- Clean the area surrounding the banjo bolt at the front brake master cylinder. Remove the banjo bolt and the two copper gaskets to disconnect the hydraulic brake line fitting from the master cylinder. Discard the washers but save the banjo bolt.

NOTICE

Do not remove or install the master cylinder assembly without first positioning a 5/32-inch (4 mm) thick insert between the brake lever and lever bracket. Removing or installing the master cylinder assembly without the insert in place may result in damage to the rubber boot and plunger on the front stoplight switch. (00324a)

NOTE

A section of corrugated cardboard or the eyelet of an ordinary cable strap can be used as the 4 mm (5/32 inch) spacer. See Figure 1.

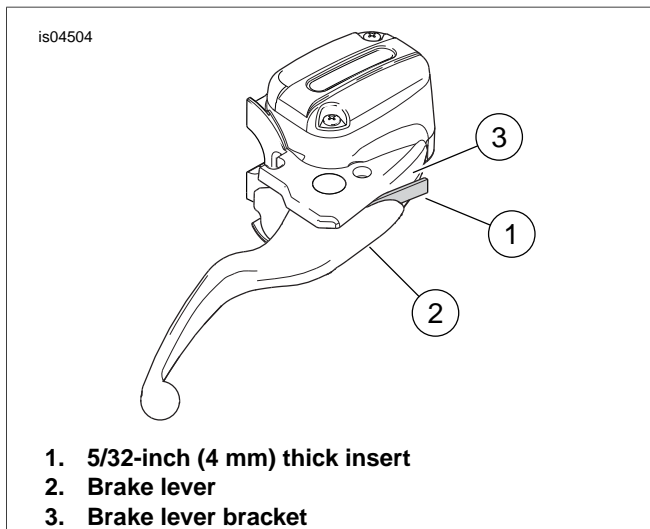

Figure 1. Protect Stop Light Switch

- Insert a 4 mm (5/32 inch) thick spacer between the brake lever and the lever bracket.
- Using a T27 TORX® drive head, remove and discard the two screws and flat washers securing the handlebar clamp to the master cylinder housing. Remove the brake lever/master cylinder assembly and clamp from the handlebar.

WARNING

Wear safety glasses or goggles when removing or installing retaining rings. Retaining rings can slip from the pliers and could be propelled with enough force to cause serious eye injury. (00312a)

- See Figure 3 and the FRONT BRAKE MASTER CYLINDER section of the Service Manual. Remove the retaining ring (7) from the groove in the pivot pin (6).
- Remove the pivot pin from the brake lever and master cylinder housing (A). Discard the original equipment (O.E.) brake lever (3), pivot bushing (4), pivot pin (6) and snap ring (7).

New Front Brake Lever Installation

- Verify that the pivot bushing (4) is installed in the **new** brake lever (3) from the kit.

Apply a small amount of GM-40M grease (part number 42820-04) to the area where the master cylinder pushrod seats against the brake lever. **DO NOT** apply grease to the stop-light switch contact surface of the lever.

Align the hole in the brake hand lever with the hole in the master cylinder bracket. From the top of the assembly, slide the **new** pivot pin (6) down through the bracket and hand lever.

Check that the pushrod is properly seated on the lever.

WARNING

Wear safety glasses or goggles when removing or installing retaining rings. Retaining rings can slip from the pliers and could be propelled with enough force to cause serious eye injury. (00312a)

- Install the **new** retaining ring (7) in the pivot pin groove. Verify that the retaining ring is completely seated in the groove.

NOTICE

Do not remove or install the master cylinder assembly without first positioning a 5/32-inch (4 mm) thick insert between the brake lever and lever bracket. Removing or installing the master cylinder assembly without the insert in place may result in damage to the rubber boot and plunger on the front stoplight switch. (00324a)

NOTE

A section of corrugated cardboard or the eyelet of an ordinary cable strap can be used as the 4 mm (5/32 inch) spacer. See Figure 1.

- Place a 4 mm (5/32 inch) thick insert between the brake lever and the lever bracket.
- See Figure 2. Position the brake lever/master cylinder assembly inboard of the switch housing (4) assembly, engaging the tab (1) on the lower switch housing in the groove (3) at the top of the brake lever bracket (2).
- Obtain the clamp screws and flat washers removed earlier. Place a washer onto the threads of each screw. Align the holes in the handlebar clamp with those in the master cylinder housing, and use a T27 TORX drive head to start the two screws into the threaded holes.
- Adjust the position of the brake lever assembly on the handlebar for rider comfort and posture. Beginning with the top screw, tighten the screws to 70-80 in-lbs (7.9- 9.0 Nm).

NOTICE

Avoid leakage. Be sure gaskets, banjo bolt(s) and brake line are clean and undamaged before assembly. (00323a)

- Position **new** copper gaskets (purchased separately) on each side of the brake line fitting. Insert the banjo bolt through the gaskets and fitting. Thread the bolt into the master cylinder housing and tighten to 13-15 ft-lbs (17-20 Nm).

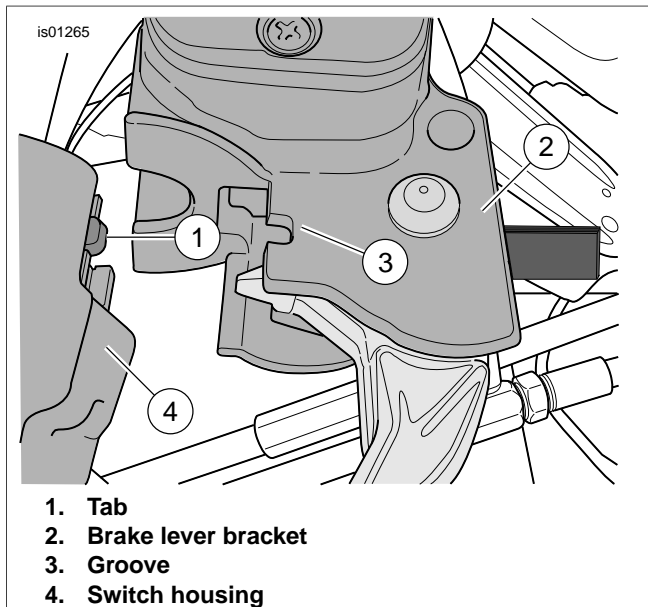

Figure 2. Brake Lever Bracket to Switch Housing

NOTES

For ABS-equipped vehicles: Refer to the Service Manual for brake bleeding procedures.

For Non-ABS vehicles: Refer to Steps 15 through 25 that follow.

15. If removed earlier, install one end of a length of clear plastic tubing over the **right side** caliper bleeder valve, and place the free end in a suitable container.
Verify that **both** caliper bleeder valves are closed tightly.
16. Remove the master cylinder cover. Rest the motorcycle on the jiffy stand, with the front wheel turned toward the right fork stop so that the master cylinder is in a level position.

CAUTION

Direct contact of D.O.T. 4 brake fluid with eyes can cause irritation. Avoid eye contact. In case of eye contact flush with large amounts of water and get medical attention. Swallowing large amounts of D.O.T. 4 brake fluid can cause digestive discomfort. If swallowed, obtain medical attention. Use in well ventilated area. KEEP OUT OF REACH OF CHILDREN. (00240a)

NOTES

The brake system on this vehicle uses D.O.T. 4 BRAKE FLUID. Do not mix grades of brake fluid as they are not compatible. Mixing different types of fluid may adversely affect braking ability and lead to brake failure which could result in death or serious injury.

Immediately wipe up any brake fluid spillage with a clean, dry, soft cloth. Follow up by thoroughly wiping affected area with a clean, damp, soft cloth (small spills) or washing with a large quantity of soapy water (large spills).

Verify that the fuel tank, front fender, chrome and footboards are covered with protective sheeting.

17. Add D.O.T. 4 HYDRAULIC BRAKE FLUID to the master cylinder reservoir until the fluid level reaches the MAX

marking inside the reservoir. Do not reuse old brake fluid. Use only D.O.T. 4 fluid from a sealed container.

WARNING

Be sure the master cylinder relief port is not plugged. A plugged relief port can cause brake drag or lockup and loss of vehicle control, which could result in death or serious injury. (00317a)

18. Verify proper operation of the master cylinder relief port. Actuate the brake hand lever. A slight spurt of fluid will break the fluid surface in the reservoir compartment if all internal components are working properly.
19. Pump the front brake hand lever to build up hydraulic pressure.
20. **While holding the lever**, open the **right side** caliper bleeder valve about one-half turn. Brake fluid will flow from the bleeder valve through the tubing.
Close the bleeder valve as soon as a loss of pressure is detected. Allow the brake hand lever to return slowly to its released position.

NOTE

Pay careful attention to the fluid level in the master cylinder reservoir during the bleeding procedure. To avoid drawing air into the brake lines, always add fluid as needed to the reservoir before it becomes completely empty.

21. Repeat Steps 12 and 13 until all air bubbles are purged and a solid column of fluid is observed in the bleeder tube.
22. Final tighten the right side bleeder valve to 80-100 **in-lbs** (9.0-11.3 Nm), and install the bleeder cap.
23. If removed earlier, install one end of a length of clear plastic tubing over the **left side** caliper bleeder valve and place the free end in a suitable container.
Add brake fluid to the master cylinder reservoir until the fluid level reaches the MAX marking inside the reservoir. Repeat Steps 5 through 8 for the left side brake line.
24. Add brake fluid as needed to the master cylinder reservoir per the instructions in the Service Manual.

NOTE

Before installing the master cylinder cover, verify that the cover gasket bellows is not expanded. If bellows is expanded, brake fluid will be ejected from the reservoir during cover installation, which could damage the vehicle finish.

25. Note that the shape of the master cylinder cover makes one end thinner than the other. Install the cover (with gasket compressed) on the master cylinder reservoir so that the thinner end is positioned above the brake line fitting.
Install two Phillips-head screws to fasten the cover to the reservoir. Tighten the screws to 7-11 **in-lbs** (0.8-1.2 Nm).

NOTE

The sight glass enables the rider to visually check the brake fluid level without removing the master cylinder cover. When the master cylinder is level and the reservoir is full, the sight glass is dark. As the fluid level drops, a bubble of air will start to appear in the glass to indicate this condition to the rider.

26. Check the front brake for proper operation. There should be no free play in the hand lever. A slight preload is normal.

Check that the stop light illuminates when the brake lever is actuated.

⚠ WARNING

Be sure that all lights and switches operate properly before operating motorcycle. Low visibility of rider can result in death or serious injury. (00316a)

CLUTCH LEVER INSTALLATION

See the CLUTCH CONTROL section of the Service Manual for clutch lever (8) removal, installation and adjustment procedures.



SERVICE PARTS

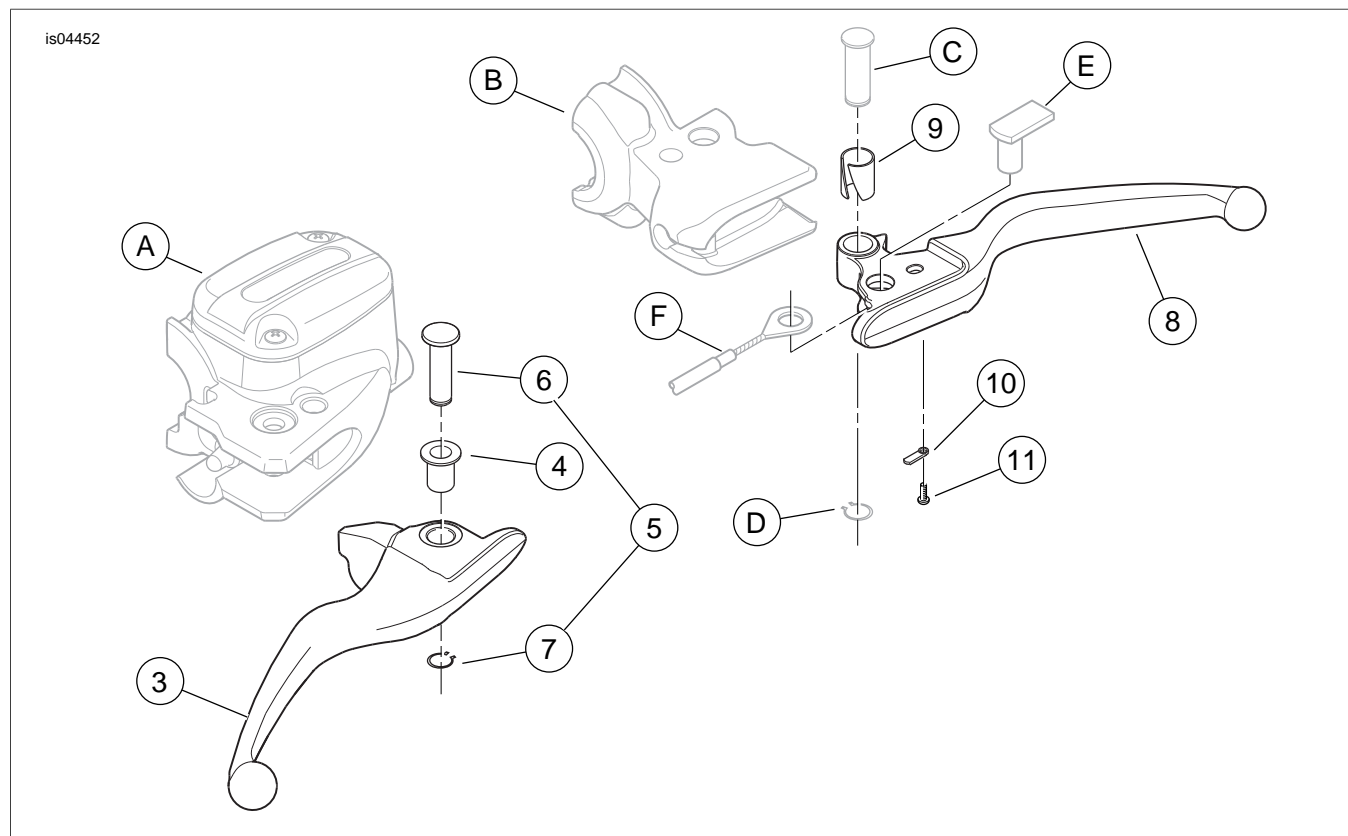

Figure 3. Service Parts: Hand Control Lever Kits

Table 1. Service Parts: Hand Control Lever Kits

Kit	Item	Description (Quantity)	Part Number
Kit 38843-08 Chrome Levers	1	Brake hand lever, chrome (includes Items 3 through 7)	42271-06A
	2	Clutch hand lever, chrome (includes Items 8 through 11)	38844-08
Kit 38845-08 Black Levers	1	Brake hand lever, black (includes Items 3 through 7)	Not sold separately
	2	Clutch hand lever, black (includes Items 8 through 11)	Not sold separately
Kit 38853-08 Slotted Levers	1	Brake hand lever, slotted (includes Items 3 through 7)	42916-06
	2	Clutch hand lever, slotted (includes Items 8 through 11)	38855-08
Kit 36700004 Edge Cut Levers	1	Brake hand lever, slotted (includes Items 3 through 7)	Not sold separately
	2	Clutch hand lever, slotted (includes Items 8 through 11)	Not sold separately
Parts common to ALL Kits	3	Brake hand lever (includes Item 4)	Not sold separately
	4	• Bushing, brake lever pivot	Not sold separately
	5	Pivot pin kit (polished). For all Kits EXCEPT 38845-08 (includes Items 6 and 7) Pivot pin kit (black). For Kit 38845-08 (includes Items 6 and 7)	42105-06A 42860-06B
	6	• Pivot pin, brake lever	Not sold separately
	7	• Retaining ring	11615
	8	Clutch hand lever	Not sold separately
	9	Bushing, clutch lever pivot	45423-92
	10	Clip, anti-rattle	45021-86
	11	Screw	90770-79

Reference items not included in kit:

Table 1. Service Parts: Hand Control Lever Kits

Kit	Item	Description (Quantity)	Part Number
	A	Front brake master cylinder	
	B	Clutch hand lever bracket	
	C	Original equipment (O.E.) clutch lever pivot pin	
	D	O.E. clutch lever retaining ring	
	E	O.E. clutch cable anchor pin	
	F	O.E. clutch control cable	

