



INSTRUCTIONS

-J04071

REV. 2006-11-21

IRONSIDE SHIFTER PEG

GENERAL

Kit Numbers

34720-07

Models

For model fitment information, please see the P&A Retail Catalog or the Parts and Accessories section of www.harley-davidson.com (English only).

Kit Contents

See Figure 1 and Table 1.

INSTALLATION

1. Remove and discard the original equipment shifter peg. If needed, use a heat gun to apply heat to the shift lever and shifter peg threads to aid in peg removal.
2. See Figure 1. Insert the screw (4) through the peg (1), tread (2), spacer (3), and lockwasher (5) into the shift lever. Tighten the screw to 11-15 ft-lbs (15-20 Nm).

SERVICE PARTS

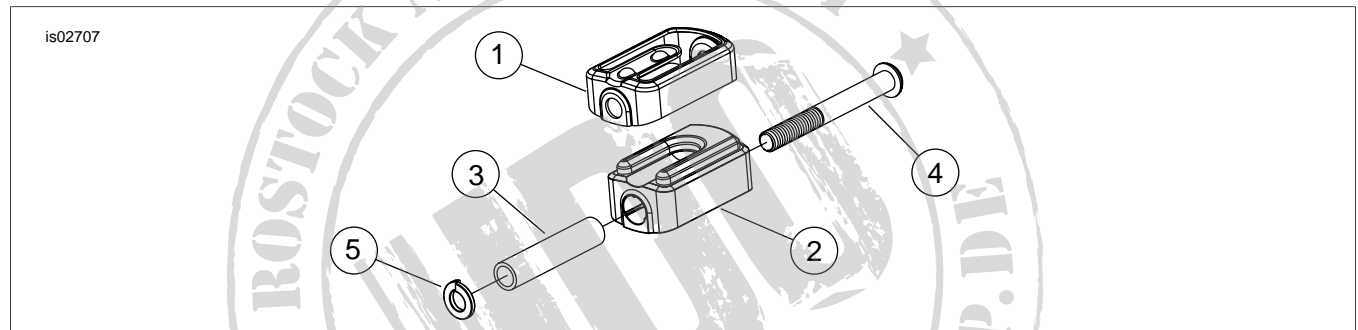

Figure 1. Service Parts: Ironside Shifter Peg Kit

Table 1. Service Parts Table

Item	Description (Quantity)	Part Number
1	Casting, shifter peg	49292-07
2	Tread, shifter peg	49295-07
3	Spacer tube	33940-03
4	Screw, 5/16-24 x2-5/8 inch w/lock patch, chrome plated	94545-03
5	Lockwasher, 5/16 inch, chrome plated	94081-90T