



INSTRUCTIONS

-J04381

2007-05-15

CUSTOM SHIFTER PEG KIT

GENERAL

Kit Number

34635-90T

Models

For model fitment information, please see the P&A Retail Catalog or the Parts and Accessories section of www.harley-davidson.com (English only).

NOTE

A Service Manual for your model motorcycle is available from a Harley-Davidson Dealer.

Kit Contents

See Figure 1 and Table 1.

INSTALLATION

1. Remove previously installed shifter peg from motorcycle. Discard peg and screw.
2. See Figure 1. Insert body (2) into cushion (3). Install to shift pedal (A) with screw (1).
3. Rotate to orient the Harley-Davidson logo into desired position.
4. Tighten screw to 15–20 N·m (11–15 ft·lbs).

SERVICE PARTS

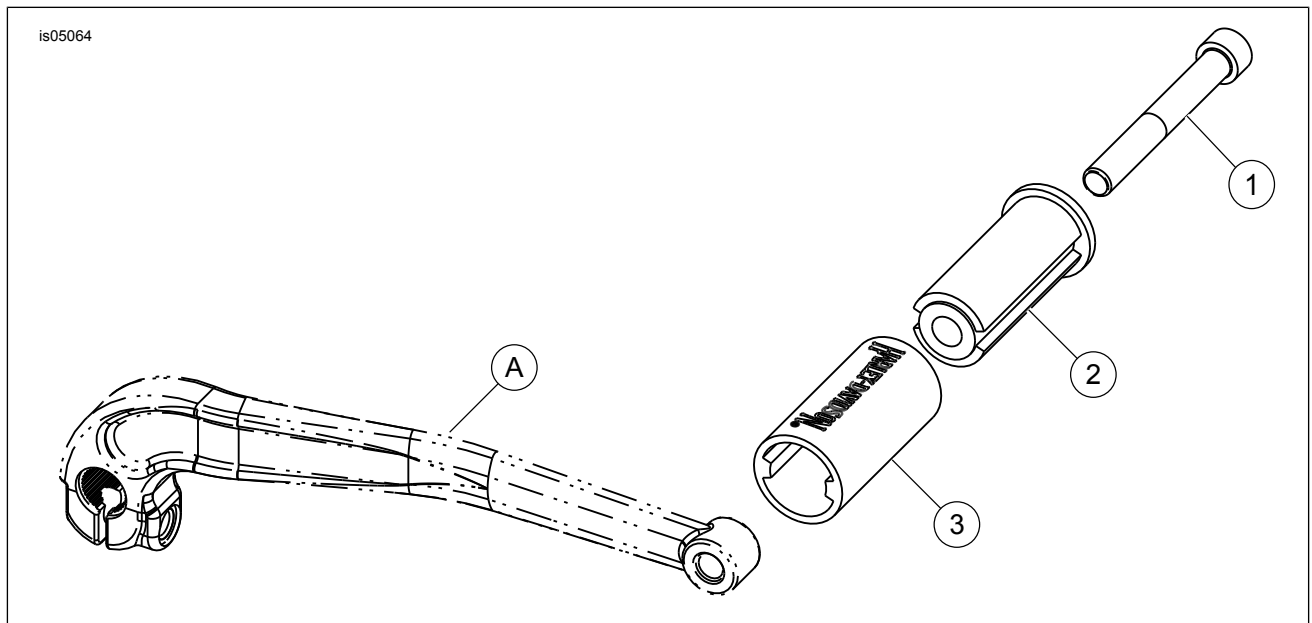

Figure 1. Service Parts: Shifter Peg Kit

Table 1. Service Parts Table

Item	Description (Quantity)	Part Number
1	Screw	Not Sold Separately
2	Body	Not Sold Separately
3	Cushion	Not Sold Separately
Items mentioned in text, but not included in kit:		
A	Shift pedal	

