



# INSTRUCTIONS

-J01261

REV. 9-10-01

Kit Numbers 33891-98 and 33892-98

## SPORTSTER FORWARD FOOT CONTROLS

### General

This kit is designed for installation on 1991-2003 XL Sportster® models and includes all parts required to make a complete conversion from the standard controls to forward controls.

See Service Parts illustration for kit contents.

#### NOTE

A Service Manual for your motorcycle is available from your Harley-Davidson Dealer.

#### WARNING

A Service Manual is needed to install this kit. The rider's safety depends upon the correct installation of this kit. If the procedure is not within your capabilities or you do not have the correct tools, have your Harley-Davidson dealer perform the installation. Improper installation of this kit could result in death or serious injury.

### Installation (all callouts refer to Service Parts illustration unless noted otherwise)

#### LEFT (SHIFTER) SIDE

1. Remove stock footrest assembly and save footrest for reinstallation. Replace existing sockethead capscrews that attached footrest bracket to primary cover with washers (5) and shorter screws (21) from kit.

2. Remove stock shift lever and save shifter peg and mounting screw.
3. See Figure 1. Remove left side stock motor mount and save nuts, washers, and P-clamp for clutch cable. The bolts will be replaced.
4. Put Loctite 243 on threads of left side foot control support (15) and thread support into left side machine motor mount (11). Install C-clip (8) onto support where it exits the backside of machine motor mount to hold support in place.
5. Install left side motor mount assembly in place of stock motor mount using washers and nuts saved from step 3, and bolts (22 and 23) from kit. Tighten bolts to 25-30 ft-lbs (41-47 Nm). Make sure to reinstall the P-clamp and clutch cable in the same hole location they were removed from in step 3.
6. Install shift lever (14) from kit using stock fastener.
7. Put Loctite 243 on threads of clevis mounting screw (4) and install shift lever pedal (13), clevis (17), and footrest (stock), as shown. To install footrest, place a spring washer (19), along with the mount end of the footpeg, inside the slots of the clevis. Make sure the spring washer is positioned inside the clevis with the square edge towards the inside as shown in Figure 3. Secure footpeg and spring washer with bolt (2) and locknut (7). Tighten locknuts to 19 ft-lbs (26 Nm).

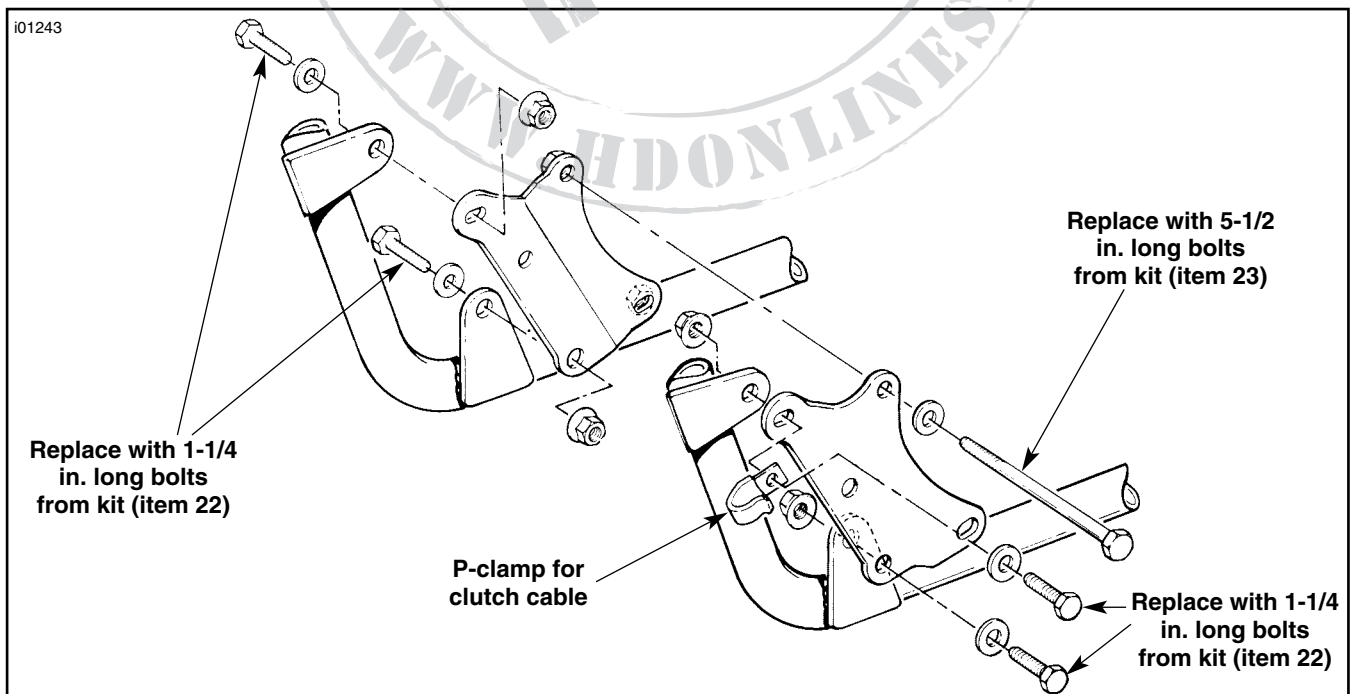
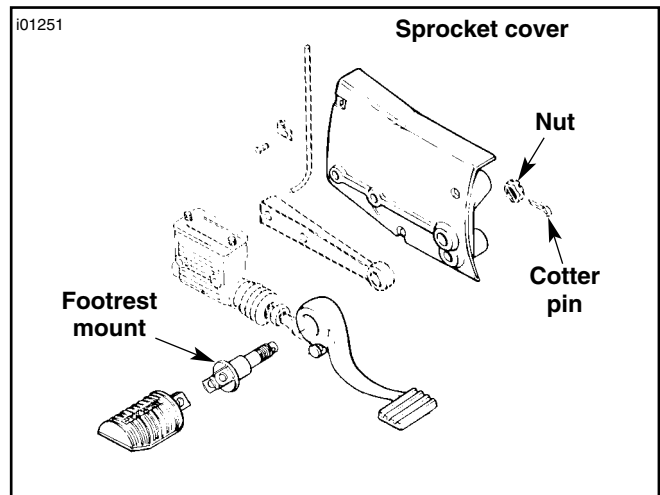

Figure 1. Stock Front Motor Mounts

- Assemble tie rod ends (12) and jam nuts (6) to shift rod (9) and connect assembly to shift lever pedal and shift lever with washers (5) and bolts (1). Make sure that the bends in the shift rod are positioned properly as shown in Figure 4.

### **RIGHT (BRAKE) SIDE**

- Remove exhaust system according to Service Manual instructions.
- Remove clip that holds brake line on sprocket cover.
- Remove the two sockethead screws that hold the rear brake master cylinder in place. Loosen rear brake jam nut at master cylinder. Turn push rod at flats until rod end is free.
- Remove the three screws that hold the sprocket cover in place.
- See Figure 2. Remove the cotter pin and nut that holds the footrest mount in place. Replace the footrest mount with sockethead capscrew (3) from kit and reinstall the nut removed from the footpeg. Save footrest for reinstallation.
- Reinstall sprocket cover and brake line clip.
- See Figure 1. Remove right side stock motor mount and save nuts and washers. The bolts will be replaced.
- Put Loctite 243 on threads of right side foot control support (16) and thread support into right side machine motor mount (10). Install C-clip (8) onto support where it exits the backside of machine motor mount to hold support in place.
- Install right side motor mount assembly in place of stock motor mount using washers and nuts saved from step 3, and bolts (22 and 23) from kit. Tighten bolts to 25-30 ft-lbs (41-47 Nm).
- Install brake pedal assembly (18) into master cylinder by turning push rod at flats to thread on rod end. Adjust rod length with jam nut (6) until brake pedal has reached a 45 degree angle.
- Put Loctite 243 on threads of clevis mounting screw (4) and install clevis (17), and footrest (stock), as shown. To install footrest, place a spring washer (19), along with the mount end of the footpeg, inside the slots of the clevis. Make sure the spring washer is positioned inside the clevis with the square edge towards the inside as shown in Figure 3. Secure footpeg and spring washer with bolt (2) and locknut (7). Tighten locknuts to 19 ft-lbs (26 Nm).
- Reinstall exhaust system according to Service Manual procedures.



**Figure 2. Brake Side Footrest Mounting (original equipment)**

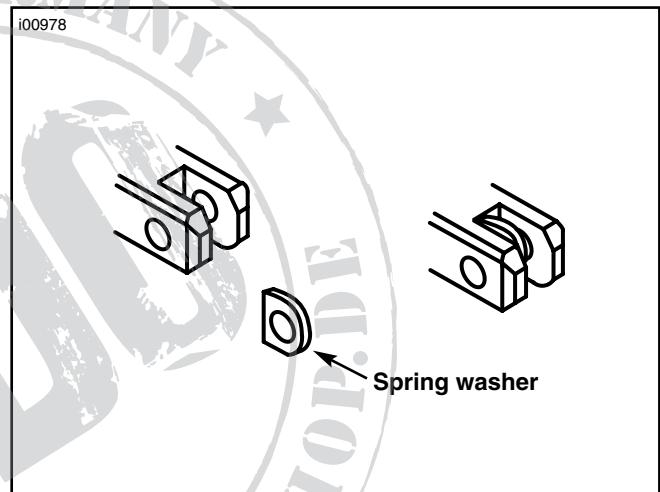

**Figure 3. Footrest**



**Figure 4. Make Sure Shifter Rod is Positioned as Shown**



# Service Parts

Part No. 33891-98 & others | Date 9/03

## Sportster Forward Foot Controls

101239

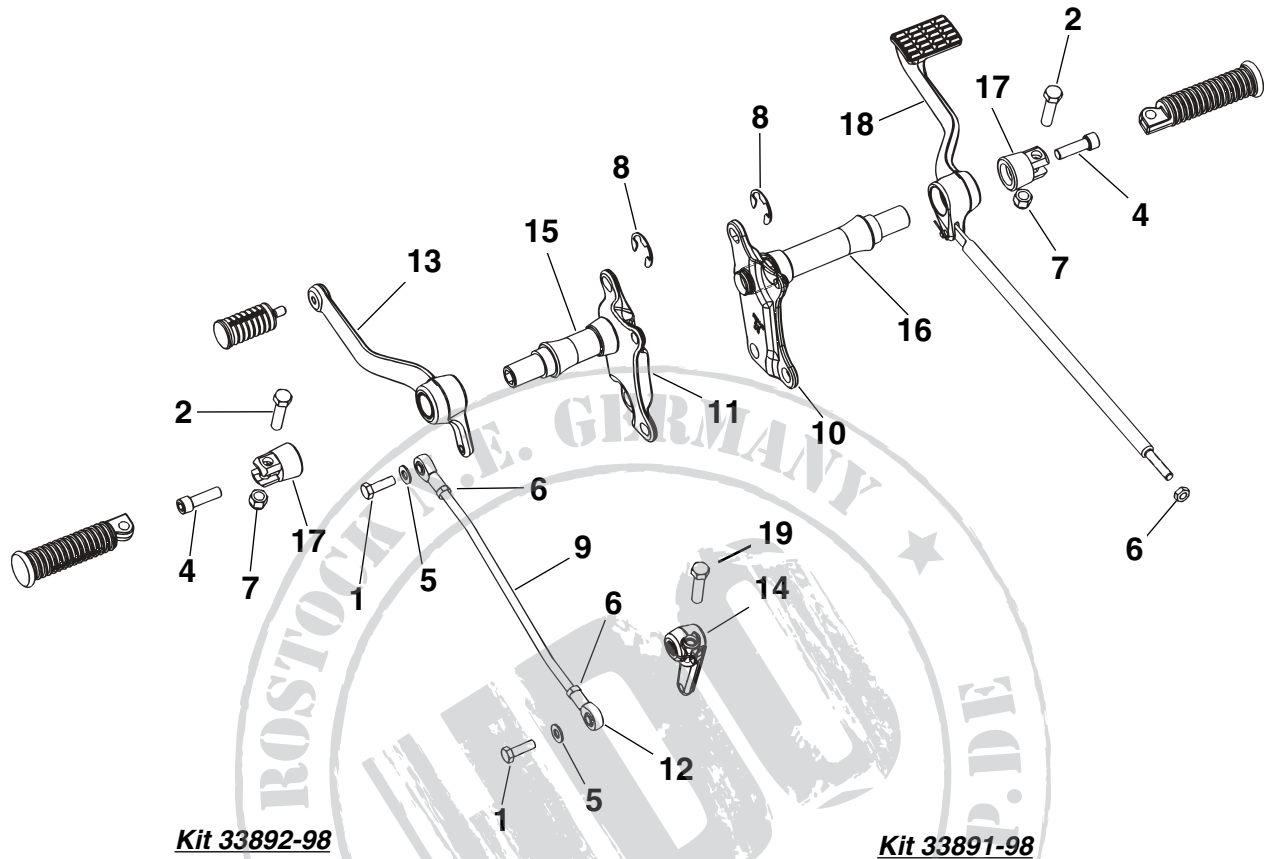

**Kit 33892-98**

**Kit 33891-98**

Item	Description	Part Number	Item	Description	Part Number
1	Bolt (2)	4017	1	Bolt (2)	94194-91T
2	Bolt (2)	4721	2	Bolt (2)	94236-91T
3	Hexsocket capscrew (not shown)	3549A	3	Hexsocket capscrew (not shown)	3549A
4	Screws (2)	4748	4	Screws (2)	4748
5	Washers (4)	6016	5	Washers (4)	6016
6	Hex jam nuts (3)	7744	6	Hex jam nuts (3)	94043-90T
7	Locknuts (2)	7778	7	Locknuts (2)	7778
8	C-clips (2)	11302	8	C-clips (2)	11302
9	Rod shifter	11763	9	Rod shifter	11764
10	Machine motor mount, RH	16294-99	10	Machine motor mount, RH	16323-98
11	Machine motor mount, LH	16297-99	11	Machine motor mount, LH	16324-98
12	Tie rod ends (2)	33871-85B	12	Tie rod ends (2)	33871-85B
13	Shift lever pedal	49303-98	13	Shift lever pedal	49302-98
14	Shift lever (transmission)	34670-04	14	Shift lever (transmission), chrome	34670-04
15	Foot control support, LH	42420-99	15	Foot control support, LH	42589-98
16	Foot control support, RH	42421-99	16	Foot control support, RH	42590-98
17	Foot rest clevis (2)	42426-99	17	Foot rest clevis (2)	42591-98
18	Brake pedal	49301-98	18	Brake pedal	49300-98
19	Screw	2708A	19	Screw	2708A
20	Spring washers (2), (not shown)	50912-72	20	Spring washers (2), (not shown)	50912-72
22	Loctite 243 (2), (not shown)	94635-98	21	Loctite 243 (2), (not shown)	94635-98
22	Sockethead capscrews (2) (not shown)	897	22	Sockethead capscrews (2) (not shown)	897
23	Bolts (4), 3/8-24 x 1-1/4 in. long (not shown)	4337W	23	Bolts (4), 3/8-24 x 1-1/4 in. long (not shown)	4337W
24	Bolts (2), 3/8-24 x 5-1/2 in. long (not shown)	4413	24	Bolts (2), 3/8-24 x 5-1/2 in. long (not shown)	4413